

SnackMiser™

SM170 / SM171 EZ Installation Instructions

SnackMiser™ is designed to operate as an intelligent power controller for non-refrigerated vending machines. Note that the SnackMiser may not be used on any vending machine which contains refrigerated products.

General Theory of Operation

Using a Passive Infrared (PIR) occupancy sensor, SnackMiser will automatically shut down the controlled non-refrigerated vending machine when the area around the machine has been vacant for 15 minutes (factory default) or whatever time the unit is set for by the Timeout Switches.

To install the SnackMiser, follow these simple steps:

Prepare For Installation

1. Unplug the snack machine from the wall outlet. If it is necessary to move the machine, be careful as it can be heavy.
2. Remove ALL items from top of the snack machine. Using a clean cloth, carefully wipe the area as shown where the SnackMiser will be attached. Ensure the area is dry when cleaning is complete. The surface temperature of the back of the vending machine should be above 65F to ensure the Velcro adhesive adheres properly to the machine.

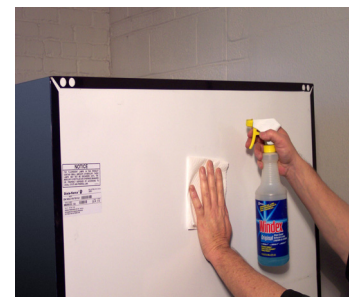

Install The SnackMiser

3. The SnackMiser will be placed on top of rear of the snack machine as shown below for each model. Carefully remove the white plastic material covering the adhesive backing on the Velcro. Be very careful not to contact the exposed Velcro adhesive prematurely to the machine back, as it is very difficult to remove. First place the SnackMiser on top of the snack machine without the Velcro adhesive touching the machine back, then slide the SnackMiser forward so the adhesive touches the rear of the machine in your intended placement location. Press firmly to ensure good contact.

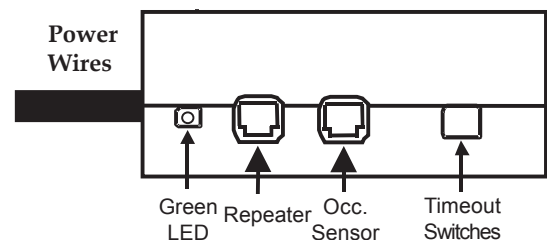

SnackMiser™

SM170 / SM171 EZ Installation Instructions (cont'd.)

4. If a Secondary SnackMiser is being installed, use the supplied 3 Meter (10 feet) phone style cable to connect the OCCUPANCY SENSOR connector on this SnackMiser to the REPEATER connector on the Primary SnackMiser. Only remove the yellow label covering the REPEATER connector on the previous unit in the chain. Additional Secondary SnackMisers can be daisy-chained using the same techniques shown in the diagram below. A maximum of four Misers can be daisy-chained in this fashion. It is acceptable to mix SnackMisers with VendingMisers, PlugMisers, and/or CoolerMisers provided the sensor coverage is acceptable for all devices sharing the sensor.

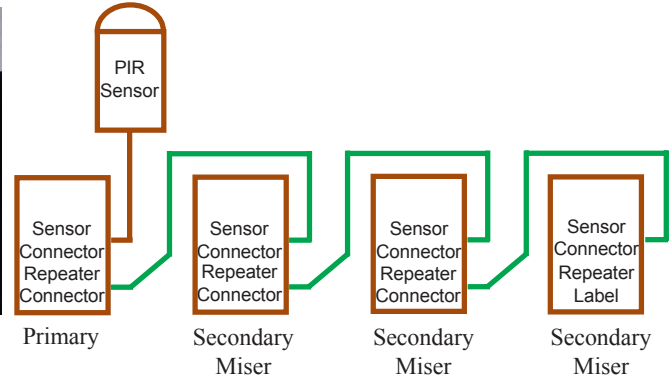

Validate The Installation

5. Plug the snack machine's power cord into the SnackMiser. Then, plug each SnackMiser's power cord into the wall outlet. The following should occur:
- The vending machine should power up immediately.
 - The Green LED should flash twice to indicate that the SnackMiser is functional.
 - The Green LED will be on solid to indicate occupancy is detected.
 - The Green LED will indicate no occupancy by flashing off every few seconds.

Switch Settings
↑↑↑ = 3 Seconds
↑↑↓ = 2 Hours
↑↓↑ = 3 Hours
↑↓↓ = 1 Hour
↓↑↑ = 25 Minutes*
↓↓↑ = 15 Minutes*
↓↓↓ = 25 Minutes
↓↓↓ = 15 Minutes

Verify correct operation of the occupancy sensor by confirming that the Green light behind the sensor lens comes on after power up. The sensor must be allowed to warm up and stabilize for several minutes before its placement can be verified. During this warm-up period, the sensor may go dark – this is normal behavior. Once the sensor is warmed up, it will flash Green at the slightest movement within its field of view. Validate that the sensor can "See" the occupant in all desired areas around the snack machine. If necessary, relocate the sensor and repeat the coverage test.

First Timeout after power up is 30 seconds except *

6. As a final functional test, the SnackMiser will power-down the first time only after installation approximately thirty seconds after the area around the machine is vacant. Covering the occupancy sensor will allow validation of the power-down operation if so desired. Following this initial power-down, the SnackMiser will operate with its standard 15 minute time-out or as set by the timeout switches, and will immediately turn the power on when occupancy is detected.

As noted above in the Switch Settings table, all but two of the time-out selections will power off 30 seconds after initial power-up to enable complete testing of the installed SnackMiser. All subsequent time-outs will be according to the Timeout Switch selection

