



CM2iQ™ Energy Management System

Installation and Service Instructions

This guide provides you with the information needed to install a CM2iQ into a refrigerated beverage cooler. Note: This product is intended for use ONLY in non-perishable beverage coolers with maximum compressor size of one (1) horsepower and evaporator fans with a maximum three (3) Amp load. The CM2iQ is to be installed into the same machine compartment as the existing cold control.

Theory of Operation

The CM2iQ is an energy management system installed as a replacement for the existing cold control to intelligently control and optimize the cooling system of a refrigerated beverage cooler (non-perishable items). The CM2iQ operates in four modes (*Initial Power-On, Normal, Energy Savings and Recovery*) to control the cooling system within the machine for maximum energy savings. The CM2iQ monitors the cold box air temperature using an electronic temperature probe and uses its internal timers to track compressor run times and monitors for door open detection. The CM2iQ is capable of individually controlling compressor and evaporator fan cycles to reduce cooler energy consumption and maintain product temperatures while also performing fault diagnostics to ensure cooler reliability and reduce maintenance calls.

Cooling system faults such as evaporator coil freeze-ups due to a door left open or too low of a cold setting, high head pressure compressor starts due to instantaneous compressor starting at power-up and compressor system / evaporator fan system failures are detected and in most cases resolved by the CM2iQ system. Protection circuitry in the CM2iQ prevents the compressor operation in either high or low AC voltage conditions to ensure the compressor motor is not damaged by this condition. The CM2iQ system provides energy savings, better control of product temperatures, fault detection and resolution capabilities far beyond those of the traditional cold controls typically installed in refrigerated beverage coolers.

CM2iQ Red LED States

- Flashes twice, and then remains on solid at power-up to indicate that the CM2iQ microprocessor and temperature probe have passed their selftests.
- Flashes quickly for several seconds to indicate when a door open event has been detected.
- On solid – normal mode, compressor off, evaporator fan on.
- 90% duty cycle - normal mode, compressor on, door open event detected within last 15 minutes.
- 50% duty cycle - normal mode, compressor on, no door open detected within last 15 minutes.
- 10% duty cycle - energy savings mode, compressor off, evaporator fan off or on.
- LED off – Recovery mode, compressor off, evaporator fan on.

Parts List

- 1 - 50130 CM2iQ System
- 1 - 70300 Installation Kit (Including)
 - 4 - 11811 Wire Nuts
 - 2 - 17300 Nylon Tie Wraps
 - 2 - 17608 6 - 32 x 1/4" machine screws
 - 1 - 17621 Green, Self-Drilling Screw
- 1 - 18100 CM2iQ Control Knob
- 1 - 60312 CM2iQ Harness Assembly

Tools Required

- #2 Phillips Head Screwdriver
- Electric Drill w/ Phillips head bit
- Nut Drivers as needed for access

CM2iQ Controller

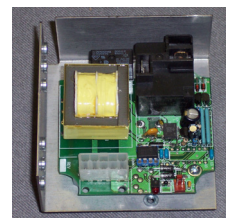

50130

Install Kit

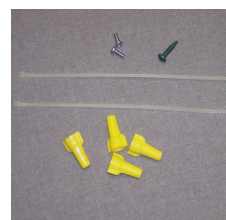

70300

CM2iQ Harness

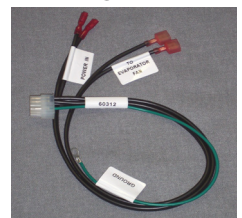

60312

Control Knob



18100

Scope of Use

The CM2iQ is acceptable for use in beverage coolers which use either mechanical or electronic cold controls. Installation should not be attempted if it is necessary to cut any of the existing wiring. The following is a list of acceptable models of machines for field installation of the CM2iQ.

Beverage-Air - MT12, MM14, MT14, MT15, MT17, MT19, MT22, MT23, MT27, MT33, MT35, MT38, MT45, MT48, MT49, and MT66 cabinets

Habco Beverage Systems - ESM10, ESM12, ESM28, ESM42, ESM46, SE20, SE28, SE40, and SE42 cabinets

True Manufacturing - GDM10, GDM12, GDM15, GDM19, GDM23, GDM26, GDM33, GDM35, GDM37, GDM41, GDM43, GDM45, GDM47, GDM49, GDM69, and GDM72 cabinets

QBD Cooling Systems - DC22, DC26, DC30, DC40, DC45, DC47, DC49, and DC60 cabinets

Installation

Please follow these instructions carefully to insure proper operation of the CM2iQ. Note: This product is intended for use ONLY in UL listed self-contained non-perishable beverage coolers with maximum compressor size of one (1) horsepower and evaporator fans with a maximum three (3) Amp load. The CM2iQ is to be installed into the same machine compartment as the existing cold control. In addition the existing electronic or mechanical cold control connections must not reside within the cooler door.

Note: These instructions are intended only for qualified service personnel. Improper installation may result in damage to the machine and/or injury to service personnel. Consult the machine service manual and schematics as necessary for machine component locations and wiring information.

1. Unplug the cooler power from the wall outlet. NEVER attempt to service the cooler while power is applied to it.
2. Open the door to the machine and gain access to the cold control wiring.
3. Using the supplied self drilling ground screw connect the CM2iQ wire harness (60312) green wire to the side/rear wiring compartment wall inside the cooler. Ensure the screw is drilled into an area free of raceways and wire routing to prevent damage to existing wiring.
4. Disconnect the compressor load wire pair from the existing mechanical or electronic cold control and reconnect the wire pair to the CM2iQ relay. Completely remove the existing cold control from the cooler.

***Note:** If any wire connection cannot be made with the existing connectors, utilize the supplied wire nuts to make the wire connection. Installation of the CM2iQ is not recommended for machines where it is necessary to cut any wiring in the existing wire harnesses. Use existing machine wire routing paths when routing any wires. Avoid wire routing near moving parts or sharp edges.*

CAUTION! *Ensure the ribbed wires are connected together on all wire pairs to maintain the polarity of the hot and neutral wires!*

5. Locate the evaporator fan power connections, either on the fan or its wiring harness and disconnect the power in wires. Connect the CM2iQ wire harness “To Evaporator Fan” pair to the fan or its harness. Ensure ribbed (neutral) wires are connected together to maintain polarity.
6. Connect the evaporator fan power wire pair disconnected in step 5 to the CM2iQ wire harness “Power In” pair. Ensure ribbed (neutral) wires are connected together to maintain polarity.
7. Connect and lock the CM2iQ wire harness to the CM2iQ controller.
8. Mount the CM2iQ controller (50130) using supplied machine screws (17608) in the location previously used by the cold control removed in step 4, ensuring the potentiometer is accessible for user adjustment. Push the supplied control knob (18100) onto the shaft of the potentiometer on the CM2iQ controller. Adjust the control knob to the center detente position and check to verify that the indicating arrow on the machine is pointing to the number 5 on the CM2iQ control knob. Remount the CM2iQ controller assembly if necessary to achieve the desired alignment.

CAUTION! Ensure that all wiring is clear of any moving parts and sharp edges before applying power to the cooler.

9. While CM2iQ is accessible, apply power to the cooler and test the items below:
 - Ensure the CM2iQ LED blinks twice and then stays ON solid to indicate the CM2iQ microcontroller and temperature sensor have passed their self tests.
 - Ensure the evaporator fans start immediately after the CM2iQ self test is completed when the cooler power is applied.
 - Open the cooler door to ensure that cooling will be needed and wait three minutes. Ensure the compressor turns ON after this time period.
 - Ensure any cooler switches and lights operate normally.
 - If all the above tests are passed, proceed to step 10, otherwise follow the Troubleshooting Guide at the end of this manual to correct any problems.
10. Disconnect the cooler from the power outlet.
 - Secure wiring using the supplied cable ties and close access to wiring. Ensure all wiring is secured clear of moving parts and sharp edges.
 - Adjust the CM2iQ control knob to the center detente position (5) as an initial cold control setting. Closely monitor the product temperature for the first 72 hours of operation, and make adjustments as need to maintain the desired product temperature.
 - Close the door to the cooler and reconnect cooler power.

The cooler will operate normally for the first 12 hours of operation. After this initial 12 hour cool down period, the cooler will enter energy savings mode if no door open events have been detected for more than 15 minutes and the compressor is not on. While in energy savings mode the evaporator fan may be either off or on depending on the air temperature in the cold box. The CM2iQ will not enter energy savings mode if the cooler has been recently reloaded. Protection circuitry in the CM2iQ prevents the compressor operation in either high or low AC voltage conditions to ensure the compressor motor is not damaged by this condition. To prevent high head pressure starts the compressor operation is delayed for three minutes after the CM2iQ is powered on, and for a period of three minutes after the compressor was last turned off.

Wiring Diagram (After Installation)

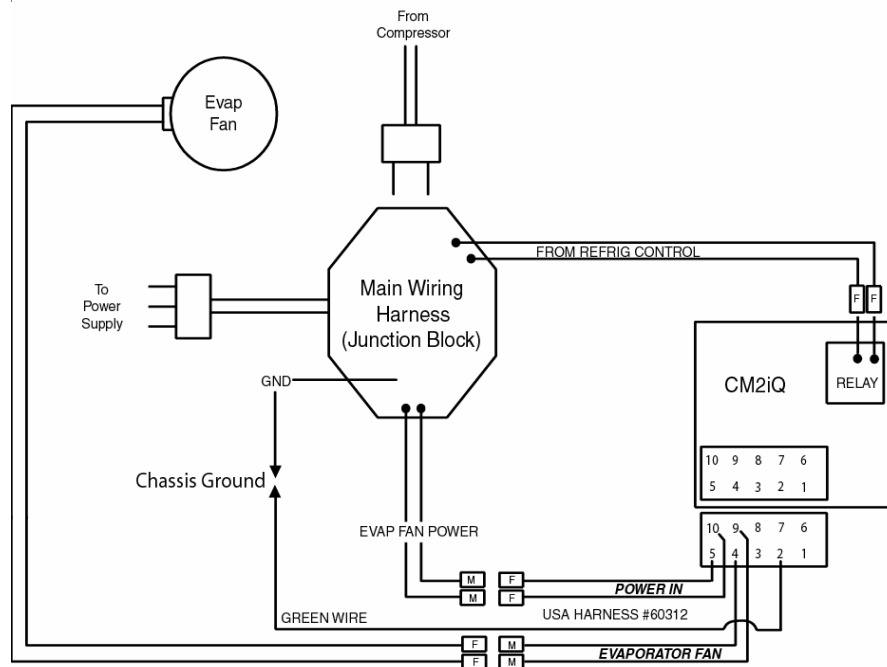

Troubleshooting Guide

Ensure all installation steps have been performed correctly and the coolers main power cord is disconnected before proceeding with any of the Corrective Actions described in this CM2iQ system troubleshooting guide.

Symptom	Possible Root Cause	Corrective Action
CM2iQ LED does not turn ON at all when machine is initially powered ON.	<ol style="list-style-type: none"> Cooler is not plugged into the wall outlet. CM2iQ wire harness not plugged into CM2iQ. CM2iQ "Power in" and "Evaporator fan" wires reversed. 	<ol style="list-style-type: none"> Plug the cooler into the wall outlet. Plug the CM2iQ wiring harness into the CM2iQ. Reverse the wires to ensure the "Power in" wires connect to the AC line and the "Evaporator fan" wires connect to the fan.
Compressor and Evaporator fan both turn on for three seconds then turn off immediately after initial power ON.	<ol style="list-style-type: none"> Test jumper installed on "Conn4" on CM2iQ Controller. This will force the CM2iQ into its self test mode of operation. Defective CM2iQ controller. 	<ol style="list-style-type: none"> Remove the test jumper from "Conn4" located to the right of the LED on the CM2iQ. Ensure that there is no dirt or lint between the pins of the connector. Replace the CM2iQ controller.
CM2iQ LED does not blink twice then turn ON solid when machine is initially powered ON. The CM2iQ has failed its self-test.	<ol style="list-style-type: none"> Cabinet temperature conditions are not between 20F and 105F. Defective CM2iQ controller 	<ol style="list-style-type: none"> CM2iQ selftest of temperature sensor fails if the cabinet temperature is not between 20 and 105F. Retest when met. Replace the CM2iQ controller.
Evaporator fans do not start immediately after the LED blinks twice when machine is powered ON.	<ol style="list-style-type: none"> CM2iQ harness "Evaporator fan" wires not connected to the fan(s). Evaporator fan(s) is(are) not operational. Defective CM2iQ Controller 	<ol style="list-style-type: none"> Connect CM2iQ harness "Evaporator fan" wires to the evaporator fan. Ensure evaporator fan wire integrity and replace evaporator fan as necessary. Replace the CM2iQ controller.
Compressor doesn't start when Machine is powered ON for more than 3 minutes and cooling would reasonably be needed.	<ol style="list-style-type: none"> Compressor control wires not wired correctly. Defective CM2iQ controller. 	<ol style="list-style-type: none"> Connect compressor wire pair to CM2iQ relay connections. Replace the CM2iQ controller.
Compressor starts immediately with initial power ON and runs continuously.	<ol style="list-style-type: none"> Compressor wires installed incorrectly or not connected to the CM2iQ relay. Defective CM2iQ controller. 	<ol style="list-style-type: none"> Check wiring of the compressor connections to the CM2iQ. Replace the CM2iQ controller.

CM2iQ Technical Specifications

Input Voltage/Frequency:	115VAC / 60 Hz
Maximum Load:	12 Amps(Steady-State)
Power Consumption:	Less than 1 Watt(Standby)
Operating Temperature:	-15 C to 50 C
Storage Temperature:	-40 C to 85 C
Relative Humidity:	95% maximum(Non-condensing)
Safety:	UL/CN classified, Category SOSR7, File #SA13135 UL/C-UL recognized - XAPX2, XAPX8 standard, File #E243565
Compatibility:	Any UL listed self-contained non-perishable beverage coolers with maximum (1) horsepower compressor size and maximum (3) Amp evaporator fans load and having existing cold control connections not residing in the vendor door.