



- Read and experiment with each step
- To perform multiple fan tests*, refer to:
 - Manual-Blower Door-Multiple Fan Operation 5000 6000
 - FanTestic Software Manual
 - DM32 Operator's Manual

*Tests for CGSB 149, LEED, ASTM E778, EN13829, and ATTMA TS-1 may require more elaborate steps and training. This guide is intended only for familiarization with the controls.

Step 1: Prepare the building

- 1.1 Close the outside doors and windows.
- 1.2 Open all interior doors leading to conditioned spaces.
- 1.3 Shut off HVAC, exhaust fans, dryers, A/C, and furnaces.
- 1.4 Turn gas hot waters to pilot.



Step 2: Setup the DM32s

- 2.1 Setup the DM32s as needed for the required testing standards.
- 2.2 Ensure that rechargeable batteries are fully charged or that spare batteries are available for each gauge.

Step 3: Unpack the Stacking Panels

- 3.1 Remove however many panels will be used for the test.



Step 4: Build a frame

- 4.1 Prepare a frame out of dimensional lumber to hold the stacking panels.
- 4.2 Use the Stacking Panels to guide the build design.

Step 5: Secure Panels

- 5.1 Screw the Stacking Panels into the frame.



Step 6: Secure frame to the building opening

- 6.1 Tightly secure the frame to the building opening. The frame must be stable & reinforced to ensure the structure can maintain force of the fans.



Step 7: Install the fans

- 7.1 Insert all fans into the Stacking Panels.



QG314



7.2 Fasten the metal hook to the Stacking Panel, then wrap the Velcro strap around the fan handle.



Step 8: Seal any remaining gaps

8.1 Excess holes/gaps may exist depending on size of the building opening. Seal all remaining openings.

In the photo below, 9 fans were used and plywood was used to seal the remaining space.



Step 9: Connect the fan umbilical

9.1 Connect each fan to one of the variable speed drives with the umbilical that is attached to the drive.

9.2 Connect the grey Output cable from the drive to the input port on the fan top.

9.3 Connect the yellow pressure tube to the two ports on the fan top.

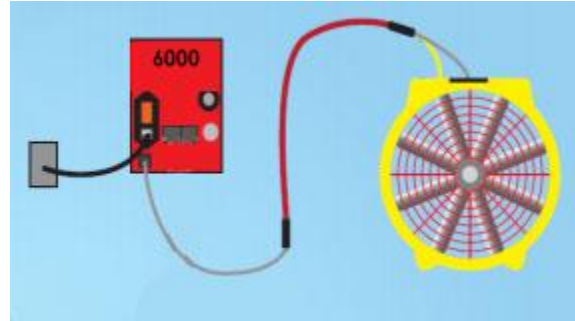

Step 10: Connect all DM32s

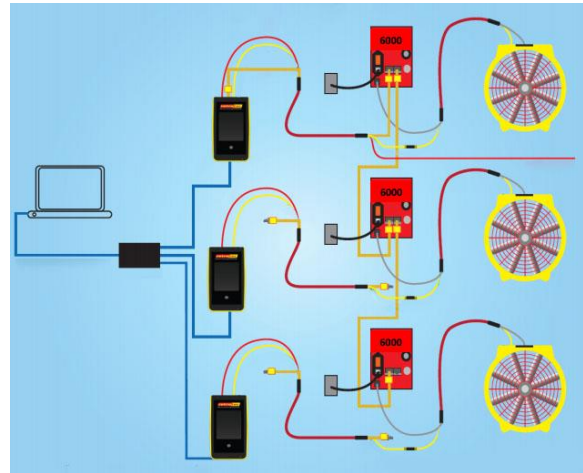

Step 11: Commence testing

You are now ready to commence testing. For detailed testing instructions, see:



QG314