

Cylindrical Cable Outgoing Connector Type

Cylindrical cable outgoing connector type proximity sensor

■ Features

- Shorten the time of maintenance with the body
- Improved the noise resistance by adopting dedicated IC (DC 3-wire type)
- Reverse power polarity (DC 3-wire), surge, overcurrent protection (DC type)
- Red LED status indication
- IP67 rated waterproof structure (IEC standard)
- Replacer for micro switches and limit switches



⚠ Please read "Caution for your safety" in operation manual before using.



■ Specifications

● DC 2-wire type

Model	PRWT08-1.5DO PRWT08-1.5DC	PRWT08-2DO PRWT08-2DC	PRWT12-2DO PRWT12-2DC	PRWT12-4DO PRWT12-4DC	PRWT18-5DO PRWT18-5DC	PRWT18-8DO PRWT18-8DC	PRWT30-10DO PRWT30-10DC	PRWT30-15DO PRWT30-15DC
Sensing distance	1.5mm ±10%	2mm ±10%		4mm ±10%	5mm ±10%	8mm ±10%	10mm ±10%	15mm ±10%
Hysteresis	Max. 10% of sensing distance							
Standard sensing target	8×8×1mm (Iron)		12×12×1mm (Iron)		18×18×1mm (Iron)	25×25×1mm (Iron)	30×30×1mm (Iron)	45×45×1mm (Iron)
Setting distance	0 ~ 1.05mm	0 ~ 1.4mm		0 ~ 2.8mm	0 ~ 3.5mm	0 ~ 5.6mm	0 ~ 7mm	0 ~ 10.5mm
Power supply (Operation voltage)	24VDC (15~30VDC)							
Leakage current	Max. 0.6mA							
Response frequency(★1)	1.5kHz	1kHz	1.5kHz	500Hz		350Hz	400Hz	200Hz
Residual voltage	Max. 4V							
Affection by Temp.	±10% Max. for sensing distance at +20℃ within temperature range of -25 ~ +70℃							
Control output	2 ~ 100mA							
Insulation resistance	Min. 50MΩ (at 500VDC mega)							
Dielectric strength	1500VAC 50/60Hz for 1 minute							
Vibration	1mm amplitude at frequency of 10 ~ 55Hz in each of X, Y, Z directions for 2 hours							
Shock	500m/s ² (50G) in X, Y, Z directions for 3 times							
Indicator	Operation indicator (Red LED)							
Ambient temperature	-25 ~ +70℃ (at non-freezing status)							
Storage temperature	-30 ~ +80℃ (at non-freezing status)							
Ambient humidity	35 ~ 95%RH							
Protection circuit	Surge, Overcurrent protection circuit							
Protection	IP67 (IEC standard)							
Approval	CE							
Unit weight	Approx. 30g		Approx. 45g		Approx. 65g		Approx. 169g	

★(★1) The response frequency is the average value. The standard sensing target is used and the width is set as 2 times of the standard sensing target, 1/2 of the sensing distance for the distance.

*Please fasten the vibration part with Teflon type.

*See J-48 for IEC standard connector cables and specifications.

(A) Counter

(B) Timer

(C) Temp. controller

(D) Power controller

(E) Panel meter

(F) Tacho/ Speed/ Pulse meter

(G) Display unit

(H) Sensor controller

(I) Switching power supply

(J) Proximity sensor

(K) Photo electric sensor

(L) Pressure sensor

(M) Rotary encoder

(N) Stepping motor & Driver & Controller

(O) Graphic panel

(P) Production stoppage models & replacement

PRW Series

●Specifications(DC 3-wire type)

Model	PRW08-1.5DN PRW08-1.5DP PRW08-1.5DN2 PRW08-1.5DP2 PRWL08-1.5DN PRWL08-1.5DP PRWL08-1.5DN2 PRWL08-1.5DP2	PRW08-2DN PRW08-2DP PRW08-2DN2 PRW08-2DP2	PRW12-2DN PRW12-2DP PRW12-2DN2 PRW12-2DP2	PRW12-4DN PRW12-4DP PRW12-4DN2 PRW12-4DP2	PRW18-5DN PRW18-5DP PRW18-5DN2 PRW18-5DP2 PRWL18-5DN PRWL18-5DP PRWL18-5DN2 PRWL18-5DP2	PRW18-8DN PRW18-8DP PRW18-8DN2 PRW18-8DP2 PRWL18-8DN PRWL18-8DP PRWL18-8DN2 PRWL18-8DP2	PRW30-10DN PRW30-10DP PRW30-10DN2 PRW30-10DP2 PRWL30-10DN PRWL30-10DP PRWL30-10DN2 PRWL30-10DP2	PRW30-15DN PRW30-15DP PRW30-15DN2 PRW30-15DP2 PRWL30-15DN PRWL30-15DP PRWL30-15DN2 PRWL30-15DP2
Sensing distance	1.5mm ±10%	2mm ±10%	4mm ±10%	5mm ±10%	8mm ±10%	10mm ±10%	15mm ±10%	
Hysteresis	Max. 10% of sensing distance							
Standard sensing target	8×8×1mm (Iron)		12×12×1mm (Iron)		18×18×1mm (Iron)	25×25×1mm (Iron)	30×30×1mm (Iron)	45×45×1mm (Iron)
Setting distance	0 ~ 1.05mm	0 ~ 1.4mm	0 ~ 1.4mm	0 ~ 2.8mm	0 ~ 3.5mm	0 ~ 5.6mm	0 ~ 7mm	0 ~ 10.5mm
Power supply (Operation voltage)	12-24VDC (10-30VDC)							
Current consumption	Max. 10mA							
Response frequency(*1)	1.5kHz	1kHz	1.5kHz	500Hz	350Hz	400Hz	200Hz	
Residual voltage	Max. 1.5V							
Affection by Temp.	±10% Max. for sensing distance at +20°C within temperature range of -25 ~ +70°C							
Control output	200mA							
Insulation resistance	Min. 50MΩ (at 500VDC mega)							
Dielectric strength	1500VAC 50/60Hz for 1minute							
Vibration	1mm amplitude at frequency of 10 ~ 55Hz in each of X, Y, Z directions for 2 hours							
Shock	500m/s ² (50G) in X, Y, Z direction for 3 times							
Indicator	Operation indicator (Red LED)							
Ambient temperature	-25 ~ +70°C (at non-freezing status)							
Storage temperature	-30 ~ +80°C (at non-freezing status)							
Ambient humidity	35 ~ 95%RH							
Protection circuit	Surge, Reverse power polarity, Overcurrent protection circuit							
Protection	IP67 (IEC standard)							
Approval	CE							
Unit weight	PR08:Approx. 68g PRW08:Approx. 30g		Approx. 40g		PRW18:Approx. 84g PRWL18:Approx. 108g		PRW30:Approx. 143g PRWL30:Approx. 178g	

※(*1) The response frequency is the average value. The standard sensing target is used and the width is set as 2 times of the standard sensing target, 1/2 of the sensing distance for the distance.

●Specifications(AC 2-wire type)







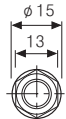
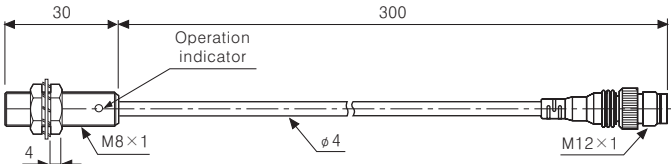

Model	PRW12-2AO PRW12-2AC	PRW12-4AO PRW12-4AC	PRW18-5AO PRW18-5AC PRWL18-5AO PRWL18-5AC	PRW18-8AO PRW18-8AC PRWL18-8AO PRWL18-8AC	PRW30-10AO PRW30-10AC PRWL30-10AO PRWL30-10AC	PRW30-15AO PRW30-15AC PRWL30-15AO PRWL30-15AC
Sensing distance	2mm ±10%	4mm ±10%	5mm ±10%	8mm ±10%	10mm ±10%	15mm ±10%
Hysteresis	Max. 10% of sensing distance					
Standard sensing target	12×12×1mm (Iron)		18×18×1mm (Iron)	25×25×1mm (Iron)	30×30×1mm (Iron)	45×45×1mm (Iron)
Setting distance	0 ~ 1.4mm	0 ~ 2.8mm	0 ~ 3.5mm	0 ~ 5.6mm	0 ~ 7mm	0 ~ 10.5mm
Power supply (Operation voltage)	100-240VAC (85-264VAC)					
Leakage current	Max. 2.5mA					
Response frequency(*1)	20Hz					
Residual voltage	Max. 10V					
Affection by Temp.	±10% Max. for sensing distance at +20°C within temperature range of -25 ~ +70°C					
Control output	5 ~ 150mA			5 ~ 200mA		
Insulation resistance	Min. 50MΩ (at 500VDC mega)					
Dielectric strength	1500VAC 50/60Hz for 1minute					
Vibration	1mm amplitude at frequency of 10 ~ 55Hz in each of X, Y, Z directions for 2 hours					
Shock	500m/s ² (50G) in X, Y, Z direction for 3 times					
Indicator	Operation indicator (Red LED)					
Ambient temperature	-25 ~ +70°C (at non-freezing status)					
Storage temperature	-30 ~ +80°C (at non-freezing status)					
Ambient humidity	35 ~ 95%RH					
Protection circuit	Surge protection circuit					
Protection	IP67 (IEC standard)					
Approval	CE					
Unit weight	Approx. 42g		PRW18 : Approx. 87g PRWL18 : Approx. 112g		PRW30 : Approx. 148g PRWL30 : Approx. 185g	

※(*1) The response frequency is the average value. The standard sensing target is used and the width is set as 2 times of the standard sensing target, 1/2 of the sensing distance for the distance.

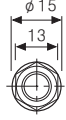
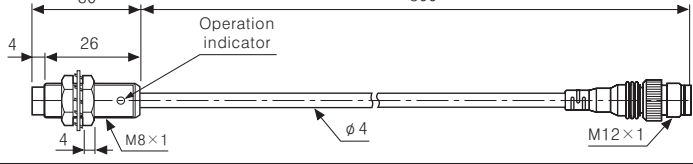
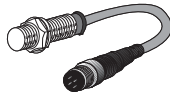
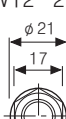
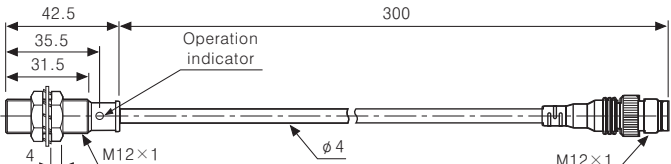
Cylindrical Cable Outgoing Connector Type

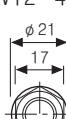
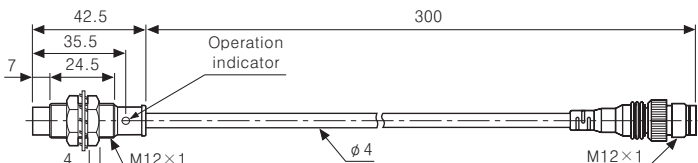
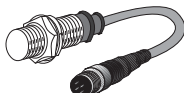
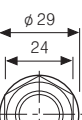
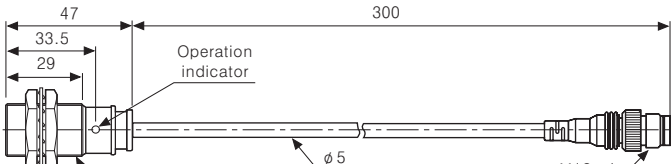
Dimensions

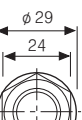
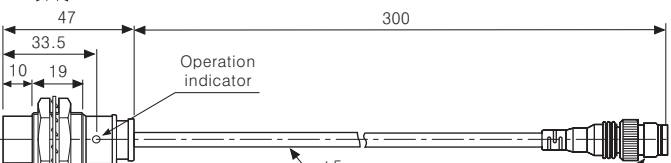
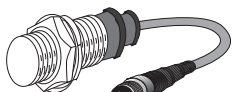
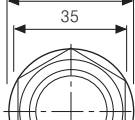
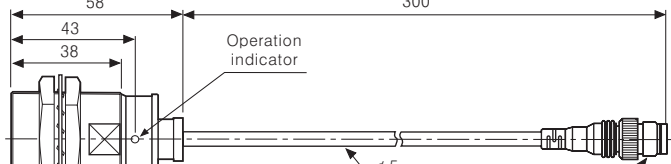
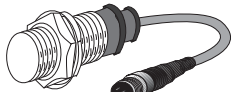
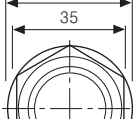
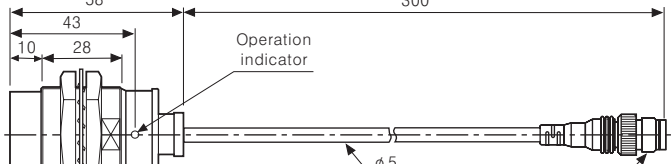
(Unit:mm)

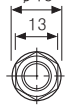
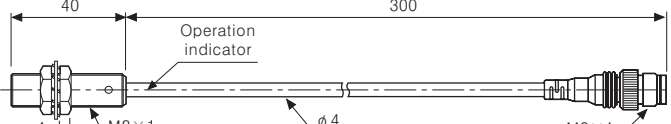
<ul style="list-style-type: none"> ●PRWT08-1.5D□(-I) 	<ul style="list-style-type: none"> ●PRW08-1.5D□ 		(A) Counter
<ul style="list-style-type: none"> ●PRWT08-2D□(-I) 	<ul style="list-style-type: none"> ●PRW08-2D□ 		(B) Timer
<ul style="list-style-type: none"> ●PRWT12-2D□(-I) 	<ul style="list-style-type: none"> ●PRW12-2D□ 		(C) Temp. controller
<ul style="list-style-type: none"> ●PRWT12-4D□(-I) 	<ul style="list-style-type: none"> ●PRW12-4D□ 		(D) Power controller
<ul style="list-style-type: none"> ●PRWT18-5D□(-I) 	<ul style="list-style-type: none"> ●PRW18-5D□ 		(E) Panel meter
<ul style="list-style-type: none"> ●PRWT18-8D□(-I) 	<ul style="list-style-type: none"> ●PRW18-8D□ 		(F) Tacho/ Speed/ Pulse meter
<ul style="list-style-type: none"> ●PRWT30-10D□(-I) 	<ul style="list-style-type: none"> ●PRW30-10D□ 		(G) Display unit
<ul style="list-style-type: none"> ●PRWT30-15D□(-I) 	<ul style="list-style-type: none"> ●PRW30-15D□ 		(H) Sensor controller
<ul style="list-style-type: none"> ●PRWL08-1.5D□ 	<ul style="list-style-type: none"> ●PRW08-1.5D□ 		(I) Switching power supply
			(J) Proximity sensor
			(K) Photo electric sensor
			(L) Pressure sensor
			(M) Rotary encoder
			(N) Stepping motor & Driver & Controller
			(O) Graphic panel
			(P) Production stoppage models & replacement

PRW Series

Dimensions

(Unit:mm)

●PRWL08-2D□

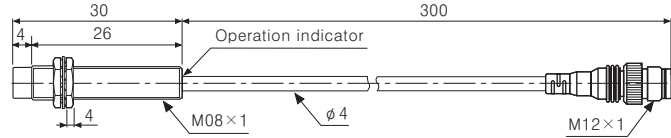
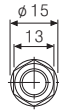
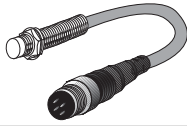

●PRWL18-5D□

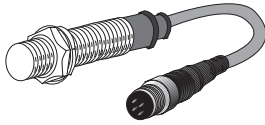

●PRWL18-5A□

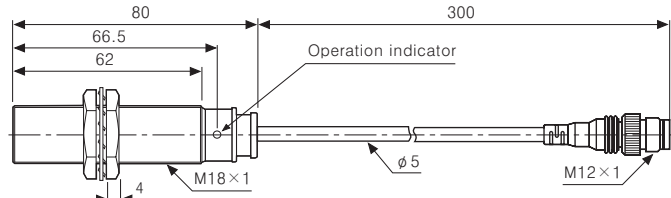
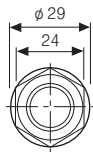

●PRWL18-8D□

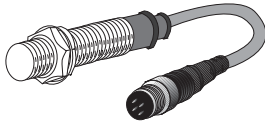

●PRWL18-8A□

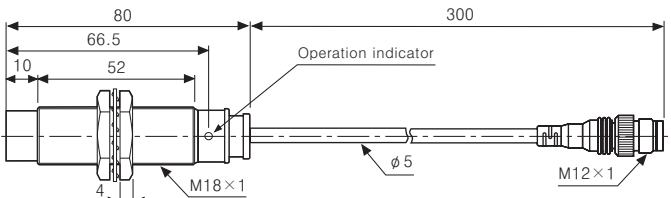
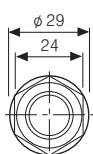

●PRWL30-10D□

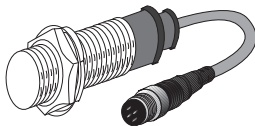

●PRWL30-10A□

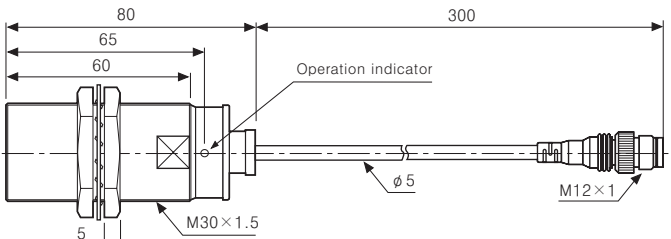
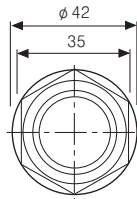

●PRWL30-15D□

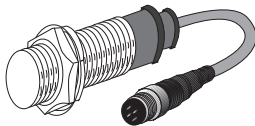

●PRWL30-15A□

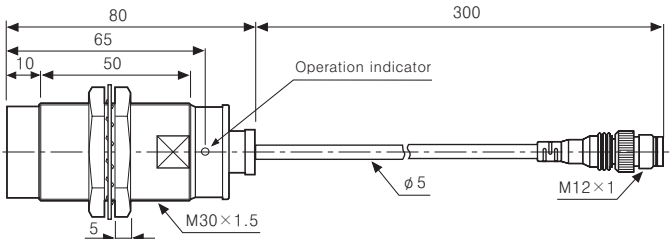
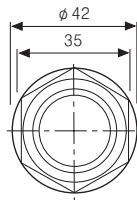

●PRW12-2A□

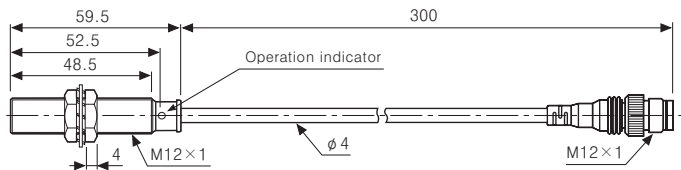
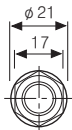

●PRW12-4A□

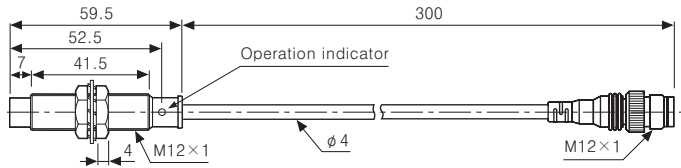
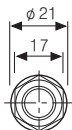

●PRW18-5A□

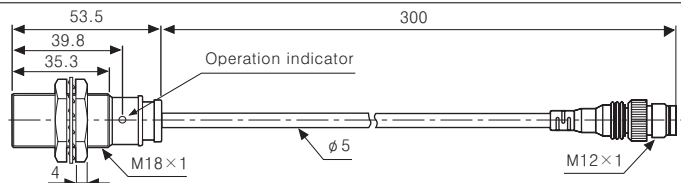
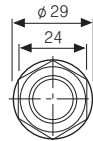

●PRW18-8A□

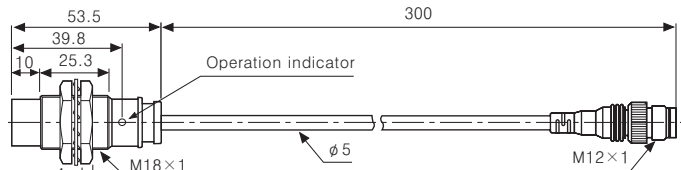

Cylindrical Cable Outgoing Connector Type

Dimensions

● PRW30-10A□

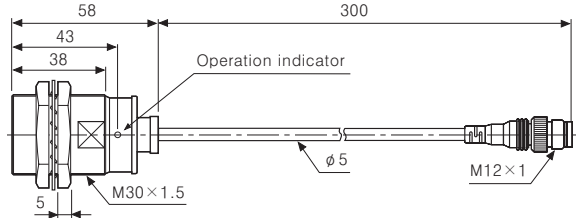
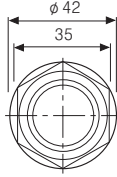
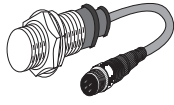

● PRW30-15A□

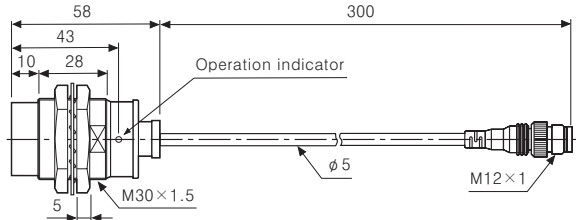
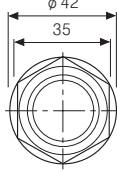
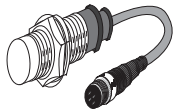

(Unit:mm)

(A) Counter

(B) Timer

(C) Temp. controller

(D) Power controller

(E) Panel meter

(F) Tacho/ Speed/ Pulse meter

(G) Display unit

(H) Sensor controller

(I) Switching power supply

(J) Proximity sensor

(K) Photo electric sensor

(L) Pressure sensor

(M) Rotary encoder

(N) Stepping motor & Driver & Controller

(O) Graphic panel

(P) Production stoppage models & replacement

Control output diagram

DC 2-wire type

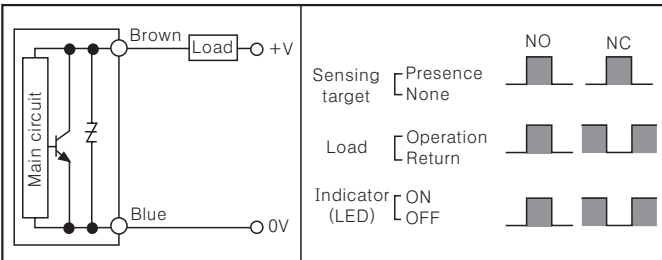

DC 3-wire type

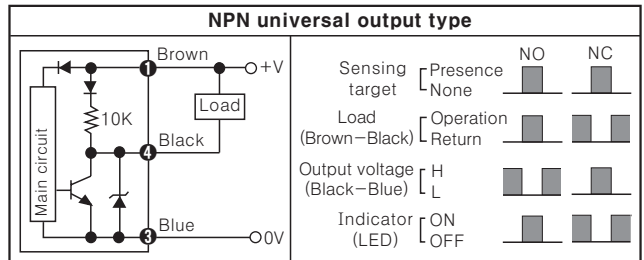

AC 2-wire type

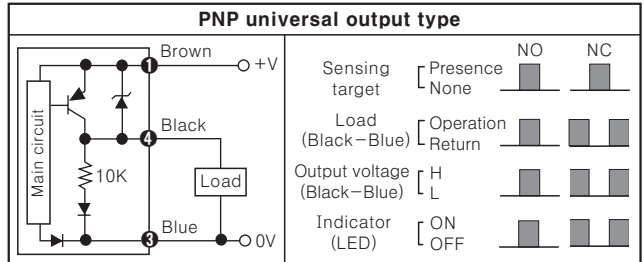
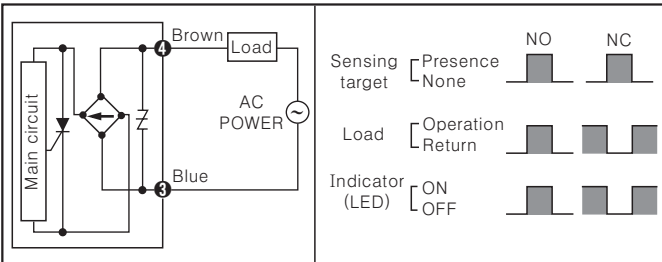

*The number in a circle is pin no. of connector.

Wiring diagram

DC 2-wire type(Standard/non-polar type)

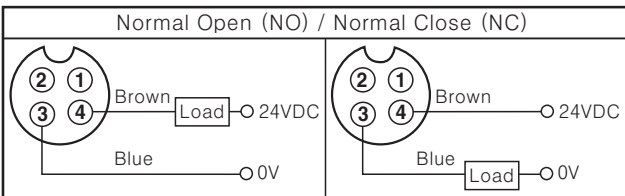

*Pin ① and ② are not connected.
*When using DC 3-wire type of connector cable, black (24VDC) and blue (0V) cables can be used.

DC 2-wire type(IEC standard/IEC standard non-polar type)

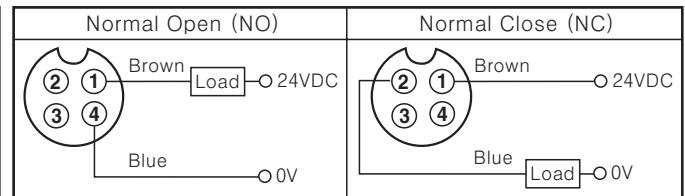

*The type, pin arrangement of connector based upon IEC standard is being developed.
*Please put "I" behind of standard type for purchasing IEC standard product. Ex) PRWT12-4DO-I
*Please put "I" behind of model name for selecting proximity sensor by IEC standard. Ex) CID2-2-I, CLD2-2-I

DC 3-wire type

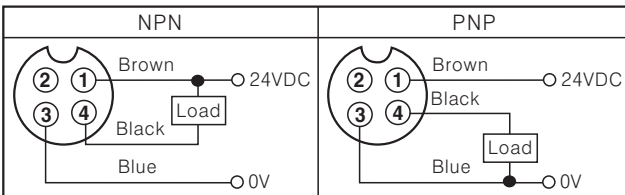

*Please fasten the cleat of connector not to shown the thread. (0.39~0.49N·m)

AC 2-wire type

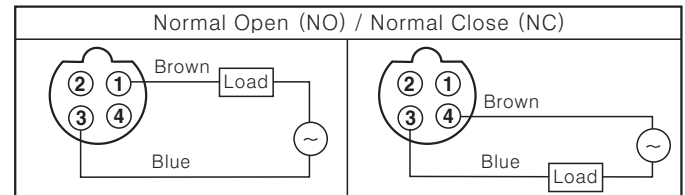

*In case of AC switching type, ② and ③, ① and ④ are connected to each other inside.

PRW Series

Proper usage

Load connections

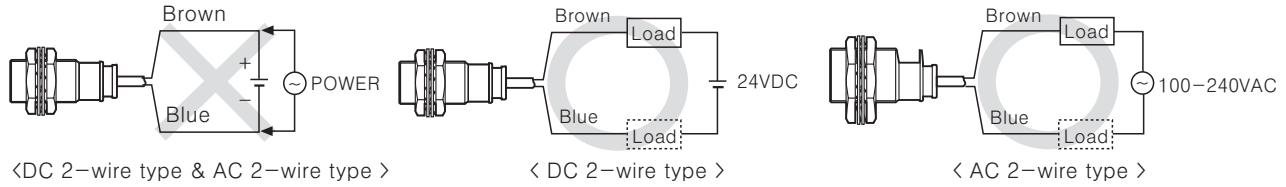

When using DC or AC 2-wire type proximity sensor, the load must be connected otherwise internal components may be damaged. And the load can be connected to either wire.

In case of the load current is small

AC 2-wire type

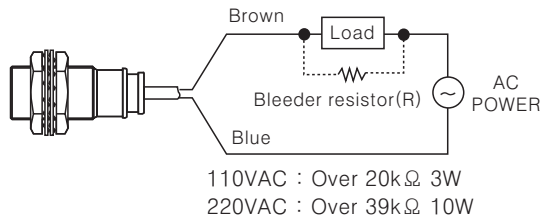

It may cause return failure of load by residual voltage. If the load current is under 5mA, please make sure the residual voltage is less than the return voltage of the load by connecting a bleeder resistor in parallel with the load as shown in the diagram.

$$R = \frac{V_s}{I} \quad (\Omega) \quad P = \frac{V_s^2}{R} \quad (W)$$

[I: Action current of load, R: Bleeder resistance, P: Permissible power]

DC 2-wire type

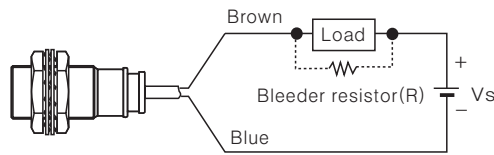

Please make the current on proximity sensor smaller than the return current of load by connecting a bleeder resistor in parallel.

※ W value of Bleeder resistor should be bigger for proper heat dissipation.

$$R = \frac{V_s}{I_o - I_{off}} \quad (\Omega) \quad P = \frac{V_s^2}{R} \quad (W)$$

[Vs : Power supply, Io : Min. action current of proximity sensor
Ioff : Return current of load, P : Number of Bleeder resistance watt]

Mutual-interference & Influence by surrounding metals

When several proximity sensors are mounted closely, malfunction of sensor may be caused due to mutual interference. Therefore, be sure to provide a minimum distance between the two sensors, as below charts.

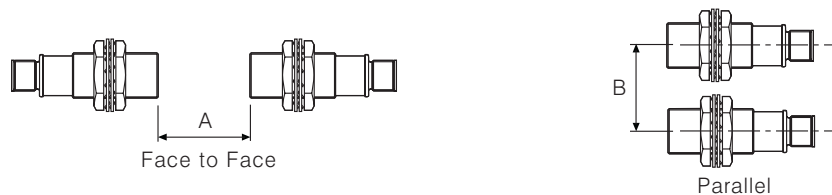

When sensors are mounted on metallic panel, it must be prevented sensors from being affected by any metallic object except target. Therefore, be sure to provide a minimum distance as below chart.

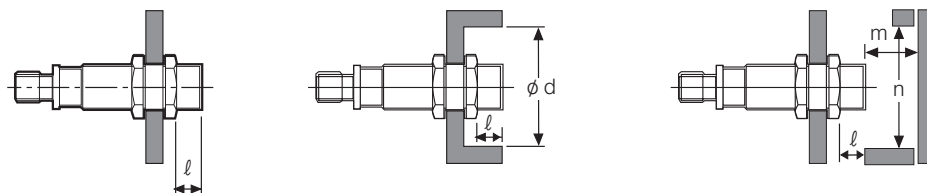

(Unit:mm)

Model	PRW08-1.5D□	PRW08-2D□	PRWT12-2D□	PRWT12-4D□	PRWT18-5D□	PRWT18-8D□	PRWT30-10D□	PRWT30-15D□
Item	PRWT08-1.5D□	PRWT08-2D□	PRW12-2A□	PRW12-4A□	PRW(L)18-5D□	PRW(L)18-8D□	PRW(L)30-10D□	PRW(L)30-15D□
	PRWL08-1.5D□	PRWL08-2D□			PRW(L)18-5A□	PRW(L)18-8A□	PRW(L)30-10A□	PRW(L)30-15A□
A	9	12	12	24	30	48	60	90
B	16	24	24	36	36	54	60	90
l	0	8	0	11	0	14	0	15
φ d	8	24	12	36	18	54	30	90
m	4.5	6	6	12	15	24	30	54
n	12	24	18	36	27	54	45	90