

# PUMP CONTROLLER

One or Two Pump Control with Built-In Alternation, Over Temperature Protection and Seal Failure Monitoring

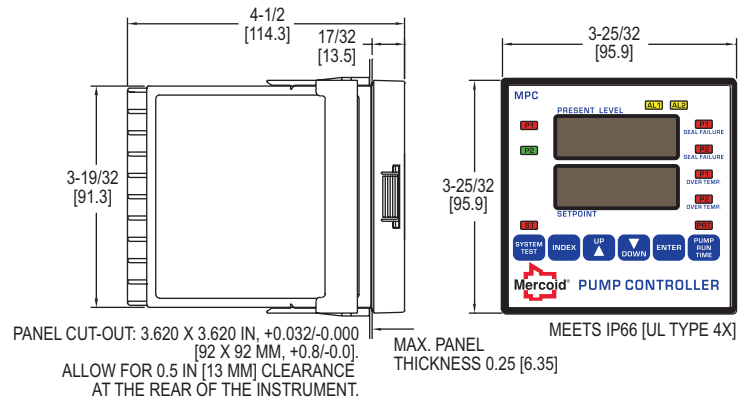

The **Series MPC Pump Controller** provides versatile level control in a standard 1/4 DIN package. Designed for use with almost any style level transmitter the unit displays the present level and main set point value. Incorporated in the MPC is programmable level differential for on/off control of one or two pumps, valves, or other devices through two SPDT relays.

## FEATURES/BENEFITS

- Selectable pump alternation when used with two pumps to minimize pump wear, with alternation "on" a seal failure or over temperature condition will force the non-failed pump to lead status and stop alternation
- Alarms can be programmed for output indication of pump seal failure or over temperature
- Selectable time delay, for pump two, on power up to prevent both pumps from starting at the same time
- In the event of power loss, upon regaining power a time delay of up to 60 seconds can be selected to prevent excessively large current draw
- Integral 24 VDC power supply to power level transmitter
- Displays pump run time from a front panel button
- Test system function simulates the process input to ensure the pumps are operating or to test programming
- User selectable security lock-out of programming and/or set points
- Process input retransmission as a current (4-20 mA) or voltage (2-10 VDC) analog signal (standard model MPC is set for current retransmission. For voltage retransmission add suffix "-RV")
- Two additional programmable alarm contacts with front alarm light indication
- Front panel face meets NEMA 4X for outdoor panel mounting
- User-friendly programming menu

## APPLICATIONS

- Water and wastewater
- Sump and sludge pits, clarifiers, digesters
- Chemical storage tanks
- Oil tanks
- Reservoirs

## SPECIFICATIONS

**Inputs:** 4 (or 0)-20 mA DC or 2 (or 0)-10 VDC selectable.  
**Input Impedance:** Current = 10 Ω; Voltage = 100 K Ω.  
**Output Ratings:** Control relays: SPDT, rated 10 A @ 240 VAC res., 1/4 hp @ 120 VAC, 1/3 hp @ 240 VAC; Alarm relays: SPST, 3 A @ 240 VAC res., 1/10 hp @ 120 VAC.  
**Control Type:** On/off, reverse (pump out) or direct (pump in) acting.  
**Power Requirements:** 100-240 VAC nominal, +10%-15%, 50 to 400 Hz, single phase; 132-240 VDC nominal, +10%-15%.  
**Power Consumption:** 7.5 VA max.  
**Accuracy:** ±0.25% of span, ±1 least significant digit.  
**Display:** Two 4 digit, 7 segment 0.56" high LED's.  
**Display Resolution:** 1 count.  
**Memory Backup:** Nonvolatile memory (no batteries required).  
**Serial Communications:** Optional RS-232 or RS-485 with Modbus® protocol.  
**Ambient Operating Temperature/RH:** 14 to 131°F (-10 to 55°C)/0 to 90% up to 104°F (40°C) non-condensing, 10 to 50% at 131°F (55°C) non-condensing.  
**Front Panel Rating:** Meets UL Type 4X (IP66).  
**Loop Power Supply (Isolated):** 24 VDC @ 50 mA, regulated.  
**Seal Failure (Moisture Sensor):** Power: 2.5 VDC; Search current: 3 micro amps; Resolution: 10K to 500K Ω in 10K Ω steps.  
**Weight:** 16 oz (454 g).  
**Agency Approvals:** cULus.

## MODEL CHART

Model	Description
MPC	Pump controller

## OPTIONS

To order add suffix:	Description
-232	RS-232 Modbus® RTU serial communications
-485	RS-485 Modbus® RTU serial communications

## ACCESSORIES

Weatherproof Enclosures, NEMA 4X (IP66). ●



A-901

Modbus® is a registered trademark of Schneider Automation, Inc.

Compatible Level Transmitters: See page 328 (Series SBLT2)  
See page 330 (Series PBLT2)

Additional Digital Control Panel Meters: See page 338 (Series APM/MPM/PPM)  
● See page 339 (Series A-900 & A-901)