

NEW

Quality and reliability is our tradition
KYORITSU

Ior LOGGER KEW 5050

Unprecedented Ior Logger!

Quickly find electric leakages with less time and more productivity.



Clamp sensors
in two different jaw sizes



- Providing simultaneous measurement and logging on 4-system
- Supporting various wiring systems (Single-phase 2&3-wire, Three-phase 3&4-wire)
- Less susceptible to harmonics
- World's fastest 200ms interval for Ior measurement
- Light weight with magnet on the back
- Offering traditional leakage / load current measurements as well

Find Quality Products Online at:

www.GlobalTestSupply.com

sales@GlobalTestSupply.com

KEW 5050 Specifications

Wiring configuration	1P2W, 1P3W, 3P3W, 3P4W
Measurements and parameters	lor: Leakage current (Trms) with resistive components only
	lo: Leakage current (Trms) with basic wave of 50/60Hz only
	lor: Leakage current (Trms) including harmonic components
	V: Reference voltage (Trms) with basic wave of 50/60Hz only
	Vm: Reference voltage (Trms) including harmonic components
R: Insulation resistance, Frequency(Hz), Phase angle(θ)	
Other functions	Digital output, Print screen, Back light, Data hold
Recording Interval	200/400ms/1/5/15/30s/1/5/15/30/60/120m
lor	
Range	10.000/100.00/1000.0mA/10.000A/AUTO
Accuracy	$\pm 0.2\%rdg \pm 0.2\%f.s.$ + clamp sensor amplitude accuracy*1 + error of phase accuracy*2 *1) Clamp sensor amplitude accuracy:sensor accuracy excluding the error range. *2) add $\pm 2.0\%rdg$ to measured lo value when using lor leakage clamp sensor. (θ : within the accuracy of reference voltage/ current phase difference $\pm 1.0^\circ$)
Allowable input	1% - 110% (Trms) of each range, and 200% (peak) of the range
Display range	0.15% - 130% (display "0" for less than 0.15%, "OL" if the range is exceeded)
lo *Range, Allowable input and Display Range are the same as lor	
Accuracy	$\pm 0.2\%rdg \pm 0.2\%f.s.$ + clamp sensor amplitude accuracy
lor *Range, Allowable input and Display Range are the same as lor	
Accuracy	$\pm 0.2\%rdg \pm 0.2\%f.s.$ + clamp sensor amplitude accuracy
Measurement method	Sampling speed 40.96ksps (every 24.4 μ s), gapless, calculate Trms values every 200ms.
Voltage	
Range	1000.0V
Accuracy	$\pm 0.2\%rdg \pm 0.2\%f.s.$ * for waveforms of sine wave 40 - 70 Hz
Allowable input	10 - 1000 V Trms, and 2000 Vpeak
Display range	0.9 V - 1100.0 V Trms (display "0" for less than 0.9 V, "OL" if the range is exceeded)
Phase angle(θ)	
Display range	0.0° to $\pm 180.0^\circ$ (regarding the phase of reference voltage as 0.0°)
Accuracy	Within $\pm 0.5^\circ$ for the inputs of 10% or higher of leakage current range, sine wave 40 - 70 Hz reference voltage of 90 V Trms or higher.
Frequency meter range	40 - 70Hz
External supply	AC100 - 240V(50/60Hz) 7VAmax

Power source	LR6(AA)(1.5V) x 6 (Battery life approx. 11 h)
Display / update period	160 x 160 dots, FSTN monochrome display / 500 ms
PC card interface	SD card (2GB) *standard accessory
PC communication-interface	USB Ver2.0
Temperature and humidity range	23 \pm 5 °C, less than 85%RH(without condensation)
Operating temperature and humidity range	-10 to 50°C less than 85%RH(without condensation)
Storage temperature and humidity range	-20 to 60°C less than 85%RH(without condensation)
Applicable Standards	IEC61010-1 CAT IV, 300V CAT III 600V Pollution degree 2 IEC61010-2-030, IEC61010-031, IEC61326
Dimension/Weight	165(L)X115(W)X57(D)mm/approx. 680g (including batteries)
Included accessories	7273(Voltage test lead)
	8262(AC adapter)
	7278(Earth cable)
	7219(USB cable)
	8326-02(SD card 2GB)
	9125(Carrying case)
Instruction manual, Cable marker, Software installation manual Alkaline size AA battery(LR6)x6 KEW Windows for KEW 5050(software)	
Optional accessories	8177(lor Leakage clamp sensor 10A type ϕ 40mm)
	8178(lor Leakage clamp sensor 10A type ϕ 68mm)
	8329(Power supply adapter)
	KEW 8146, 8147, 8148 (Leakage & Load clamp sensor)
	KEW 8141, 8142, 8143 (Leakage clamp sensor)
	KEW 8129, 8130 (Flexible sensor)
	KEW 8121, 8122, 8123 (Load clamp sensor)
	MODEL 8124, 8125, 8126, 8127, 8128 (Load clamp sensor)

Shows insulation resistance (R) values determined by the following formula.
V: Reference voltage/ lor: Leakage current with resistive components only
Displayed value is just for reference since the measurement method differs from insulation resistance testers and may not be consistent with each other.

Accessories



MODEL 7273
Voltage test lead
3000mm



MODEL 8262
AC adapter



MODEL 7278
Earth Cable
1500mm



MODEL 7219
USB Cable
1500mm



MODEL 8326-02
SD Card



MODEL 9125
Carrying case



KEW Windows
for KEW 5050
Software

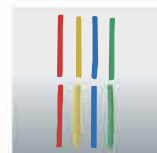

Cable marker

Optional



KEW 8178
lor Leakage clamp
sensor 10A type
 ϕ 68mm(3m)



KEW 8177
lor Leakage clamp
sensor 10A type
 ϕ 40mm(3m)

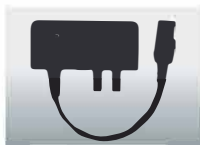

MODEL 8329
Power supply adapter

Set model



KEW 5050-00
Basic Model(main unit only)

KEW 5050-01 [Set Model]



KEW 8178 x 1
lor Leakage clamp
sensor 10A type
 ϕ 68mm(3m)

KEW 5050-02 [Set Model]



KEW 8177 x 1
lor Leakage clamp
sensor 10A type
 ϕ 40mm(3m)



Safety Warnings :

Please read the "Safety Warnings" in the instruction manual supplied with the instrument thoroughly and completely for correct use. Failure to follow the safety rules can cause fire, trouble, electrical shock, etc. Therefore, make sure to operate the instrument on a correct power supply and voltage rating marked on each instrument.

For inquires or orders :



**KYORITSU ELECTRICAL
INSTRUMENTS
WORKS, LTD.**

Tests and records 4-system simultaneously in 200 ms gapless

Can measure 4 systems at once!

Best to diagnose circuit breaker problems

Measures Ior and Ioc separately to clarify the root cause of the electric leakage troubles.

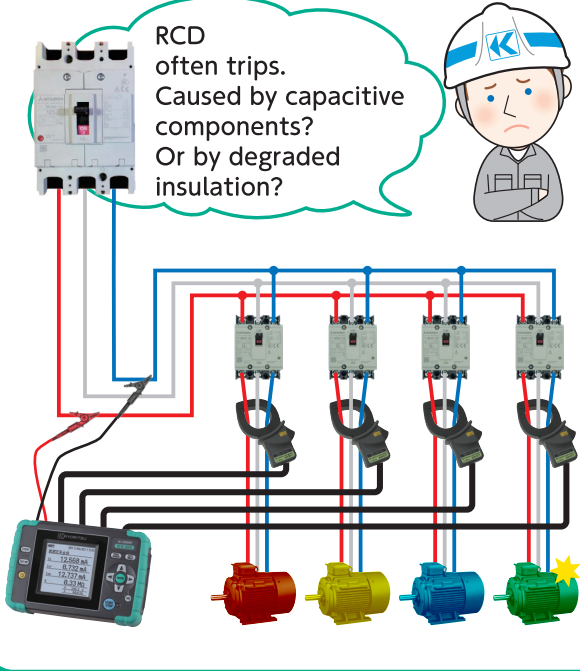

Accessories and optional parts

Optional Power supply adapter is available to derive power via measurement terminal.

Cable markers for easy recognition



USB terminal

Allows connection with PC and access to SD card

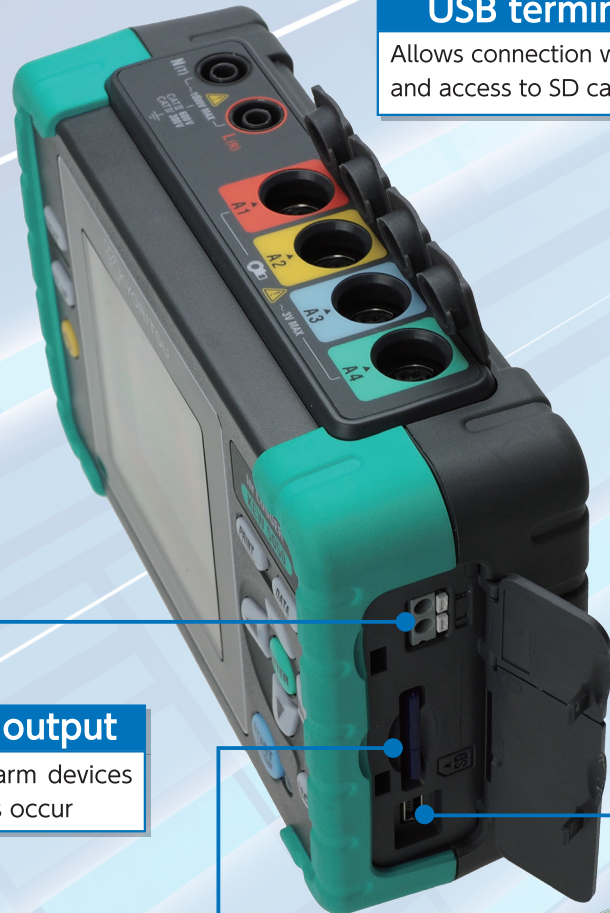

Digital output

Activates alarm devices when events occur

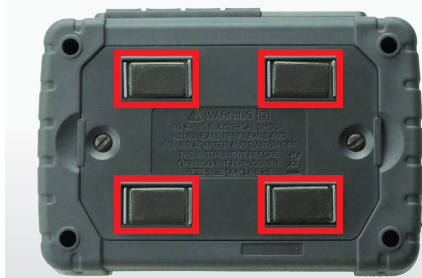

Strong magnets help to fix Kew5050 to the metal distribution board.

SD card interface

Achieves long period of data logging. In case of sudden power interruption, data stored in the SD card aren't lost.

Interval	Possible recording time (with 2GB SD card)		
	REC item	1P3W×1	1P3W×4
200ms	25days	8days	7days
1sec	38days	11days	9days
2sec	76days	22days	18days
5sec	6.5months	1.8months	1.5months
15sec	1-year or more	4months	5months

Special data analysis software

One-click graph and list generation. Visualizes timeline based graphs for easy analysis.

Data can be checked without using this software by changing the file extension to csv or others.

Viewing data without using the software is possible by renaming the file with a CSV extension.

[System Requirements]

- OS: Windows® 10/ 8/ 7
 - Display: XGA (1024 × 768) or higher
 - HDD: 1Gbyte or more
- Others: CD-ROM drive, USB port, .NET Framework 3.5, 4.6
- * Windows® is a registered trademark.

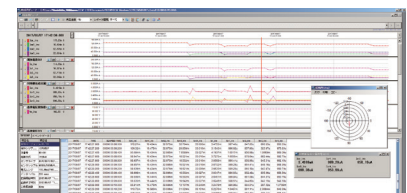

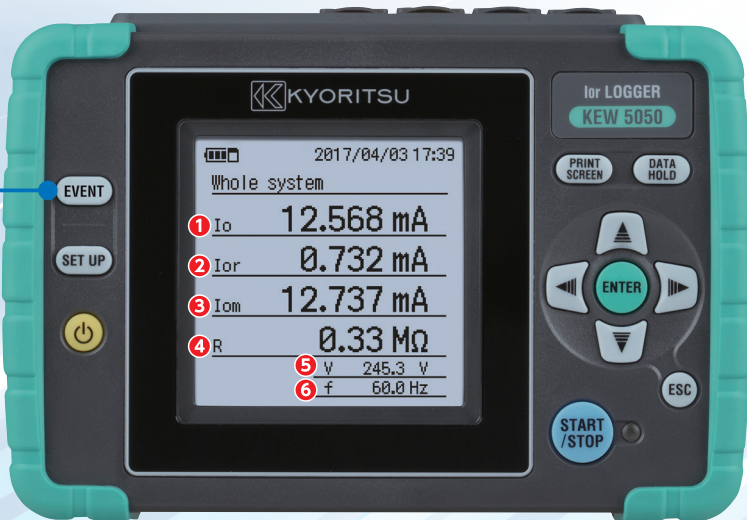

- 1 I_o Leakage current (1st-order component of I_{om})
- 2 I_{or} Resistive leakage current
- 3 I_{om} Leakage current with harmonics
- 4 R Insulation resistance (determined by V and I_{or})
- 5 V Reference voltage (1st-order component of V_m)
- 6 f Frequency

EVENT Quickly displays occurred events

Detailed information on the occurred events are displayed on the LCD. Different threshold values can be set for each channel and each event.

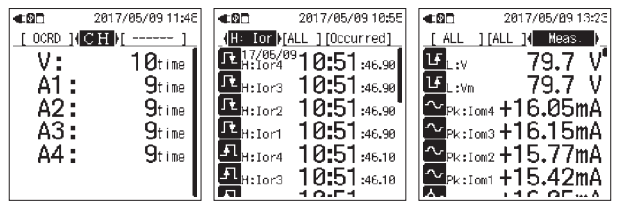

Various display modes

User-friendly graphical display of connections and phase differences.

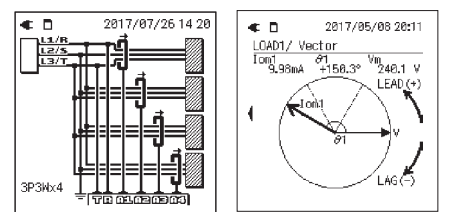

New measurement method with FFT

Offering accurate I_{or} measurement without being affected by noises or harmonics

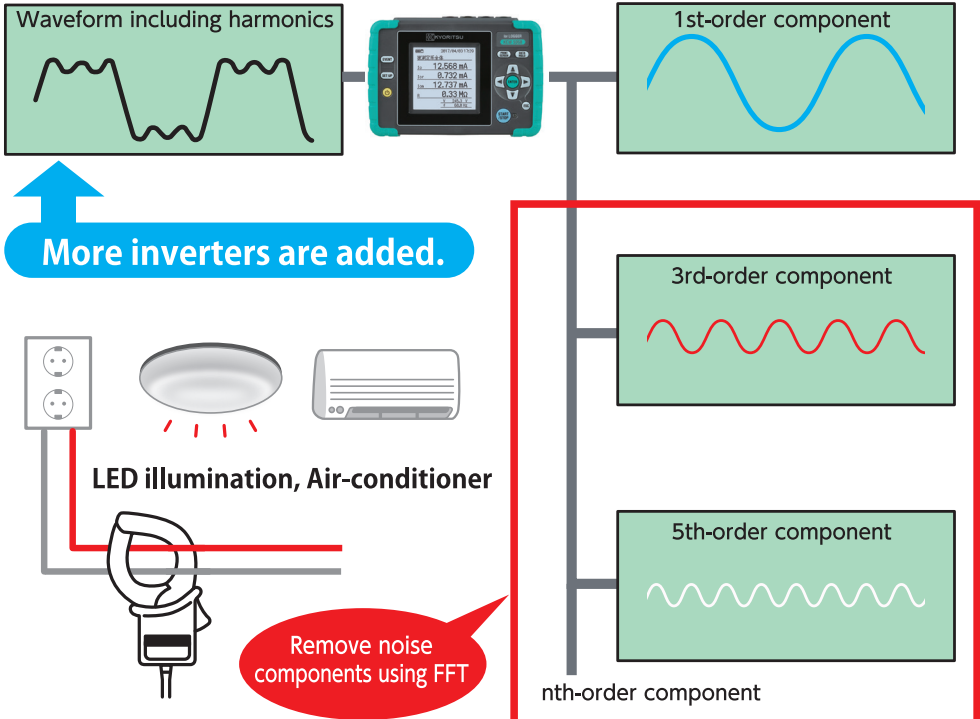

Never miss intermittent leakages
Gapless continuous measurement

Performs fast sampling (24.4 μsec) continuously with gapless during logging to prevent intermittent leakages being overlooked as an event or max value.

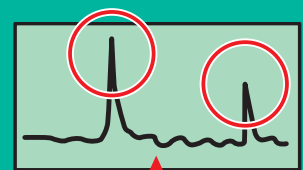

No I_{or} measuring devices which can record intermittent leakages?

Unlike to traditional I_{or} measuring apparatus, less susceptible to harmonics noises. Successfully achieving logging with no effects of harmonics by Trms calculation every 200 ms using FFT (Fast Fourier Transform).