

H921



Hawkeye® 921

Installer's Specifications

Sensor Power	30mA (max.)@12-30VDC
Insulation Class	600VAC rms (UL), 300VAC rms (CE)
Frequency	50/60Hz
Temperature Range	-15° to 60°C (5° to 140°F)
Humidity Range	10-90% RH non-condensing
Amperage Range	0-30/60/120 Amps (slide-switch selectable)
Output	4-20mA DC
Hysteresis	10% of setpoint, typical
Off-State Leakage	1+ MΩ
Safety	UL 508, IEC 61010-1: 2001 CAT III

Specification Note: For CE compliance, conductor shall be insulated according to IEC 61010-1:2001, Installation Category III or equivalent.
The product design provides for basic insulation only.

QUICK INSTALL

1. Disconnect and lock out power to the conductor to be monitored.
2. Plan the installation:
Locate a mounting surface for the removable mounting bracket that will allow the monitored conductor to pass through the iris, or "window" when it is installed and keep the product at least 1/2" (13mm) from any uninsulated conductors (CE). Determine cable routing for the controller connection, allowing wiring to reach the mounting location.
3. Install mounting bracket
Drill holes to mount the bracket to the chosen surface using the included screws.
4. Set the desired amperage range (30, 60, or 120 Amps).
5. Wire the output connections between the sensor and the controller (4-20mA).
6. Snap the sensor over the wire to be monitored and clip the assembly to the mounting bracket.
7. Scale the controller software to match the selected output.

DIMENSIONS

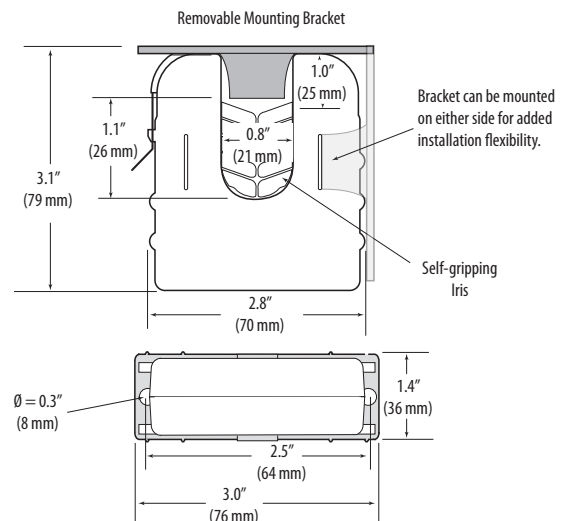

DANGER

HAZARD OF ELECTRIC SHOCK, EXPLOSION, OR ARC FLASH

- Follow safe electrical work practices. See NFPA 70E in the USA, or applicable local codes.
- This equipment must only be installed and serviced by qualified electrical personnel.
- Read, understand and follow the instructions before installing this product.
- Turn off all power supplying equipment before working on or inside the equipment.
- Use a properly rated voltage sensing device to confirm power is off.
DO NOT DEPEND ON THIS PRODUCT FOR VOLTAGE INDICATION
- Only install this product on insulated conductors.

Failure to follow these instructions will result in death or serious injury.

NOTICE

- This product is not intended for life or safety applications.
- Do not install this product in hazardous or classified locations.
- The installer is responsible for conformance to all applicable codes.
- Mount this product inside a suitable fire and electrical enclosure.

WIRING EXAMPLE

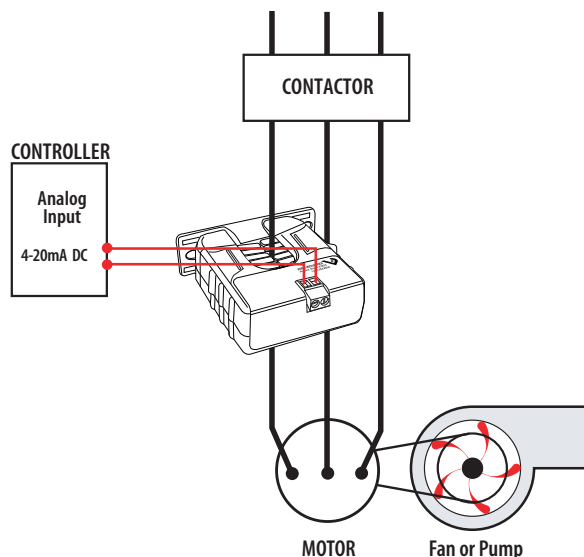

OPERATION

The H921 is a current transducer that senses current (amperage) in any of three field-selectable ranges; zero-to-thirty, zero-to-sixty, or zero-to-one hundred twenty amperes. These ranges represent the maximum current that can be applied to the monitored conductor. The H921 transforms the monitored current into 4-20mA DC output suitable for connection to building controllers or other appropriate data acquisition equipment. The H921 requires 12-30VDC external power to generate its output.

The H921 housing offers unprecedented mounting flexibility. The mounting bracket can be attached in three different places. Additionally, the bracket is compatible with the Veris AH01 DIN Rail clip, allowing DIN mounting.

NOTES

For load currents greater than sensor maximum rating:

Use a 5 Amp (H68xx series) Current Transformer (CT) as shown.

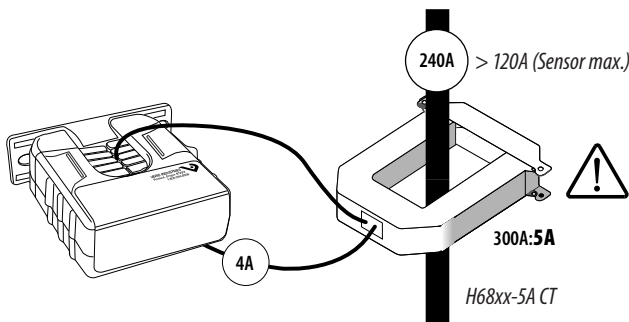

DANGER: 5A CTs can present hazardous voltages. Install CTs in accordance with manufacturer's instructions. Terminate the CT secondary before applying current.

CAUTION

RISK OF EQUIPMENT DAMAGE

- Derate the product's maximum current for the number of turns through the sensing window using the following formula.

$$\text{Rated Max. Amps} \div \text{Number of Turns} = \text{Max. monitored Amps}$$
 e.g. : $100A \div 4 \text{ Turns} = 25 \text{ Amps max. in monitored conductor}$
- Failure to follow these instructions can result in overheating and permanent equipment damage.

For load currents less than sensor minimum rating:

Wrap the monitored conductor through the center hole and around the sensor body to produce multiple turns through the "window." This increases the current measured by the transducer.

Controller must be programmed to account for the extra turns. e.g., if three turns pass through the sensor (as shown) the normal controller reading must be divided by 3.

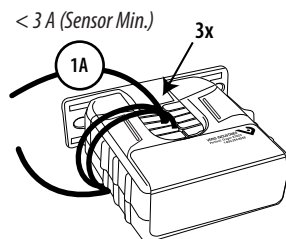

WIRING

External Power

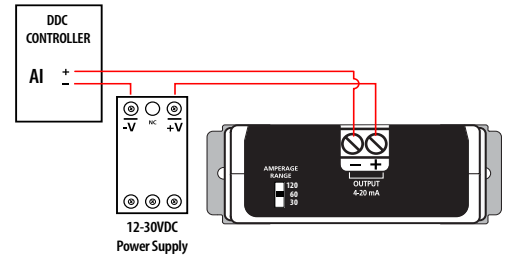

Sourcing Panel (-Common)

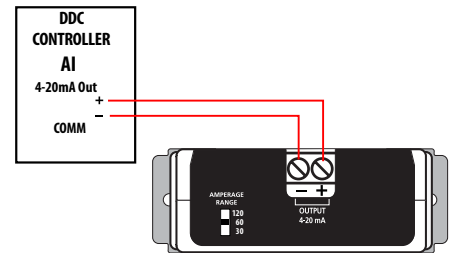

Sinking Panel (+Common)

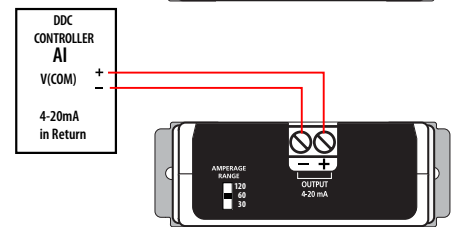

*A resistor can be added in parallel to convert the 4-20mA signal to a VDC signal (250 ohm = 1-5VDC); (500 ohm = 2-10VDC)

SCALING

1. Set range switch.

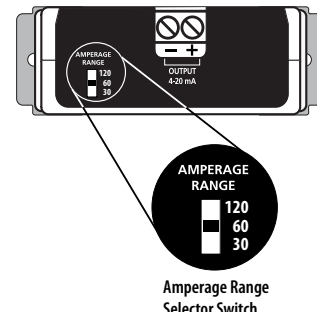

2. Scale controller software to match selected output.

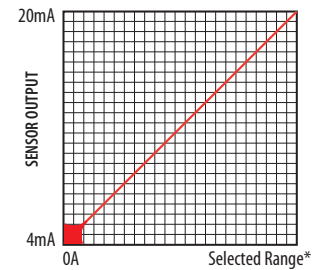

SENDER AMPS
 *Factory calibrated ranges selected with the amperage range switch

TROUBLESHOOTING

Problem	Solution
No Reading at Controller	<ul style="list-style-type: none"> • Confirm that you have 12-30VDC in series with the sensor output terminals and the control panel analog input • Assure that sensor core mating surfaces are clean and that the core clamp is completely closed.