



Acuvim II Series Power Meter AXM-WEB-PUSH User's Manual



ACCUEVERGY

The information contained in this document is believed to be accurate at the time of publication, however, Accuenergy assumes no responsibility for any errors which may appear here and reserves the right to make changes without notice. Please ask the local representative for latest product specifications before ordering.

Please read this manual carefully before installation, operation and maintenance of the AcuRev 1310 series meter. The following symbols in this manual are used to provide warning of danger or risk during the installation and operation of the meters.



Electric Shock Symbol: Carries information about procedures which must be followed to reduce the risk of electric shock and danger to personal health.



Safety Alert Symbol: Carries information about circumstances which if not considered may result in injury or death.

Prior to maintenance and repair, the equipment must be de-energized and grounded. All maintenance work must be performed by qualified, competent accredited professionals who have received formal training and have experience with high voltage and current devices. Accuenergy shall not be responsible or liable for any damages or injuries caused by improper meter installation and/or operation.

ACCUENERGY

V: 2.0 Revised: Sept. 2018



Contents

1. Introduction to Ethernet.....	4
2. Functional Description of the Ethernet module.....	4
3. Appearance and Dimensions	4
4. Installation Method	5
5. Definition of RJ45	6
6. Initializing the Ethernet module	7
7. Cable	13
8. Connection method	14
8.1 Direct Connect to a Computer.....	14
8.2 Direct Connect to Router/Switch	17
9. Description of Modbus-TCP Protocol	18
9.1 Protocol.....	18
9.1.1 Data Frame Format.....	18
9.1.2 Modbus Application Header (MBAP Header) Field	18
9.1.3 Function Field	19
9.1.4 Data Field.....	19
9.2 Format of communication	20
9.2.1 Read Status of Relay (Function code 01)	21
9.2.2 Read Status of DI(Function Code 02)	22
9.2.3 Read Data (Function Code 03)	23
9.2.4 Control Relay(Function Code05).....	24
9.2.5 Preset/Reset Multi-Register(Function Code 16)	25

10. Web Interface Readings and Parameter Settings	26
10.1 User Access Login	26
10.2 Dashboard	27
10.3 Metering web page	28
Basic Metering:	29
Power & Energy:	30
Min/Max:	30
THD:	31
Harmonics:	32
Phase Angles:	33
Sequence:	33
10.4 Status web page	34
Device Information:	35
Alarm Status:	35
I/O:	36
SOE:	37
10.5 Settings web page	37
Meter Setting:	38
Communication:	40
Network:	41
Emails:	42
Time/Date:	45
Datalog:	46
AcuCloud Post:	52
SNMP:	53
Management:	55
Firmware:	55

Acuvim II Series - AXM WEB PUSH

1. Introduction to Ethernet

Ethernet was originally developed by Xerox and then further developed by DEC and Intel. This networking technology uses Carrier Sense Multiple Access with Collision Detection (CDSM/CD) protocol and provides transmission speeds up to 100Mbps.

Ethernet is not a network but more of a standard. It is the most current communication standard Local Area Network(LAN). This standard defines the type of cable that is used and the method of Signal Processing.

2. Functional Description of the Ethernet module

Please read the Technical Data and specifications of the Ethernet module in the Appendix prior to using it.

The AXM-WEB-PUSH module supports the Modbus-TCP protocol. When connected to the Acuvim II series meter, it is a slave device that can only respond to queries. The default value for the Modbus Port is 502. The user defined range is 2000~5999.

The AXM-WEB-PUSH supports the SMTP protocol. It has the ability to send emails based on a time interval or when there is a triggered event. It can send mail from encrypted servers and servers that use different SMTP ports.

The AXM-WEB-PUSH protocol supports HTTPS protocol. It is used as an HTTPS server and the default value of the protocol port is 443.

Using the HTTPS protocol, the AXM-WEB-PUSH can send post requests to both HTTP and HTTPS servers.

3. Appearance and Dimensions

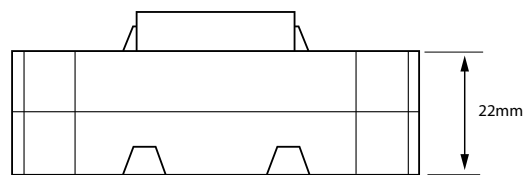

(Side View)

Chapter 4: Installation Method

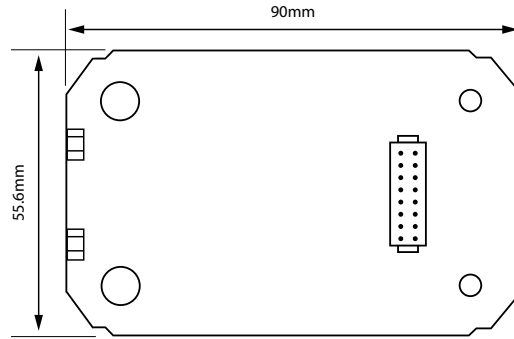

(Top View)

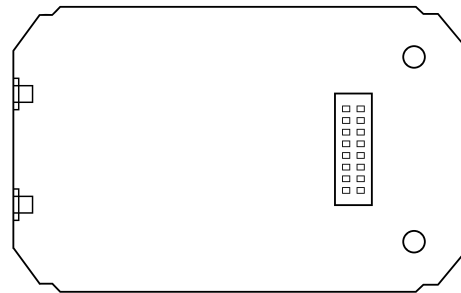

(Bottom View)

4. Installation Method

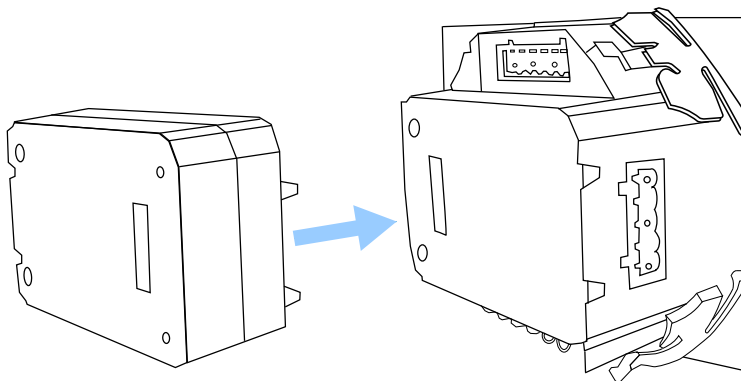

ACCUENERGY

V: 2.0 Revised: Sept. 2018

5

Chapter 5: Definition of RJ45

The AXM-WEB-PUSH module is linked to the Acuvim II series meter by a communication plug. Other extended modules such as the IO modules can be linked to the Acuvim II series meter through the AXM-WEB-PUSH.

1. Remove cover from the back of the Acuvim II series meter which will expose the socket.
2. Insert the installation clips to the grooves in the Acuvim II series meter and then press the AXM-WEB-PUSH module lightly to establish a linking between meter and module.
3. Tighten the installation screws.

Note: Installation with power to the meter is forbidden.

5. Definition of RJ45

The AXM-WEB-PUSH uses a standard RJ45 connector to access the Ethernet network. The mechanical and electrical characteristics of the connector are consistent with the requirements of IEC 603-7.

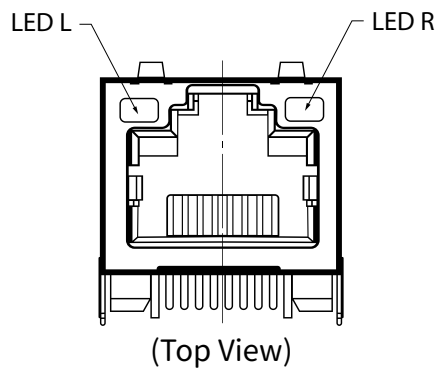

Script	ID	Content
1	TX+	Tranceive Data+
2	TX-	Tranceive Data-
3	RX+	Receive Data+
4	n/c	Not connected
5	n/c	Not connected
6	RX-	Receive Data-
7	n/c	Not connected
8	n/c	Not connected

Chapter 6: Initializing the Ethernet module

LED_L (Yellow): Displays the speed status. When the LED is on it indicates 100Mbps, while an off LED represents a speed of 10Mbps.

LED_R (Green): Displays the link and activity status. When the LED is on it indicates that the link status. When the LED is flashing it indicates that there is activity.

6. Initializing the Ethernet module

The default settings in the Acuvim II series meter are as followed:

- **IP Address (192.168.1.254);**
- **Subnet Mask (255.255.255.0);**
- **Gateway (192.168.1.1);**
- **Primary DNS Server (202.106.0.20);**
- **Modbus Port 502**

This information can be found by using the buttons from the meter display. The following is how to configure the Ethernet module settings from the display:

- Press the 'H' and 'V/A' buttons simultaneously on the Acuvim II series. Release the buttons and the meter will enter the meter selecting mode, as indicated by the flashing 'Meter' cursor.

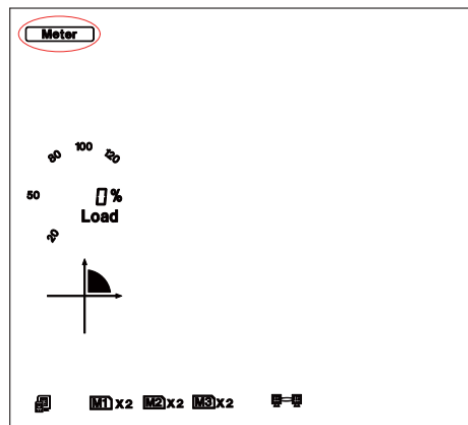

Acuvim II Series - AXM WEB PUSH

- Press the 'P' or 'E' button to move the cursor to 'Setting'. Press 'V/A' button to enter the parameter setting mode. The device address page is the first page of the 'Setting' mode. It will show the Modbus address of the meter for a second before prompting for the password of the device. Press 'V/A' button to confirm password and enter the parameter setting page. Press the 'P' or 'E' button to move the cursor to 'NET' and press the 'V/A' button to enter the Ethernet module settings.

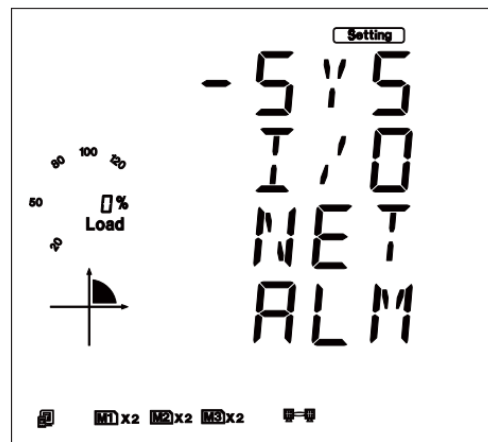
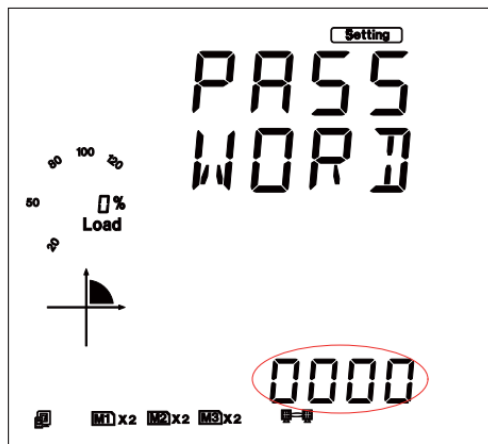

Chapter 6: Initializing the Ethernet module

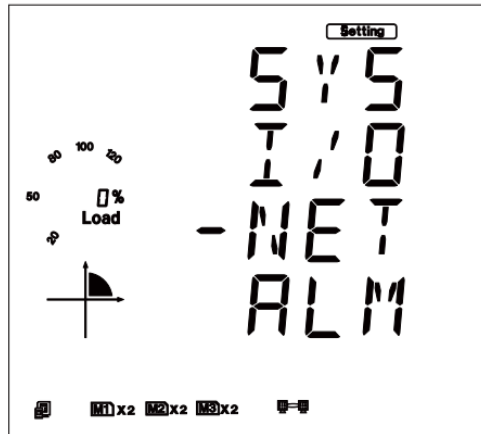

- The first page of the NET Settings will be the N01 DHCP setting. By default this is configured to Manual. Setting this configuration to Auto will allow the router to assign the meter with an IP address, while Manual will allow the user to configure the IP address. Press the 'V/A' button to enter edit mode. Press 'P' or 'E' to change the setting and press 'V/A' to confirm.

Note: If the DHCP is selected as Auto, the Ethernet module needs to be rebooted before it can be assigned with the new IP address.



Acuvim II Series - AXM WEB PUSH

- Press 'P' to get to "N02 IP address". This is the IP address of the meter and will be the IP address to access the web interface of the module. Users can configure the IP address if the DHCP is configured to Manual. Press 'V/A' to configure the IP address. The cursor of the first digit will begin to flash. Press the 'H' button to scroll through the digits, press the 'P' or 'E' to change the value of the flashing cursor and press 'V/A' to confirm.

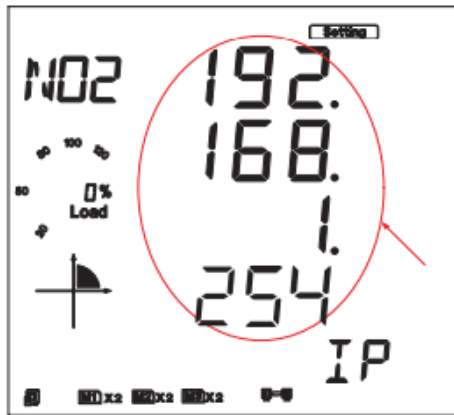

- Press 'P' to get to "N03 Subnet Mask". Press 'V/A' to configure the subnet address. The cursor of the first digit will begin to flash. Press the 'H' button to scroll through the digits, press the 'P' or 'E' to change the value of the flashing cursor and press 'V/A' to confirm.

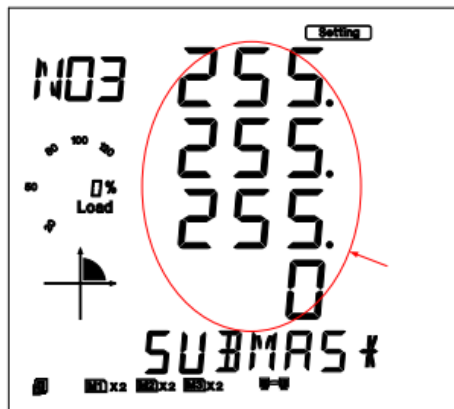

Chapter 6: Initializing the Ethernet module

- Press 'P' to get to "N03 Subnet Mask". Press 'V/A' to configure the subnet address. The cursor of the first digit will begin to flash. Press the 'H' button to scroll through the digits, press the 'P' or 'E' to change the value of the flashing cursor and press 'V/A' to confirm.

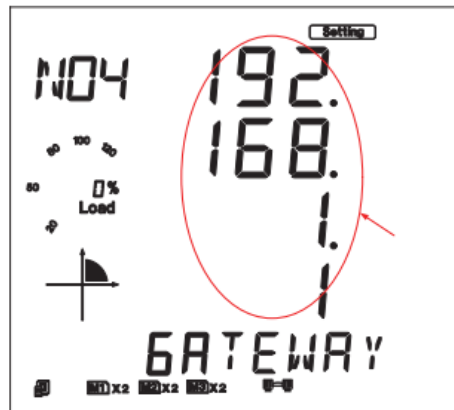

- Press 'P' to get to "N05 DNS Primary Server". Press 'V/A' to configure the DNS address. The cursor of the first digit will begin to flash. Press the 'H' button to scroll through the digits, press the 'P' or 'E' to change the value of the flashing cursor and press 'V/A' to confirm. The DNS parameters must be set correctly to use the SMTP, FTP/HTTP Post and AcuCloud functions.

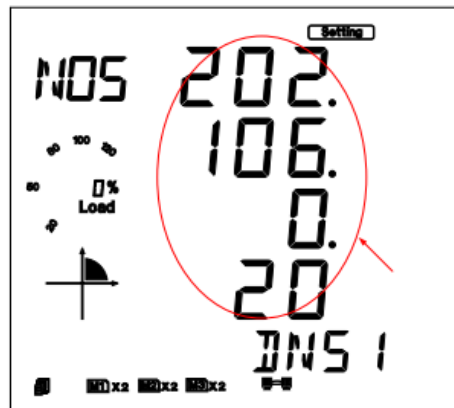

Acuvim II Series - AXM WEB PUSH

- Press 'P' to get to "N06 DNS Secondary Server". Press 'V/A' to configure the DNS address. The cursor of the first digit will begin to flash. Press the 'H' button to scroll through the digits, press the 'P' or 'E' to change the value of the flashing cursor and press 'V/A' to confirm.

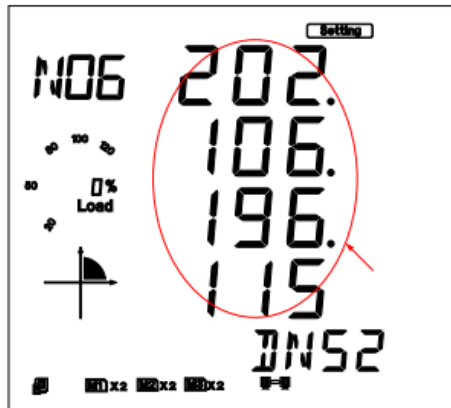

- Press 'P' to get to "N07 Modbus Port". Press 'V/A' to configure the Modbus Port. The cursor of the first digit will begin to flash. Press the 'H' button to scroll through the digits, press the 'P' or 'E' to change the value of the flashing cursor and press 'V/A' to confirm.

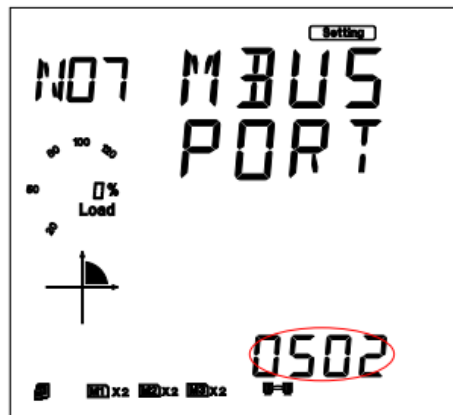

- Press 'P' to get to "N09 NET REST". After making any changes to the NET settings, users must reboot the Ethernet module from this page for the settings to take effect. Press 'V/A' to reboot the module, the cursor will begin to flash. Press the 'P' or 'E' button to change the setting to 'Reset' and press 'V/A' to confirm. The cursor will return to 'No' once successful.



After configuring the AXM-WEB-PUSH module, press the 'H' and 'V/A' buttons simultaneously to return to the menu selection.

7. Cable

An RJ45 cable is needed to connect the meter to the network. A shielded twisted pair cable (standard 568A or standard 568B) is recommended as reference to the EIA/TIA standard.

8. Connection method

8.1 Direct Connect to a Computer

The AXM-WEB-PUSH can be connected to a computer using a crossover cable(standard 568A). The AXM-WEB-PUSH module supports Modbus-TCP and HTTPS Functions for this method of connection.

To connect meter directly to the computer, the following can be done using a computer running the Windows OS:

- Manually connect the meter via Ethernet cable to the computer
- Right click on the connection icon
- Select "Open Network Sharing Center"

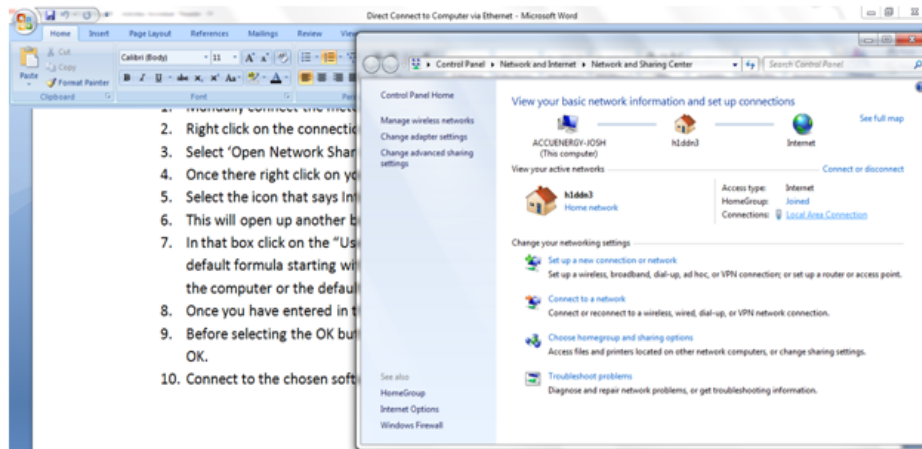

Chapter 8: Connection Method

- Once there right click on the local area connection icon and click properties

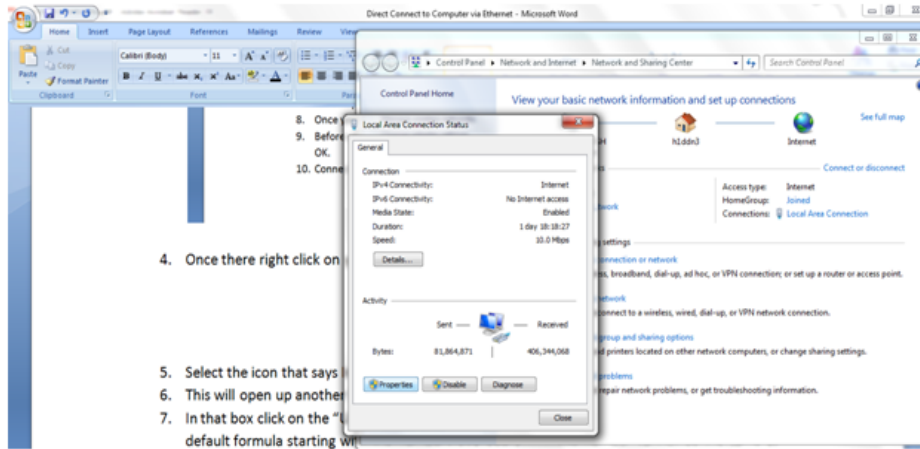

- Select the icon that says Internet Protocol Version 4 TCP/IP

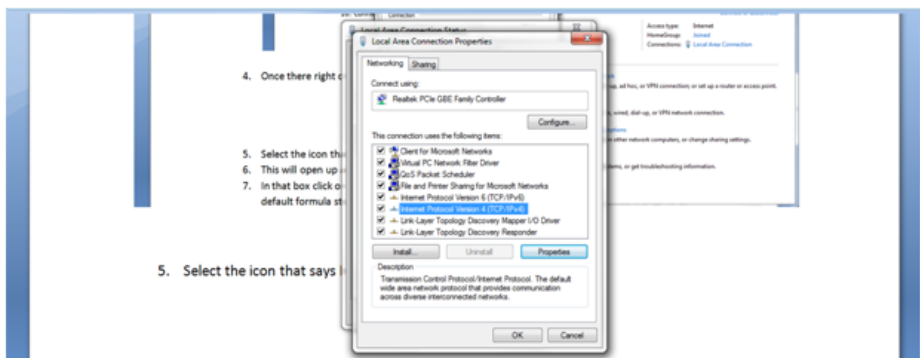

Acuvim II Series - AXM WEB PUSH

- The Internet Protocol Version 4(TCP/IP) Properties box will pop up

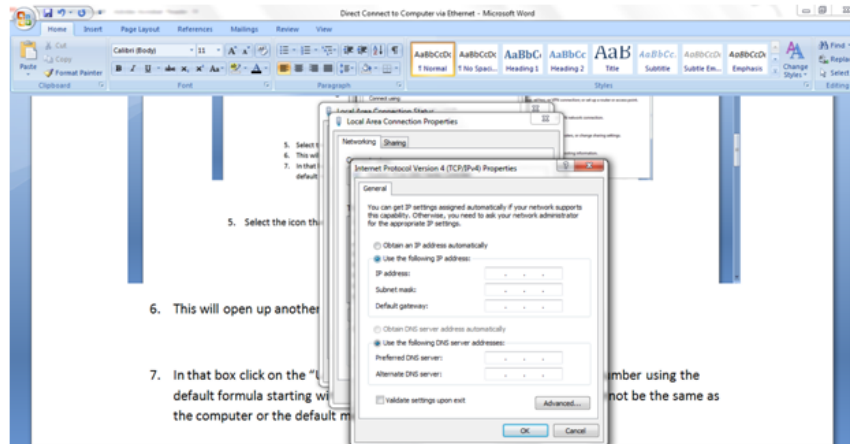

- Click on “Use the following IP address” and enter in an IP number so that meter and computer are in the same local network range. For example, if the meter has IP address of 192.168.1.254, then the computer must be assigned with a IP 192.168.1.xxx, where xxx can be any number but cannot be the same as the value the meter has

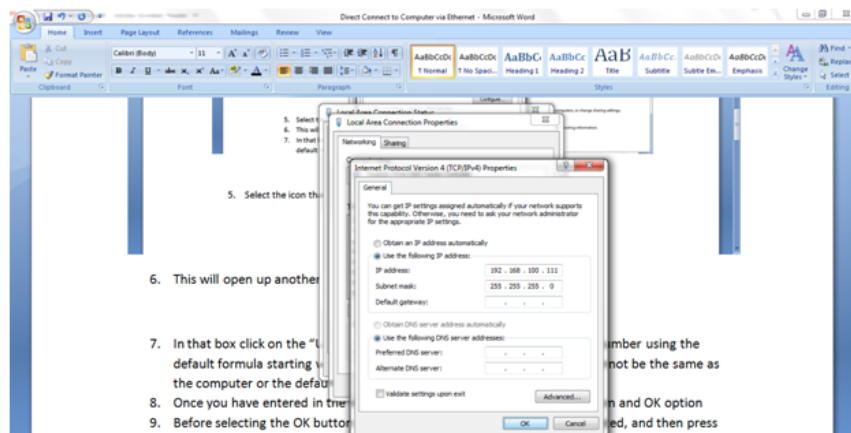

- Once you have entered in the IP address, press the Tab key on your keyboard until you hit the bottom and click OK
- Before selecting the OK button make note of the IP address you have assigned to the meter and then press OK.

8.2 Direct Connect to Router/Switch

The AXM-WEB-PUSH can be connected to a router or switch using a patch cable. The DHCP can be configured to Auto to have the router assign the meter with an IP address or the DHCP can be configured to Manual to set an IP address using the information in Chapter 5.

9. Description of Modbus-TCP Protocol

The Modbus-TCP protocol is used as one of the communication protocols in the AXM-WEB-PUSH. The protocol establishes a master and slave connection in Ethernet. The master device (client) first sets up a TCP-IP link with slave device (server). The master device then sends a request to the slave device and the slave device in return sends a response to the master device. Figure ... shows how the Modbus-TCP protocol works.

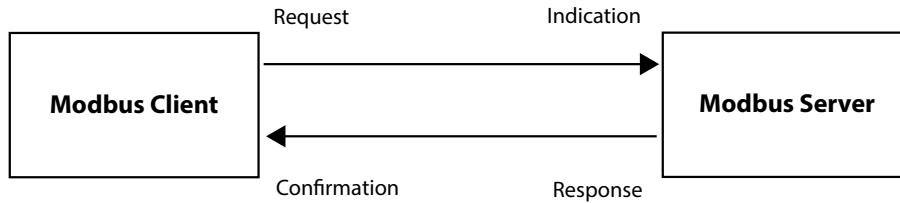

9.1 Protocol

9.1.1 Data Frame Format

MBAP Header	Function	Data
7x8-Bits	8-Bits	Nx8-Bits

9.1.2 Modbus Application Header (MBAP Header) Field

Code	Meaning	Action
Transaction Identifier	2 Bytes	Identification of a Modbus Request/Response transaction
Protocol Identifier	2 Bytes	Modbus protocol = 0
Length	2 Bytes	Number of following bytes
Unit Identifier	1 Byte	Slave address, in the range of 0-247 decimal.

9.1.3 Function Field

The function code field of a message frame contains eight bits. Valid codes are in the range of 1-255. When a message is sent from a client to as server device the function code field tells the server what kinds of action to perform.

Code	Meaning	Action
01	Read Relay Output Status	Obtain current status of Relay Output
02	Read Digital Input (DI) Status	Obtain current status of Digital Input
03	Read Data	Obtain current binary value in one or more registers
05	Control Single Relat Output	Force Relay to a state of in or off
16	Write Multiple-registers	Place specific value into a series of consecutive multiple-registers

9.1.4 Data Field

The data field is constructed using sets of two hexadecimal digits, in the range of 00 to FF. The data field of messages sent from a master to slave contains additional information which the slave must use to take the action defined by the function code. This can include information such as the register addresses, the quantity of registers to query and the count of the actual number of data bytes. For example, if the master requests a slave to read a group of holding registers(function code 03) and the data field specifies the starting register and how many registers are to be read.

If the master needs to perform a write to a group of registers in the slave(function code 10 hexadecimal), the data field specifies the starting register, how many registers to write, the count of data bytes to follow in the data field and the data to be written into the registers.

9.2 Format of communication

Explanation of frame

Transaction identifier hi	Transaction identifier lo	Protocol identifier hi	Protocol identifier lo	Length hi	Length lo	Unit identifier
00H	00H	00H	00H	00H	06H	01H

Fun	Data start reg hi	Data start reg lo	Data #of regs hi	Data #of regs lo
03H	40H	00H	00H	48H

The meaning of each abbreviated field above is:

Transaction identifier hi: High byte of transaction identifier

Transaction identifier lo: Low byte of transaction identifier

Protocol identifier hi: High byte of protocol identifier

Protocol identifier low: Low byte of protocol identifier

Length hi: High byte of length

Length lo: Low byte of length

Unit identifier: Slave address

Fun: Function code

Data start reg hi: High byte of starting register address

Data start reg lo: Low byte of starting register address

Data #of regs hi: High byte of number of registers

Data #of regs lo: Low byte of number of registers

Chapter 9: Description of Modbus-TCP Protocol

9.2.1 Read Status of Relay (Function code 01)

This function code is used to read the relay output status in the Acuvim II series meter.

1=On 0=Off

There are 8 relay outputs in the Acuvim II series meter and they start at address 0000H.

The following query is to read 2 relay output status of the AcuvimII series address 1.

Query

Transaction identifier hi	Transaction identifier lo	Protocol identifier hi	Protocol identifier lo	Length hi	Length lo	Unit identifier
00H	00H	00H	00H	00H	06H	01H

Fun	Data start reg hi	Data start reg lo	Data #of regs hi	Data #of regs lo
01H	00H	00H	00H	02H

Response

The Acuvim II series meter responds back with the MBAP header, function code, quantity of data bytes and the data.

An example of response to read the status of the first 2 relay outputs starting at 0000H is shown below. The status of relay output 1 and 2 is corresponds to the last 2 bits of data.

Relay 1: bit0 Relay 2:bit1

Transaction identifier hi	Transaction identifier lo	Protocol identifier hi	Protocol identifier lo	Length hi	Length lo	Unit identifier
00H	00H	00H	00H	00H	04H	01H

Fun	Byte count	Data
02H	01H	02H

Acuvim II Series - AXM WEB PUSH

The content of the data is,

7	6	5	4	3	2	1	0
0	0	0	0	0	0	1	0

MSB

LSB

(Relay 1 = OFF, Relay 2 = ON)

9.2.2 Read Status of DI(Function Code 02)

1=On 0=Off

There are 28 DIs in the Acuvim II series meter starting at address 0000H.

The following query is to read 4 DI statuses of AXM-IO1 module with logic address of 1 in the Acuvim II series meter.

Query

Transaction identifier hi	Transaction identifier lo	Protocol identifier hi	Protocol identifier lo	Length hi	Length lo	Unit identifier
00H	00H	00H	00H	00H	06H	01H

Fun	Data start reg hi	Data start reg lo	Data #of regs hi	Data #of regs lo
02H	00H	00H	00H	04H

Response

The response includes the MBAP header, function code, quantity of data characters and the data.

An example response from the meter to read the status of 4 DIs(DI1=On, DI2=On, DI3=On, DI4=On) is shown below. The status of each corresponds to the last 4 bits of the data.

Chapter 9: Description of Modbus-TCP Protocol

DI1: bit0		DI2:bit1		DI3:bit2		DI4:bit3	
Transaction identifier hi	Transaction identifier lo	Protocol identifier hi	Protocol identifier lo	Length hi	Length lo	Unit identifier	
00H	00H	00H	00H	00H	04H	01H	

Fun	Byte count	Data
02H	01H	0FH

The content of the data is,

7	6	5	4	3	2	1	0
0	0	0	0	1	1	1	1

MSB

LSB

9.2.3 Read Data (Function Code 03)

Query

This function allows the user to obtain the measurement results of the Acuvim II series meter.

Below is an example to read 6 registers corresponding to the device clock of the meter, starting at 1040H.

Transaction identifier hi	Transaction identifier lo	Protocol identifier hi	Protocol identifier lo	Length hi	Length lo	Unit identifier
00H	00H	00H	00H	00H	06H	01H

Fun	Data start reg hi	Data start reg lo	Data #of regs hi	Data #of regs lo
03H	10H	40H	00H	06H

Acuvim II Series - AXM WEB PUSH

An example response is provided to read the time (2006-12-18 14:15:20).

Transaction identifier hi	Transaction identifier lo	Protocol identifier hi	Protocol identifier lo	Length hi	Length lo	Unit identifier
00H	00H	00H	00H	00H	06H	01H

Fun	Data count	Data1 hi	Data1 lo	Data2 hi	Data2 lo	Data3 hi	Data3 lo	Data4 hi	Data4 lo	Data5 hi	Data5 lo	Data6 hi	Data6 lo
03H	0CH	07H	D6H	00H	0CH	00H	12H	00H	0EH	00H	0FH	00H	14H

9.2.4 Control Relay(Function Code05)

Query

This function code enables the control of a single relay output in the Acuvim II series meter. Any relay output in the Acuvim II series meter can be controlled on or off starting at 0000H.

Sending the data 'FF00H' will set they relay output on and sending '0000H' will turn it off; all other values are illegal and will not affect they relay output status.

The example below is a request to a Acuvim II series meter to turn on relay output 1.

Transaction identifier hi	Transaction identifier lo	Protocol identifier hi	Protocol identifier lo	Length hi	Length lo	Unit identifier
00H	00H	00H	00H	00H	06H	01H

Fun	Data start reg hi	Data start reg lo	Data #of regs hi	Data #of regs lo
05H	00H	00H	FFH	00H

Response

The normal response to the command request is to retransmit the message as received after the relay output status has been altered.

Chapter 10: Web Interface Readings and Parameter Settings

Transaction identifier hi	Transaction identifier lo	Protocol identifier hi	Protocol identifier lo	Length hi	Length lo	Unit identifier
00H	00H	00H	00H	00H	06H	01H

Fun	Data start reg hi	Data start reg lo	Value hi	Value lo
05H	00H	00H	FFH	00H

9.2.5 Preset/Reset Multi-Register(Function Code 16)

Query

This function code allows the user to modify the contents of a register. The example below is a request to an Acuvim II series meter with device address 1 to preset the CT1(500) and CT2(5) registers. The CT1 data address is 1008H and CT2 is at 1009H.

Transaction identifier hi	Transaction identifier lo	Protocol identifier hi	Protocol identifier lo	Length hi	Length lo	Unit identifier
00H	00H	00H	00H	00H	06H	01H

Fun	Data start reg hi	Data start reg lo	Data #of regs hi	Data #of regs lo	Byte count	Value1 h1	Value1 lo	Value2 hi	Value2 lo
10H	10H	08H	00H	02H	04H	01H	F4H	00H	05H

Response

The normal response to a preset Multi-Register request including the MBAP Header, function code, data start register and the number of registers is shown below.

Transaction identifier hi	Transaction identifier lo	Protocol identifier hi	Protocol identifier lo	Length hi	Length lo	Unit identifier
00H	00H	00H	00H	00H	06H	01H

Fun	Data start reg hi	Data start reg lo	Data #of regs hi	Data #of regs lo
10H	10H	08H	00H	02H

10. Web Interface Readings and Parameter Settings

The AXM-WEB-PUSH module supports the HTTPS protocol to allow for the use of a web interface. The user will need to visit access the AXM-WEB-PUSH web interface to configure the module and use its functions. The web interface allows for remote initial setup of the Acuvim II meter.

The AXM-WEB-PUSH web interface allows for different user access levels.

In the following cases, the IP address of the module will be "192.168.1.161".

10.1 User Access Login

Enter the correct IP address of the module in the search bar of the internet browser to access the web interface of the AXM-WEB-PUSH.

The user will be redirected to a webpage prompting to select the Access Level and enter appropriate password for that level.

The User level is ideal for users who need only to take readings and view status from the meter.

The default password for the User level is '*view*'.

It is recommended that no more than 5 users are logged in at the same time for this level to ensure optimal performance of web interface.

The Admin level is ideal for users who need access to configurations on the meter or the web interface and to view readings.

The default password for the Admin level is '*admin*'.

The AXM-WEB-PUSH web interface will only allow one admin to be logged in at a time. If another user logs in at this access level, the previous user will be logged out.

The two different access levels are summarised below:

Chapter 10: Web Interface Readings and Parameter Settings

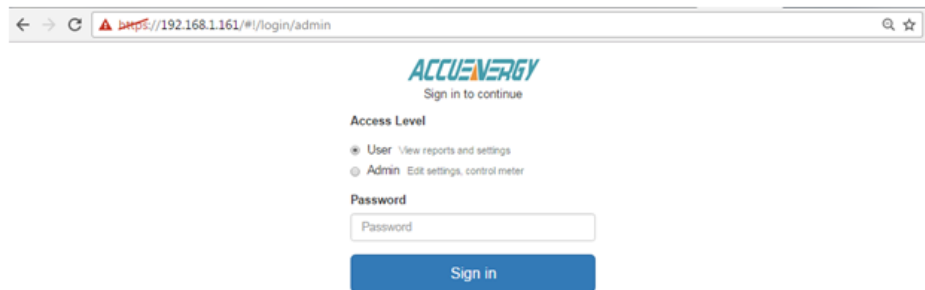

Access Level	Default Password	Read Parameter/Status	Configure Settings
User	view	Yes	No
Admin	admin	Yes	Yes

10.2 Dashboard

In the dashboard, the user will find the tabs to access different pages in the web interface such as 'Metering', 'Status', and 'Settings'. The dashboard is the first page the user will see once they have entered the correct password for the appropriate access level. The dashboard is the same for both access levels.

The dashboard displays selected parameters from the different groups of metering parameters such as "Basic Metering", "Power & Energy", 'THD' and "Max Demand". Clicking on "Full report" under any one of these four metering parameter groups will take the user to the webpage which contains all the parameters supported by that metering parameter group.

The dashboard also displays how long the AXM-WEB-PUSH module has been connected to the network since the last reboot of the module in the bottom left corner of the page.

The parameters on this page are updated every 5 sec.

NOTE: If user is logged in with 'User' access, clicking on 'Settings' will automatically log the

Acuvim II Series - AXM WEB PUSH

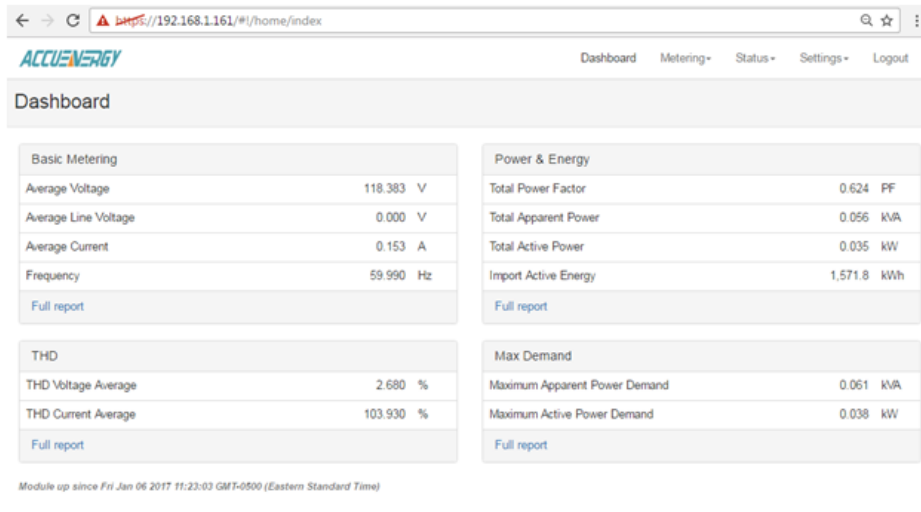

Dashboard

Basic Metering	
Average Voltage	118.383 V
Average Line Voltage	0.000 V
Average Current	0.153 A
Frequency	59.990 Hz
Full report	

Power & Energy	
Total Power Factor	0.624 PF
Total Apparent Power	0.056 kVA
Total Active Power	0.035 kW
Import Active Energy	1,571.8 kWh
Full report	

THD	
THD Voltage Average	2.680 %
THD Current Average	103.930 %
Full report	

Max Demand	
Maximum Apparent Power Demand	0.061 kVA
Maximum Active Power Demand	0.038 kW
Full report	

Module up since Fri Jan 06 2017 11:23:03 GMT-0500 (Eastern Standard Time)

user out from the web interface.

10.3 Metering web page

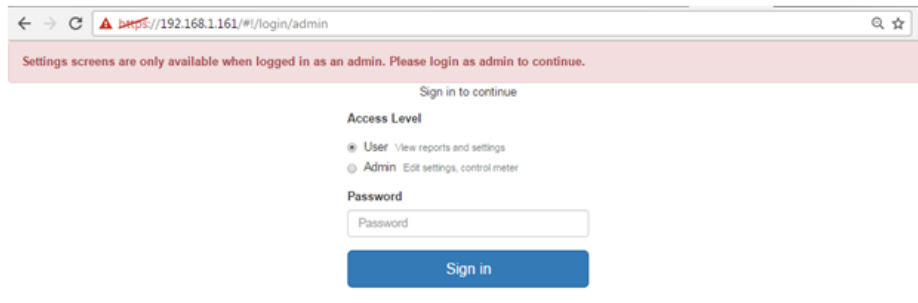

Settings screens are only available when logged in as an admin. Please login as admin to continue.

Sign in to continue

Access Level

- User View reports and settings
- Admin Edit settings, control meter

Password

Sign in

Click on the 'Metering' tab to visit the metering data web pages. There are seven kinds of metering parameter web pages. They are "Basic Metering", "Power & Energy", "Min/Max", "THD", "Harmonics", "Phase Angles" and 'Sequence'. Each webpage shows data from the Acuvim II series meter.

Chapter 10: Web Interface Readings and Parameter Settings

The screenshot shows the AccuEnergy web interface dashboard. The browser address bar displays `https://192.168.1.161/#/home/index`. The dashboard includes a navigation menu with 'Dashboard', 'Metering', 'Status', 'Settings', and 'Logout'. A dropdown menu is open under 'Metering', listing options: 'Basic Metering', 'Power & Energy', 'Min/Max', 'THD', 'Harmonics', 'Phase Angles', and 'Sequence'. The main content area is divided into several sections:

- Basic Metering:**

Average Voltage	114.877 V
Average Line Voltage	0.000 V
Average Current	0.153 A
Frequency	59.980 Hz
- Power & Energy:**

Total Power Factor	0.645 PF
Total Apparent Power	0.053 kVA
Total Active Power	0.034 kW
Import Active Energy	1.571.9 kWh
- THD:**

THD Voltage Average	2.910 %
THD Current Average	98.610 %
- Max Demand:**

Maximum Apparent Power Demand	0.061 kVA
Maximum Active Power Demand	0.038 kW

At the bottom of the dashboard, a status message reads: "Module up since Tue Jan 10 2017 10:35:40 GMT-0500 (Eastern Standard Time)".

Basic Metering:

The Basic Metering webpage includes the data of real-time parameters for the Acuvim II series meter. This includes the Line Voltages, Phase Voltages, Current, Neutral Current, Active, Reactive and Apparent Power, Power Factor, Frequency and Load type.

The parameters on this page are updated every 5 sec.

The values displayed in this webpage will depend on the wiring configuration mode of the meter. For example, if the meter is configured as '3LL' then the metering webpage will display '0.00' for the Phase Voltages.

The screenshot shows the 'Basic Metering' page in the AccuEnergy web interface. The browser address bar displays `https://192.168.1.161/#/readings/basic`. The page title is 'Metering Basic Metering'. The main content is a table with the following data:

Parameter	Phase A	Phase B	Phase C	Average	Total
Line Voltage V	118.694	118.723	118.447	118.621	-
Phase Voltage V	0.000	0.000	0.000	0.000	-
Current A	0.149	0.149	0.149	0.149	-
Neutral Current A	-	-	-	-	0.000
Active Power kW	0.011	0.011	0.011	-	0.034
Reactive Power kvar	-0.005	-0.005	-0.005	-	-0.014
Apparent Power kVA	0.018	0.018	0.018	-	0.053
Power Factor	0.645	0.645	0.645	-	0.645
Frequency Hz	60.000				
Load Type	C				

Acuvim II Series - AXM WEB PUSH

Power & Energy:

The Power & Energy webpage shows the energy data for the Acuvim II series meter such as the Active and Reactive energy that is consumed and delivered as well as the Apparent energy per phase and total.

This webpage also shows the Demand parameters for the Active, Reactive and Apparent Power as well as the three phase Current demands.

The parameters in this webpage are updated every 5 sec.

The screenshot shows the 'Power & Energy' page in the Acuvim II Series AXM WEB PUSH interface. The page is titled 'Metering Power & Energy' and contains three data tables.

Energy by Consumption/Generation

Parameter	Import	Export	Total	Net
Active Energy kWh	1,571.900	6.600	1,578.500	1,565.300
Reactive Energy kvarh	2.900	710.100	713.000	-707.200
Apparent Energy kVAh	-	-	-	2,487.100

Energy by Phase

Parameter	Phase A	Phase B	Phase C
Import Active Energy	523.8	523.8	523.1
Export Active Energy kWh	2.1	2.1	2.1
Import Reactive Energy kvarh	0.9	0.9	0.9
Export Reactive Energy kvarh	236.2	236.2	235.9
Apparent Energy kVAh	828.8	829.0	827.6

Demand

Parameter	Phase A	Phase B	Phase C	Total
Active Power Demand kW	-	-	-	0.035
Reactive Power Demand kvar	-	-	-	-0.015
Apparent Power Demand kVA	-	-	-	0.054
Current Demand A	0.154	0.154	0.154	-

Min/Max:

The Min/Max page shows the maximum and minimum statistics that the meter has records since the lifetime of the meter or from the last reset of the min/max statistics as well as the timestamps they were recorded at.

The parameters in this webpage are updated every 10 sec.

Chapter 10: Web Interface Readings and Parameter Settings

Parameter	Min	Min Timestamp	Max	Max Timestamp
Phase A Voltage V	0.000	2016-09-22 17:06:31	127.500	2016-09-02 22:20:43
Phase B Voltage V	0.000	2016-09-22 17:06:31	127.600	2016-09-02 22:20:45
Phase A Voltage V	0.000	2016-09-22 17:06:31	127.300	2016-09-02 22:20:44
Line Voltage AB V	0.000	2016-09-02 20:11:40	0.000	2016-09-02 20:11:40
Line Voltage BC V	0.000	2016-09-02 20:11:40	0.000	2016-09-02 20:11:40
Line Voltage CA V	0.000	2016-09-02 20:11:40	0.000	2016-09-02 20:11:40
Phase A Current A	0.000	2016-09-22 17:06:31	0.209	2016-11-09 13:13:25
Phase B Current A	0.000	2016-09-22 17:06:31	0.209	2016-11-09 13:13:25
Phase C Current A	0.000	2016-09-22 17:06:31	0.210	2016-11-09 13:13:25
Active Power kW	-0.041	2016-11-21 09:09:01	0.042	2016-09-23 09:26:40
Reactive Power kvar	-0.021	2016-11-18 16:36:06	0.020	2016-11-21 09:09:08
Apparent Power vA	0.000	2016-09-08 18:40:28	0.067	2016-11-09 13:13:25
Power Factor	-0.678	2016-11-28 10:51:13	1.000	2016-09-08 18:40:28
Frequency Hz	0.000	2016-09-08 18:40:28	60.200	2017-01-06 10:15:30
Active Power Demand kW	-0.036	2016-11-21 23:12:00	0.038	2016-09-03 10:43:50
Reactive Power Demand kvar	-0.018	2016-09-03 10:22:50	0.017	2016-11-25 20:38:12
Apparent Power Demand vA	0.000	2016-09-02 20:11:40	0.061	2016-09-03 14:28:54
Unbalance Voltage Demand %	0.000	2016-09-02 20:11:40	6.800	2016-11-16 09:44:32
Unbalance Current Demand %	0.000	2016-09-02 20:11:41	99.600	2016-11-29 11:20:43
THD Voltage A %	0.000	2016-09-08 18:40:28	6.210	2016-09-12 09:24:39
THD Voltage B %	0.000	2016-09-08 18:40:28	6.210	2016-09-12 09:24:39
THD Voltage C %	0.000	2016-09-08 18:40:28	6.140	2016-09-12 09:24:39

THD:

The THD webpage shows the power quality data such as the THD, THFF, Crest and K Factor for both the voltage and current.

The parameters in this webpage are updated every 15 sec.

Parameter	Phase A	Phase B	Phase C
THD Voltage %	2.800	2.810	2.770
THD Current %	96.700	99.160	98.350
THD Odd Line Voltage %	2.770	2.790	2.770
THD Even Line Voltage %	0.420	0.410	0.000
Crest Factor Line Voltage	1.487	1.483	1.488
THFF Line Voltage %	1.150	1.100	1.040
THD Odd Current %	96.480	98.790	97.820
THD Even Current %	6.560	8.570	10.290
K Factor Current	65.300	60.500	66.300

Acuvim II Series - AXM WEB PUSH

Harmonics:

The Harmonics webpage will show the harmonics of the voltage and the current waveform being measured. It will display the harmonics of each phase in graphical and tabular format. Select between voltage and current to view their respective harmonics as well as between the 2nd-31st harmonics or 32nd-63rd from the drop down list.

The parameters in this webpage are updated every 15 sec.

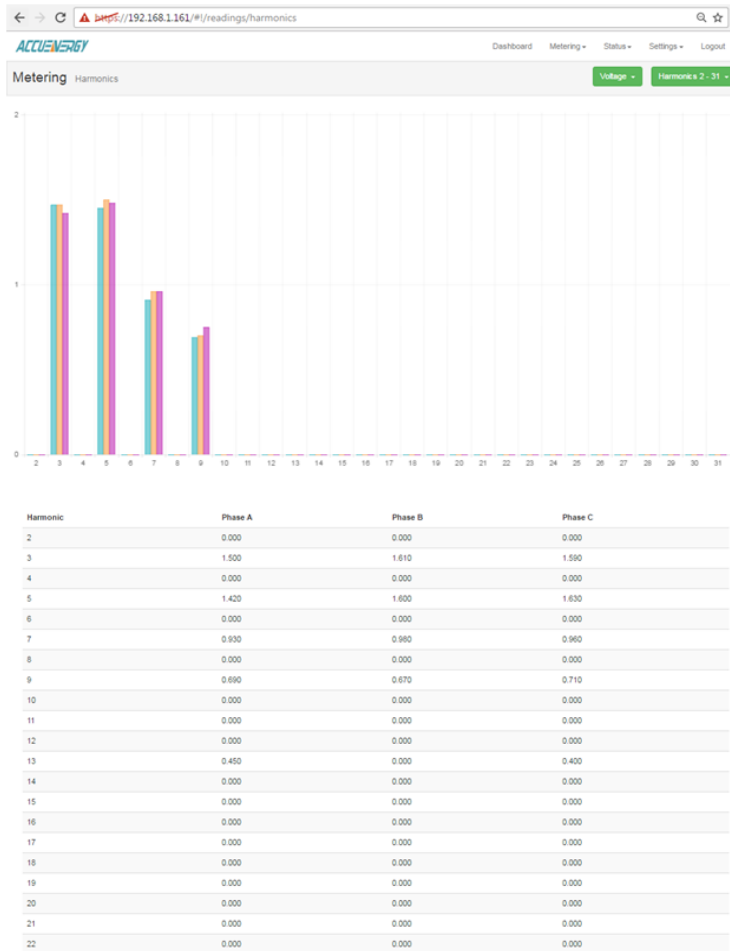

Chapter 10: Web Interface Readings and Parameter Settings

Phase Angles:

The Phase Angles webpage will show the phase angles of the voltage and current waveform being measured which can be used for remote troubleshooting. This page provide a visual diagram of the phase angles with respect to the voltage connected to the Phase A voltage input.

The parameters in this webpage are updated every 5 sec.

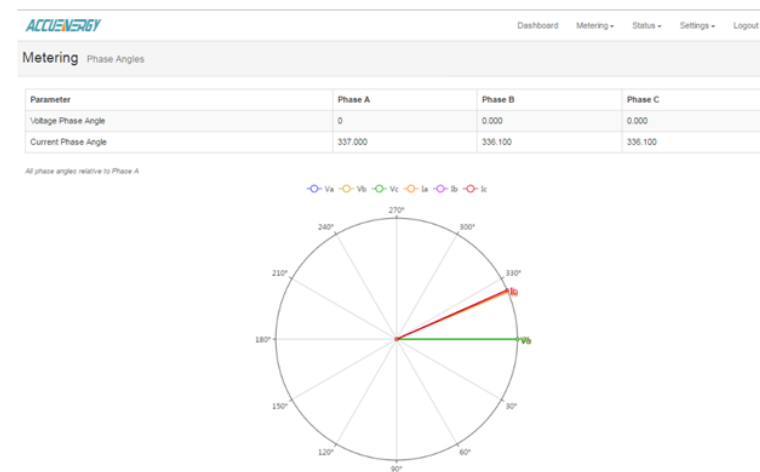

Sequence:

The Sequence webpage will show the positive, negative and zero components of the voltage and current waveform being measured.

The parameters in this webpage are updated every 15 sec.

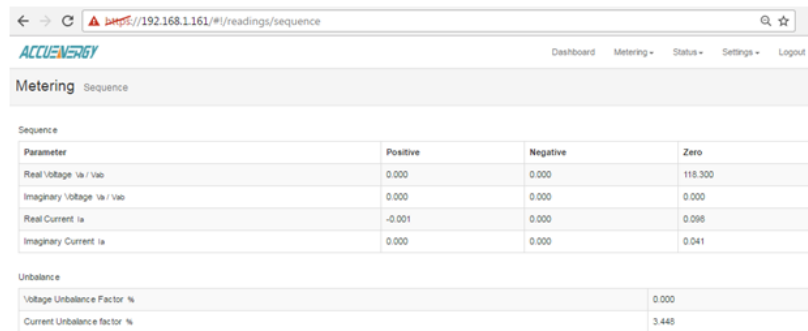

Acuvim II Series - AXM WEB PUSH



10.4 Status web page

Click on the 'Status' tab to visit the status parameter web pages. There are four kinds of status web pages. They are "Device Information", "Alarm Status", 'I/O' and 'SOE' statuses. Each web-page shows different statuses or information about the Acuvim II series meter.

Dashboard Metering **Status** Settings Logout

Dashboard

- Device Information
- Alarm Status
- I/O
- SOE

Basic Metering	
Average Voltage	117.531 V
Average Line Voltage	0.000 V
Average Current	0.152 A
Frequency	59.980 Hz
Full report	

Power & Energy	
Total Power Factor	0.649 PF
Total Apparent Power	0.053 kVA
Total Active Power	0.035 kW
Import Active Energy	1,571.9 kWh
Full report	

THD	
THD Voltage Average	2.820 %
THD Current Average	98.460 %
Full report	

Max Demand	
Maximum Apparent Power Demand	0.061 kVA
Maximum Active Power Demand	0.038 kW
Full report	

Module up since Tue Jan 10 2017 11:19:05 GMT-0500 (Eastern Standard Time)

Chapter 10: Web Interface Readings and Parameter Settings

Device Information:

The Device Information webpage shows information about the Acuvim II series meter and AXM-WEB-PUSH module. It will contain the model of the Acuvim II series meter, serial number, firmware version and meter addresses. It also contains the serial number, hardware and firmware version as well as the MAC address of the AXM-WEB-PUSH module.

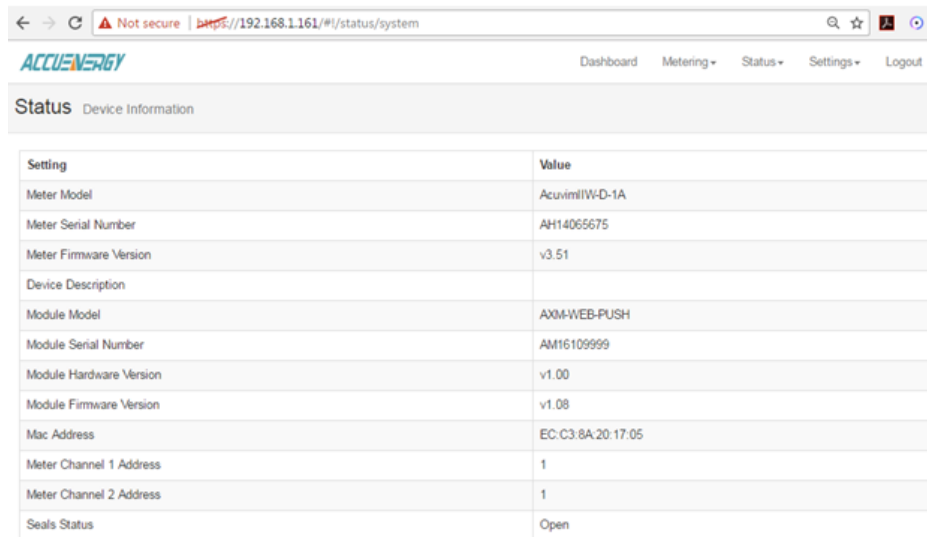

The screenshot shows a web browser window with the URL `http://192.168.1.161/#/status/system`. The page title is "Status" and the subtitle is "Device Information". The AccuEnergy logo is in the top left, and navigation links for "Dashboard", "Metering", "Status", "Settings", and "Logout" are in the top right. A table lists various settings and their values.

Setting	Value
Meter Model	AcuvimIIW-D-1A
Meter Serial Number	AH14065675
Meter Firmware Version	v3.51
Device Description	
Module Model	AXM-WEB-PUSH
Module Serial Number	AM16109999
Module Hardware Version	v1.00
Module Firmware Version	v1.08
Mac Address	EC-C3-8A-20-17-05
Meter Channel 1 Address	1
Meter Channel 2 Address	1
Seals Status	Open

Alarm Status:

The alarm status webpage shows the alarm log of the meter. It will show the status of up to 16 alarm events indicating the alarm ID, status, parameter, value and timestamp of the alarm event.

Once all 16 alarm events are full, the newest alarm event will then wrap around to alarm 1.

The parameters in this webpage are updated every 10 sec.

Acuvim II Series - AXM WEB PUSH

	Alarm ID	Status	Parameter	Value	Timestamp
Alarm 1	1	Alarm	Frequency	60.000Hz	2017-01-05 09:39:08.478
Alarm 2	1	Cleared	Frequency	0.000Hz	2017-01-10 11:17:38.443
Alarm 3	1	Alarm	Frequency	60.020Hz	2017-01-10 11:18:52.857
Alarm 4	0	Cleared	Frequency	0.000Hz	0000-00-00 00:00:00.000
Alarm 5	0	Cleared	Frequency	0.000Hz	0000-00-00 00:00:00.000
Alarm 6	0	Cleared	Frequency	0.000Hz	0000-00-00 00:00:00.000
Alarm 7	0	Cleared	Frequency	0.000Hz	0000-00-00 00:00:00.000
Alarm 8	0	Cleared	Frequency	0.000Hz	0000-00-00 00:00:00.000
Alarm 9	0	Cleared	Frequency	0.000Hz	0000-00-00 00:00:00.000
Alarm 10	0	Cleared	Frequency	0.000Hz	0000-00-00 00:00:00.000
Alarm 11	0	Cleared	Frequency	0.000Hz	0000-00-00 00:00:00.000
Alarm 12	0	Cleared	Frequency	0.000Hz	0000-00-00 00:00:00.000
Alarm 13	0	Cleared	Frequency	0.000Hz	0000-00-00 00:00:00.000
Alarm 14	0	Cleared	Frequency	0.000Hz	0000-00-00 00:00:00.000
Alarm 15	0	Cleared	Frequency	0.000Hz	0000-00-00 00:00:00.000
Alarm 16	0	Cleared	Frequency	0.000Hz	0000-00-00 00:00:00.000

I/O:

The I/O webpage will display the status of the I/O modules that are connected and their values depending on the model of the module that is connected to the meter. I.E. The AXM-IO11 module will display the Relay Output status(on/off), DI status/counter.

The parameters in this webpage are updated every 5 sec.

Module	Status	Parameter 1	Parameter 2	Parameter 3	Parameter 4
AXM-IO11 Module	Online				
AXM-IO12 Module	Online				
AXM-IO21 Module	Online	Analog Output	AO1: 19.639mA	AO2: 10.537mA	
AXM-IO22 Module	Online	Digital Input	DI1 Counter: 261567	DI2 Counter: 0	DI3 Counter: 0, DI4 Counter: 261567
AXM-IO31 Module	Online	Relay Output	RO1: <input type="checkbox"/>	RO2: <input type="checkbox"/>	
AXM-IO32 Module	Online	Analog Input	AI1: 19.794mA	AI2: 10.586mA	
		Digital Input	DI1 Status: <input type="checkbox"/>	DI2 Status: <input type="checkbox"/>	DI3 Status: <input type="checkbox"/> , DI4 Status: <input type="checkbox"/>

Chapter 10: Web Interface Readings and Parameter Settings

SOE:

The SOE webpage will display the Sequence of Event log for the enabled I/O module that is attached to the Acuvim II series meter with timestamps. It will display the DI status for up to 20 events.

The parameters in this webpage are updated every 10 sec.

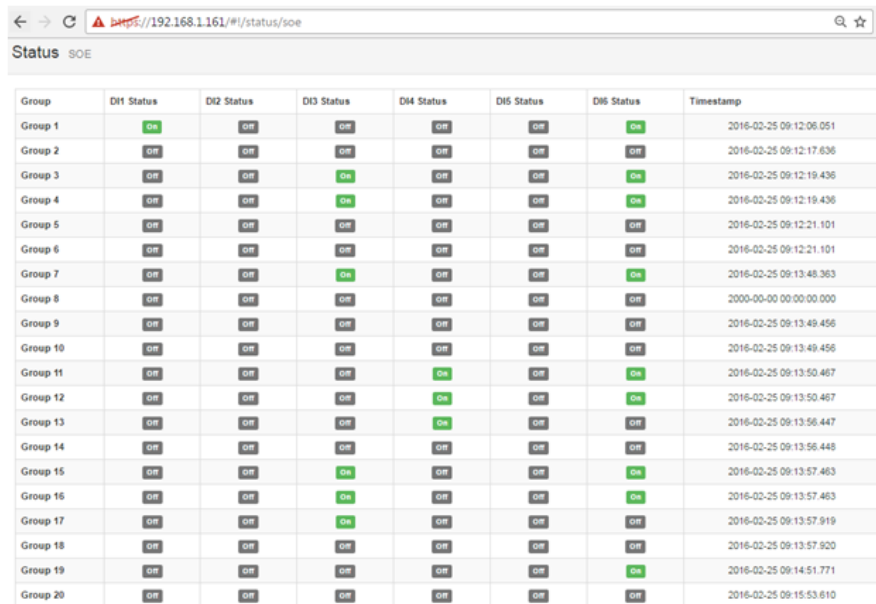

Group	DI1 Status	DI2 Status	DI3 Status	DI4 Status	DI5 Status	DI6 Status	Timestamp
Group 1	OK	OK	OK	OK	OK	OK	2016-02-25 09:12:06.051
Group 2	OK	OK	OK	OK	OK	OK	2016-02-25 09:12:17.636
Group 3	OK	OK	OK	OK	OK	OK	2016-02-25 09:12:19.436
Group 4	OK	OK	OK	OK	OK	OK	2016-02-25 09:12:19.436
Group 5	OK	OK	OK	OK	OK	OK	2016-02-25 09:12:21.101
Group 6	OK	OK	OK	OK	OK	OK	2016-02-25 09:12:21.101
Group 7	OK	OK	OK	OK	OK	OK	2016-02-25 09:13:48.363
Group 8	OK	OK	OK	OK	OK	OK	2000-00-00 00:00:00.000
Group 9	OK	OK	OK	OK	OK	OK	2016-02-25 09:13:49.456
Group 10	OK	OK	OK	OK	OK	OK	2016-02-25 09:13:49.456
Group 11	OK	OK	OK	OK	OK	OK	2016-02-25 09:13:50.467
Group 12	OK	OK	OK	OK	OK	OK	2016-02-25 09:13:50.467
Group 13	OK	OK	OK	OK	OK	OK	2016-02-25 09:13:56.447
Group 14	OK	OK	OK	OK	OK	OK	2016-02-25 09:13:56.448
Group 15	OK	OK	OK	OK	OK	OK	2016-02-25 09:13:57.463
Group 16	OK	OK	OK	OK	OK	OK	2016-02-25 09:13:57.463
Group 17	OK	OK	OK	OK	OK	OK	2016-02-25 09:13:57.919
Group 18	OK	OK	OK	OK	OK	OK	2016-02-25 09:13:57.920
Group 19	OK	OK	OK	OK	OK	OK	2016-02-25 09:14:51.771
Group 20	OK	OK	OK	OK	OK	OK	2016-02-25 09:15:53.610

10.5 Settings web page

Click on the 'Settings' tab to visit the parameter setting web pages that can be configured from the AXM-WEB-PUSH module. There are four parameter settings that can be configured. They are 'Meter', 'Communications', 'Management' and 'Firmware' settings. Each settings webpage will require the AXM-WEB-PUSH module to be rebooted from the Management webpage after any configuration is saved, so the saved changes can take effect.

Acuvim II Series - AXM WEB PUSH

NOTE: The Settings webpage will only be accessible at Admin level.

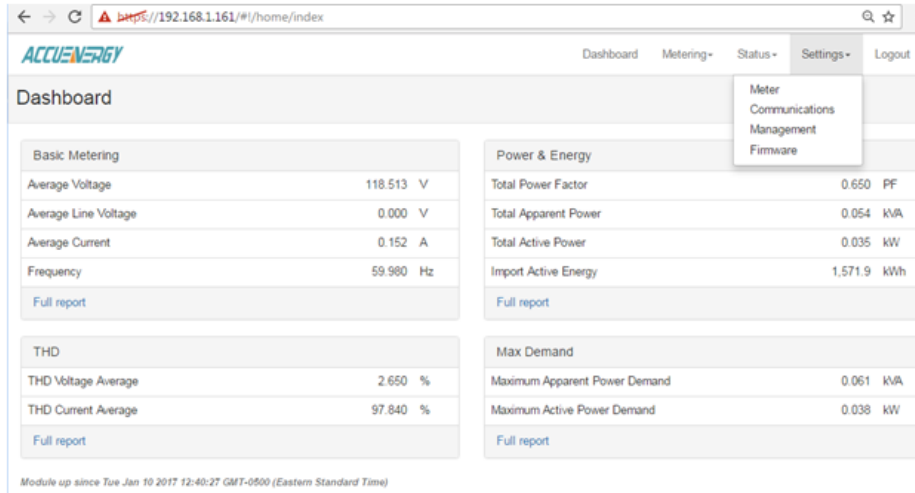

The screenshot shows the AccuEnergy AXM Web Push interface. The browser address bar displays <https://192.168.1.161/#/home/index>. The page title is "Dashboard". The navigation menu includes "Dashboard", "Metering", "Status", "Settings", and "Logout". The "Settings" menu is open, showing options for "Meter", "Communications", "Management", and "Firmware".

Basic Metering

Average Voltage	118.513 V
Average Line Voltage	0.000 V
Average Current	0.152 A
Frequency	59.980 Hz

Power & Energy

Total Power Factor	0.650 PF
Total Apparent Power	0.054 kVA
Total Active Power	0.035 kW
Import Active Energy	1,571.9 kWh

THD

THD Voltage Average	2.650 %
THD Current Average	97.840 %

Max Demand

Maximum Apparent Power Demand	0.061 kVA
Maximum Active Power Demand	0.038 kW

Module up since Tue Jan 10 2017 12:40:27 GMT-0500 (Eastern Standard Time)

Meter Setting:

The meter setting webpage will allow user to configure basic meter settings in order for the meter to measure the voltage and current and display it correctly.

Voltage Wiring: Select how the meter's voltage input terminal is wired by selecting a configuration from the drop down list. I.E. for a three phase three wire configuration without a neutral, select 3LL.

Current Wiring: Select the number of CT's that are connected to the meter's current input terminal by selecting a number from the drop down list.

PT1: Enter the rated input of the potential transformer that is connected to the meter. Possible range is from 50 to 50000V.

CT1: Enter the rated input of the current transformer that is used with the meter. Possible ranges for the CT1 is from 1 to 50000A.

PT2: Enter the rated output of the potential transformer. Possible range is from 50 to 400V.

CT2: Select the rated output of the current transformer from the drop down list. By default this setting is already configured.

Chapter 10: Web Interface Readings and Parameter Settings

Real time Reading: Select the mode of the readings for the meter when it is polled through Modbus. By default the meter is in Secondary mode which will require some parameters to be scaled by a relationship. Configuring the meter in Primary mode does not require any scaling.

I A Direction: Represents the flow of direction for the Phase A current being measured, configure this setting to troubleshoot issues related to incorrect polarity of readings such as real power, Power Factor and etc.

I B Direction: Represents the flow of direction for the Phase B current being measured, configure this setting to troubleshoot issues related to incorrect polarity of readings such as real power, Power Factor and etc.

I C Direction: Represents the flow of direction for the Phase C current being measured, configure this setting to troubleshoot issues related to incorrect polarity of readings such as real power, Power Factor and etc.

Click 'Save' after changing any settings.

The screenshot shows the 'Settings Meter' page in the AccuEnergy web interface. The page includes a navigation bar with 'Dashboard', 'Metering+', 'Status+', 'Settings+', and 'Logout'. The 'Settings Meter' section has a 'Save' button. The configuration options are as follows:

- Voltage Wiring:** 3LN
- Current Wiring:** 3CT
- PT1:** 480.0 (Default 400, Range 50-50,000)
- CT1:** 1600 (Default 5, Range 1-50,000)
- PT2:** 120.0 (Default 400, Range 50-400)
- CT2:** 5A
- Realtime Reading:** Secondary, Primary

Acuvim II Series - AXM WEB PUSH

I A Direction

- Positive
- Negative

I B Direction

- Positive
- Negative

I C Direction

- Positive
- Negative

Communication:

The communication setting webpage will allow the user to configure settings related to the Ethernet network. The functions that the AXM-WEB-PUSH support can be configured from this webpage by selecting the corresponding tab such as Emails, Time/Date , Datalog, HTTP/FTP Post, AcuCloud Post for communicating with the AcuCloud software, SNMP and DNP3.

The screenshot shows the AccuEnergy AXM WEB PUSH interface. At the top, there is a navigation bar with the AccuEnergy logo, a dashboard link, the current date and time (12:41 PM 09/02/21 Feb, 2018), and links for Metering, Status, Settings, and Logout. Below this is a 'Settings' page with a 'Communications' sub-tab and a 'Save' button. The 'Network' tab is selected, showing DHCP settings. The DHCP mode is set to 'Manual'. The IP Address is 192.168.1.163, with a default of 192.168.1.254. The Subnet Mask is 255.255.255.0, with a default of 255.255.255.0. The Gateway is 192.168.1.1, with a default of 192.168.1.1. The DHCP DNS Server 1 is 202.106.0.20, with a default of 8.8.8.8.

Chapter 10: Web Interface Readings and Parameter Settings

Network:

DHCP: Select 'Manual' to manually configure the IP address to access the meter. If set to 'Manual', you'll also need to set the Subnet Mask and Gateway.

Select 'Auto' to have the meter assigned a IP address automatically. With this selection the Subnet Mask, Gateway and DNS servers will also be automatically assigned.

Note: *After changing DHCP to Auto, check the display of the meter to obtain the new IP address that has been assigned after the AXM-WEB-PUSH has completed its reboot and the router has assigned the meter with an IP address.*

IP Address: If the DHCP is configured to Manual, the IP address can be configured from this page.

Subnet Mask: If the DHCP is configured to Manual, the Subnet Mask can be configured from this page.

Gateway: If the DHCP is configured to Manual, the Gateway can be configured from this web page.

DHCP DNS Server 1: Enter the address of the DNS 1 server in this page.

DHCP DNS Server 2: Enter the address of the DNS 2 server in this page.

Allow HTTP: Enable this setting so that the AXM-WEB-PUSH can be accessed through HTTP at port 80.

HTTPS Port: Enter the HTTPS port number of the meter. By default, this setting is configured to 443. The range can be from 6000 to 9999.

Note: *This setting should never be configured to 80.*

Modbus TCP Port: Enter the Modbus port number of the meter. By default, this setting is configured to 502. The range can be from 2000 to 5999.

Proxy Server Enabled: Enable this setting so that the AXM-WEB-PUSH can act as an intermediary to communicate with another server.

Click 'Save' after changing any settings. Users will be prompted to reboot the AXM-WEB-PUSH immediately or later. If later is chosen the AXM-WEB-PUSH will need to be rebooted from the 'Management' page.

Acuvim II Series - AXM WEB PUSH

Emails:

The AXM-WEB-PUSH supports the SMTP protocol so users can setup the email function on the AXM-WEB-PUSH to enable the meter to send emails based on a time interval or when there is an alarm or SOE event or a combination of both. Users must know their SMTP server provider and details regarding their SMTP server, which can be provided by users' IT personal.

There are three modes available for sending emails that the user can enable. The first mode is "Triggered Sending" where emails are sent immediately when there is a new alarm or SOE event. The second mode is "Timed Sending". Users can receive emails at a certain period of time based on the time interval configured and the email will include the data that is selected to be sent. The third mode is when both of the above are enabled.

Users can configure the mail function for their needs by clicking on the 'Settings' tab and selecting 'Communications'. Once redirected to the Communications web page, select 'Email'.

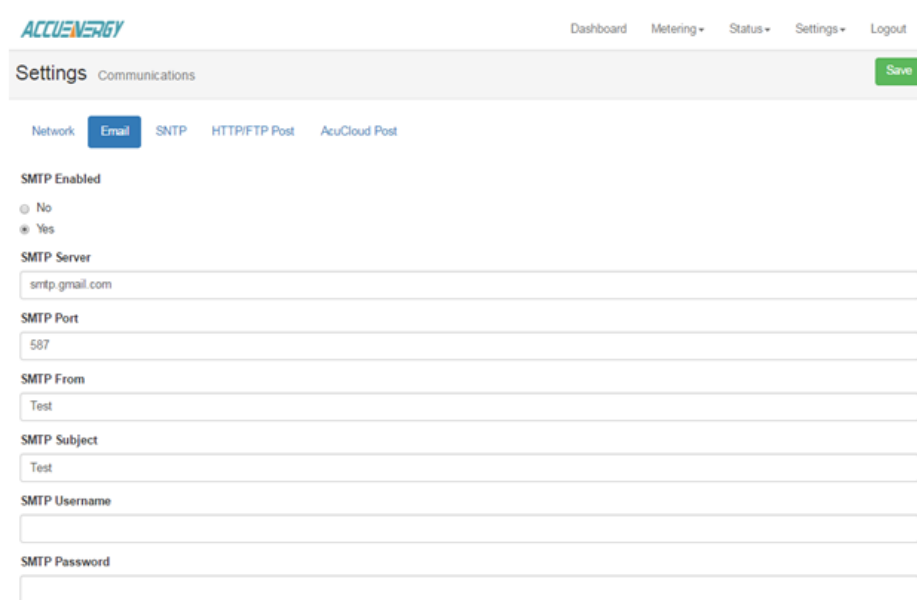

The screenshot displays the AccuEnergy web interface. At the top, the AccuEnergy logo is on the left, and navigation links for Dashboard, Metering, Status, Settings, and Logout are on the right. Below the logo, the page is titled 'Settings' with a sub-tab 'Communications'. A green 'Save' button is visible in the top right corner of the settings area. Under 'Communications', there are four tabs: Network, Email (which is selected and highlighted in blue), SMTP, HTTP/FTP Post, and AcuCloud Post. The 'SMTP Enabled' section has two radio buttons: 'No' and 'Yes', with 'Yes' selected. Below this are several input fields: 'SMTP Server' (containing 'smtp.gmail.com'), 'SMTP Port' (containing '587'), 'SMTP From' (containing 'Test'), 'SMTP Subject' (containing 'Test'), 'SMTP Username' (empty), and 'SMTP Password' (empty).

Chapter 10: Web Interface Readings and Parameter Settings

To use this function the following settings need to be configured:

SMTP Enabled: Select 'Yes' to enable and to further configure the settings related to the SMTP function.

SMTP Server: Enter the URL of a valid SMTP server

SMTP Port: Enter the port number associated with the SMTP server.

SMTP From: Enter a name or phrase which will appear to let you know who the mail is from. I.E. 'Technical Support'

SMTP Username: Enter the SMTP user name for the SMTP server set above.

SMTP Password: Enter the SMTP user password for the user set above.

SMTP To Address 1;2;3: Enter up to three recipients that you wish to have the email sent to in 'SMTP To Address 1', 'SMTP To Address 2' and 'SMTP To Address 3'.

After configuring the above settings, the next step is to select the content for the emails.

To enable emails to be sent based on a new Alarm or SOE Event, select 'Yes' under "SMTP Triggered Sending Alarm Event" or "SMTP Triggered Sending SOE Event".

SMTP Triggered Sending Alarm Event

- No
- Yes

SMTP Triggered Sending SOE Event

- No
- Yes

To receive email reports at timed intervals, configure the following settings:

SMTP Timed Sending Interval: Configure this setting with a value between 5-1440 min. This represents how often the emails will be sent.

To receive emails on specific groups of parameters select 'Yes' under "SMTP Timed Sending xxx"

Acuvim II Series - AXM WEB PUSH

Where xxx can be for receiving emails on:

- **Metering:** Report on Real-time voltage, current, power and etc.
- **Energy:** Report on energy parameters.
- **Harmonics:** Report on the voltage and current harmonics from 2nd to 63rd.
- **Sequence:** Report on the positive, negative and zero components of the voltage and current waveform.
- **Min/Max:** Report on the maximum and minimum statistics that the meter has recorded since the lifetime of the meter or from the last reset of the min/max statistics.
- **Alarm:** Report of the alarm log.
- **SOE Record:** Report of the SOE log.

Click 'Save' after changing any settings. Users will be prompted to reboot the AXM-WEB-PUSH immediately or later. If later is chosen the AXM-WEB-PUSH will need to be rebooted from the 'Management' page.

SMTP Timed Sending Interval

SMTP Timed Sending Metering
 No
 Yes

SMTP Timed Sending Energy
 No
 Yes

SMTP Timed Sending Harmonics
 No
 Yes

SMTP Timed Sending Sequence
 No
 Yes

SMTP Timed Sending Min/Max
 No
 Yes

SMTP Timed Sending Alarms
 No
 Yes

SMTP Timed Sending SOE Record
 No
 Yes

Chapter 10: Web Interface Readings and Parameter Settings

Time/Date:

The device clock of the Acuvim II series meter can be set through the web interface of the AXM-WEB-PUSH module. The AXM-WEB-PUSH module also supports the SNTP (Simple Network Time Protocol) protocol so that the module can update the meter's device clock by synchronizing with a time server.

The AXM-WEB-PUSH can synch with up to 3 time servers. If a time server is down, the module will synchronize with the second or third time server if they are configured.

The settings for the time and date can be found by clicking on the 'Settings' tab and selecting 'Communications'. Click 'Time/Date' to access the webpage.

The screenshot shows the AccuEnergy web interface. At the top, there is a navigation bar with the AccuEnergy logo on the left and links for Dashboard, Metering, Status, Settings, and Logout on the right. Below the navigation bar, there is a 'Settings' section with a 'Communications' sub-tab and a green 'Save' button. Under 'Communications', there are several sub-tabs: Network, Email, Time/Date (which is selected), HTTP/FTP Post, and AcuCloud Post. The 'Time/Date' settings are displayed, including: 'SNTP Enable' with radio buttons for 'No' (selected) and 'Yes'; 'Device Clock' with a text input field showing 'January 4, 2000 4:53 PM' and a calendar icon; and 'Time Zone' with a dropdown menu showing 'USA (Eastern)'. A green 'Save' button is located at the bottom of the settings area.

SNTP Enable: Select 'Yes' to enable the function and to further configure the settings related to the SNTP function.

Device Clock: The device clock of the Acuvim II series can be configured from this setting.

Time Zone: Select the time zone the meter is in or the time zone in which you would like the meter's time to be synchronized to from the drop down list.

SNTP Interval: Enter a number from 1 min to 6000 min to configure how often the meter will synchronize it's time with the time server.

SNTP Server 1;2;3: Enter up to 3 SNTP servers in the "SNTP Server 1", "SNTP Server 2" and "SNTP Server 3" fields.

Acuvim II Series - AXM WEB PUSH

Examples of North American SNTP servers are:

0.us.pool.ntp.org

1.us.pool.ntp.org

2.us.pool.ntp.org

3.us.pool.ntp.org

For more NTP servers based on region, visit the following site:

<http://www.pool.ntp.org/en/>

Click 'Save' after changing any settings. Users will be prompted to reboot the AXM-WEB-PUSH immediately or later. If later is chosen the AXM-WEB-PUSH will need to be rebooted from the 'Management' page.

The screenshot shows the AccuEnergy web interface. At the top, there is a navigation bar with 'Dashboard', 'Metering', 'Status', 'Settings', and 'Logout'. Below this is a 'Settings' section with a 'Communications' sub-section. The 'Time/Date' tab is selected. The 'SNTP Enable' section has 'Yes' selected. The 'SNTP Interval' is set to 5. The 'SNTP Server 1' is set to 0.us.pool.ntp.org. The 'SNTP Server 2' and 'SNTP Server 3' fields are empty. The 'Device Clock' is set to June 26, 2017 3:07 PM. The 'Time Zone' is set to USA (Eastern). A 'Save' button is visible at the bottom left of the form.

Datalog:

The AXM-WEB-PUSH supports logging data onto its memory. Once enabled the module can log up to a day or month of data. The data can be downloaded as a .csv file using a FTP client

The AXM-WEB-PUSH can log data at intervals of time ranging from 15 sec to 1 month.

Chapter 10: Web Interface Readings and Parameter Settings

The screenshot shows the 'Settings' page for 'Communications'. The 'Data Log' tab is active. Under 'Data Upload', the 'Enable' radio button is selected. The 'Log Start Time' is set to 'February 9, 2019 2:57 PM'. The 'Log Interval' is set to '5 minutes'. The 'Backup File Length' is set to '1 day'. The 'Backup File Prefix' is 'logger1'. The 'SFTP Enable' section has the 'Disable' radio button selected. A 'Save' button is located at the bottom left of the form.

Data Upload: To use the data log function to log the data onto the module, select the Enable option to view and configure the settings that are applicable.

Once enabled the following settings related to when the logging of the data will begin, how often the data should be logged, the format and prefix of the file name and how the time stamp will be represented need to be configured:

Log Start Time: Select a valid time for the meter to start logging the data.

Note: The device clock of the meter should be correctly configured and up to date.

Log Interval: Select how frequently the module will log data to the file from the drop down list. The logging interval can be from 15 sec to 1 month.

Backup File Length: Select the length of the log file as either 1 day or 1 month of data from the drop down list.

Backup File Prefix: Provide a name for the log file which will be appended to the beginning of the log file. By default "logger1" will be appended to the beginning of the log file.

SFTP Enable: To download the logged data from the module using a FTP client, select Enable. The log file will then be available to be downloaded using a FTP client using the following credentials:

Acuvim II Series - AXM WEB PUSH

Host: sftp://IPaddressofthemeter

Username: sftpuser

SFTP Password: accuenergy

Port: 22

By default the password for retrieving the backup log files is 'accuenergy'. The user can configure any password or can reset to the default of accuenergy by clicking on the "Reset SFTP Password".

NOTE: After enabling the SFTP function the user must reboot the communication module in order to access the data logs with the default password of 'accuenergy'.

Click 'Save' after changing any settings. Users will be prompted to reboot the AXM-WEB-PUSH immediately or later. If later is chosen the AXM-WEB-PUSH will need to be rebooted from the 'Management' page.

HTTP/FTP Post:

The AXM-WEB-PUSH supports the HTTP and FTP Post functions to send data from the meter to a HTTP/FTP server. The AXM-WEB-PUSH can post .csv files to two different web servers using HTTP Post and can also send the same .csv file to a server using FTP Post.

In the case when there is no connection to the server, the AXM-WEB-PUSH will store the posts and send it out after the connection is restored.

The AXM-WEB-PUSH can post data to a server at intervals of time ranging from 15 sec to 1 month.

The settings for the data log function can be found by clicking on the 'Settings' tab and selecting 'Communications'. Click "Datalog" to access the data log webpage.

The settings for the HTTP/FTP Post function can be found by clicking on the 'Settings' tab and selecting 'Communications'. Click "HTTP/FTP Post" to access the HTTP/FTP Post webpage.

Data Upload: To use the HTTP/FTP post function to send data to the appropriate server, select the Enable option to view and configure the settings that are applicable.

Chapter 10: Web Interface Readings and Parameter Settings

The screenshot shows the 'Settings' page for 'Communications' with a 'Save' button in the top right. The 'HTTP Post' tab is selected. Under 'Data Upload', the 'Enable' radio button is checked. The 'Log Start Time' is set to 'February 9, 2018 2:57 PM'. The 'Log Interval' is set to '5 minutes'. Under 'Timestamp Format', the 'UTC Seconds' radio button is selected. The 'Push File Prefix' is set to 'logger1'. A small example text below reads 'e.g., logger1-2017-10-01T09:45-1day.csv'.

Once enabled the following settings related to when the uploading of the data should begin, how often the data should be logged and uploaded, the format of the file name and how the time stamp will be represented.

Log Start Time: Select a valid time for the meter to start logging the data to be posted.

Note: The device clock of the meter should be correctly configured and up to date.

Log Interval: Select how frequently the meter will log data to the file that will be uploaded to the server from the drop down list. The logging interval can be from 15 sec to 1 month.

Timestamp Format: Select the format of the timestamp for the data that is logged. The format for the timestamp can be based on the Local Time, UTC Seconds or based on ISO8601 Format.

Push File Prefix: Provide a name for the log file which will be appended to the beginning of the log file if "Time Interval Format" is selected as the Post File Name Format. By default "logger1" will be appended to the beginning of the log file.

Post File Length: Select how frequently the log file will be uploaded to the server from the drop down list. The log file length can be from 15 sec to 1 month.

With the above settings configured the following settings need to be configured depending on which protocol will be used:

Acuvim II Series - AXM WEB PUSH

HTTP Push Channel 1 Enable: Select 'Yes' to enable and to further configure the HTTP Push 1 settings.

HTTP Push 1 Meter Upload Url: Enter the Url of the HTTP server that will receive the data from the meter.

HTTP Push 1 Port: Enter the port number for the server that will receive the data.

HTTP Push 1 Password: Enter the password to send data to the receiving server if applicable. Otherwise, leave blank.

HTTP Push 1 Interval: Select how frequently the data should be uploaded to the HTTP server. The data can be posted in intervals from 15 sec to 1 month.

HTTP Push Channel 1 Enable Refresh Changes

No
 Yes

HTTP Push 1 Meter Id

HTTP Push 1 Meter Upload Url

HTTP Push 1 Port
80

HTTP Push 1 Password

HTTP Push 1 Interval
5 minutes

Test HTTP Push 1 Clear HTTP Push 1 Logs

Note: The "TEST HTTP Push1" button should only be utilized after clicking the 'Save' button otherwise a fail response will be observed. If a fail response occurs after clicking 'Save' the settings should be double checked or troubleshooting on the server side may be required.

In the case the network is down and the module cannot send the data to the server it will accumulate all the failed posts and send them out when the network is up. These failed posts can be cleared by clicking the "Clear HTTP Push Logs".

HTTP Push Channel 2 Enable: Select 'Yes' to enable and to further configure the HTTP Push 2 settings.

Chapter 10: Web Interface Readings and Parameter Settings

HTTP Push 2 Meter Upload Url: Enter the Url of the HTTP server that will receive the data from the meter.

HTTP Push 2 Port: Enter the port number for the server that will receive the data.

HTTP Push 2 Password: Enter the password to send data to the receiving server if applicable. Otherwise, leave blank.

HTTP Push 2 Interval: Select how frequently the data should be uploaded to the HTTP server. The data can be posted in intervals from 15 sec to 1 month.

FTP Push Enable: Select 'Yes' to enable and further configure the FTP Push settings.

FTP Push Meter Upload Url: Enter the Url of the FTP server that will receive the data from the meter.

FTP Push Port: Enter the port number for the server that will receive the data.

FTP Push Username: Enter a valid username to send the data to the FTP server. An incorrect username could result in no data being received by the server.

FTP Push Password: Enter a valid password for the username above to send data to the receiving FTP server.

FTP Push Interval: Select how frequently the data should be uploaded to the FTP server. The data can be posted in intervals from 15 sec to 1 month.

Note: The "TEST FTP Push" button should only be utilized after clicking the 'Save' button otherwise a fail response will be observed. If a fail response occurs after clicking 'Save' the settings should be double checked or troubleshooting on the server side may be required.

In the case the network or FTP server is down and the module cannot send the data to the server it will accumulate all the failed posts and send them out when the network is up. These failed posts can be cleared by clicking the "Clear FTP Push Logs".

Click 'Save' after changing any settings. Users will be prompted to reboot the AXM-WEB-PUSH immediately or later. If later is chosen the AXM-WEB-PUSH will need to be rebooted from the 'Management' page.

Acuvim II Series - AXM WEB PUSH

FTP Push Enable
 No
 Yes

FTP Push Uri

FTP Push Port

FTP Push Username

FTP Push Password

FTP Push Interval

AcuCloud Post:

The AXM-WEB-PUSH module can directly interface with the Accuenergy Cloud software AcuCloud. The AXM-WEB-PUSH will post data to the cloud software every five minutes.

AcuCloud will require the serial number of the AXM-WEB-PUSH module which will then provide a token that will be used to configure the AXM-WEB-PUSH so it can send its data to AcuCloud.

The settings for the AcuCloud Post function can be found by clicking on the 'Settings' tab and selecting 'Communications'. Select "AcuCloud Post" to access the settings to configure the AXM-WEB-PUSH to send data to AcuCloud.

AcuCloud Reporting: Select 'Enable' to enable the function and to further configure the settings related to AcuCloud.

AcuCloud URL: The following post URL will be configured by default so that the data can sent to the correct server:

AcuCloud Token: Copy and paste the token provided by the AcuCloud software into this field.

Note: The "TEST AcuCloud" button should only be utilized after clicking the 'Save' button otherwise a fail response will be observed. If a fail response occurs after clicking 'Save' the serial number entered in AcuCloud should be double checked.

Chapter 10: Web Interface Readings and Parameter Settings

Click 'Save' after changing any settings. Users will be prompted to reboot the AXM-WEB-PUSH immediately or later. If later is chosen the AXM-WEB-PUSH will need to be rebooted from the 'Management' page.

In the case the network is down and the module cannot send the data to the server it will accumulate all the failed posts and send them out when the network is up. These failed posts can be cleared by clicking the "Clear AcuCloud Post Logs".

The screenshot shows the 'Settings' page for 'Communications'. The 'AcuCloud Post' tab is selected. Under 'AcuCloud Reporting', the 'Enable' radio button is selected. The 'AcuCloud URL' field contains 'https://acucloud.accuenergy.com/api/v1/devices/newdata/'. The 'Module Serial Number' is 'AM17020045'. The 'AcuCloud Token' field contains 'ed0e7895-f71c-4490-bd9-1631f2e30057'. There are buttons for 'Test AcuCloud', 'Clear AcuCloud Post Logs', and 'Save'.

SNMP:

The AXM-WEB-PUSH module supports the Simple Network Management Protocol(SNMP) protocol for reporting the metering data to the management station. The AXM-WEB-PUSH uses a public community string for read-only access. By default the module will communicate using SNMP port 161. The AXM-WEB-PUSH also supports traps to send unsolicited messages to up to four management stations.

The settings for the SNMP protocol can be found by clicking on the 'Settings' tab and selecting 'Communications'. Select "SNMP" to access the settings to configure the AXM-WEB-PUSH to communicate with a SNMP management station.

SNMP Enable: Select 'Enable' to enable the function and to further configure the settings related to the SNMP protocol.

Read Only Community: By default the community string is Public, this configuration is similar to a password which allows only authorized users to access the meters data.

Acuvim II Series - AXM WEB PUSH

SNMP Port: By default the SNMP Port is configured to 161. The SNMP Port can be any value from 16100 to 16199.

Trap Enable: Select 'Enable' so that the meter will send a message to the management station

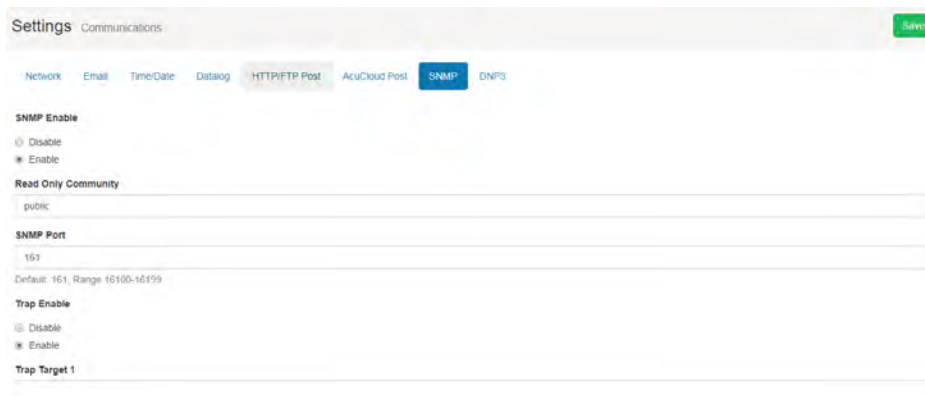

The screenshot shows the 'Settings' page for 'Communications'. The 'SNMP' tab is selected. The configuration includes:

- SNMP Enable:** Radio buttons for 'Disable' and 'Enable' (selected).
- Read Only Community:** Text input field containing 'PUBLIC'.
- SNMP Port:** Text input field containing '161'. Below it, the default is '161' and the range is '16100-16199'.
- Trap Enable:** Radio buttons for 'Disable' and 'Enable' (selected).
- Trap Target 1:** Text input field.

when an event is triggered. The event could be a change in Digital Input Status. The notification can then be sent to upto 4 stations.

Trap Target 1: Enter the IP address and port number of station number 1 that should be notified when there is an event.

Trap Target 2: Enter the IP address and port number of station number 2 that should be notified when there is an event.

Trap Target 3: Enter the IP address and port number of station number 3 that should be notified when there is an event.

Trap Target 4: Enter the IP address and port number of station number 4 that should be notified when there is an event.

Report Buffer Size: Enter the size of the buffer for the amount of notifications will be stored before being sent to the management station. A maximum of 30 notifications can be stored.

Report Hold Time: Enter the time in seconds for how long the notification will be in queue before it gets sent to the management station. By default, this setting is configured to 0 so the notification will be sent immediately after an event occurs. This setting could be configured from 0-30 seconds.

Chapter 10: Web Interface Readings and Parameter Settings

Trap Enable
 Disable
 Enable

Trap Target 1
[Input Field]

Trap Target 2
[Input Field]

Trap Target 3
[Input Field]

Trap Target 4
[Input Field]

Report Buffer Size
30
Range: 0-30

Report Hold Time
0
Range: 0-300

Management:

The Management webpage can be used to reset parameters such as the Demand, Energy, Max/Min, and the alarm records, reboot the web module as well as setting or changing the password for the access levels. The user can also download the network log file for the module from this page which can be used for diagnostics of the module.

This page is where the AXM-WEB-PUSH can be rebooted so that all changes and configurations can take effect. This can be done by clicking on "Reboot Communication Module".

Firmware:

The Firmware webpage is used for updating the firmware version on the AXM-WEB-PUSH module. The user can check if the module they are using is up to date and update the module if needed or they can contact

Acuvim II Series - AXM WEB PUSH

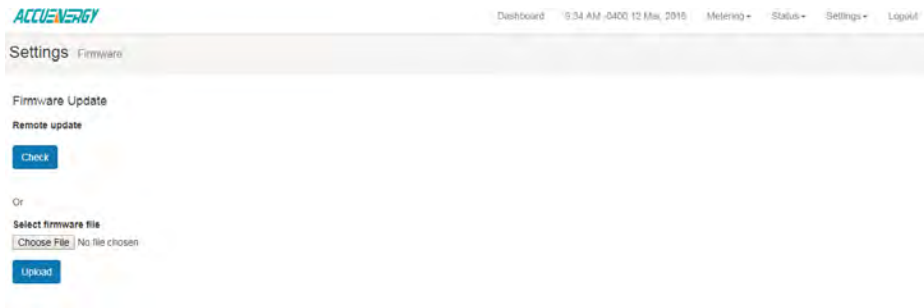

To update the module using the Select Firmware File option:

- Click on "Choose File" and select the firmware file to update from your computer. Then click on 'Upload'.



Once the upload was successfully uploaded you will see the following page confirming that the file was uploaded.

- Click 'Process' to begin the update.

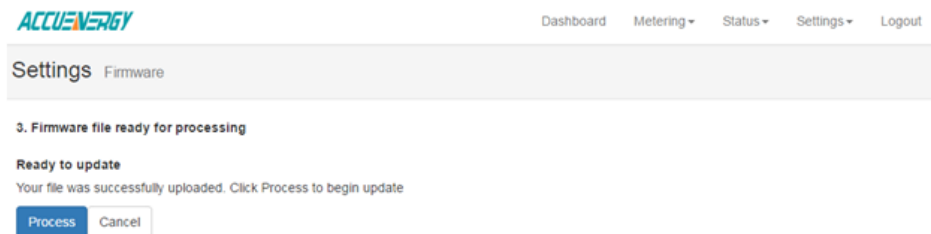

Chapter 10: Web Interface Readings and Parameter Settings

The update will begin and you will see the following message: "Firmware update in progress."

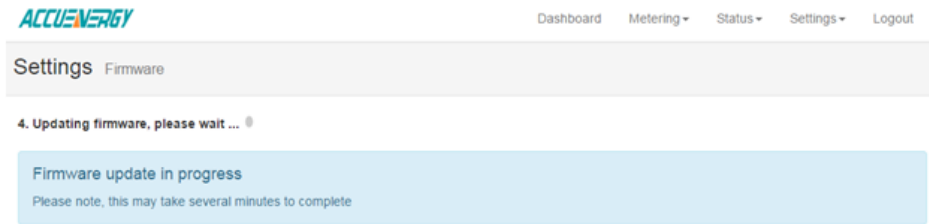

Once the update is complete, you will see the following page.

Note: The module is currently rebooting. This may take 1-2 minutes to complete. When complete, refresh the page to reconnect to the meter. You will be required to log in again.

