

# Shark® 1005

*Electronic Submeter With WiFi Ethernet Capability*



*Installation &  
Operation Manual  
V.1.22  
October 30, 2015*



**Electro Industries/GaugeTech**  
*The Leader In Power Monitoring and Smart Grid Solutions*

---

Shark® 100S Meter Installation and Operation Manual Version 1.2&

Published by:

Electro Industries/GaugeTech

1800 Shames Drive

Westbury, NY 11590

All rights reserved. No part of this publication may be reproduced or transmitted in any form or by any means, electronic or mechanical, including photocopying, recording, or information storage or retrieval systems or any future forms of duplication, for any purpose other than the purchaser's use, without the expressed written permission of Electro Industries/GaugeTech.

© 2015 Electro Industries/GaugeTech

Shark® is a registered trademarks of Electro Industries/GaugeTech. The distinctive shapes, styles and overall appearances of the Shark® meters are trademarks of Electro Industries/GaugeTech. Communicator EXT™ and V-Switch™ key are trademarks of Electro Industries/GaugeTech.

Windows® is either a registered trademark or trademark of Microsoft Corporation in the United States and/or other countries.

Modbus® is a registered trademark of Schneider Electric, licensed to the Modus Organization, Inc.

---

## Customer Service and Support

Customer support is available 9:00 am to 4:30 pm, Eastern Standard Time, Monday through Friday. Please have the model, serial number and a detailed problem description available. If the problem concerns a particular reading, please have all meter readings available. When returning any merchandise to EIG, a return materials authorization number is required. For customer or technical assistance, repair or calibration, phone 516-334-0870 or fax 516-338-4741.

## Product Warranty

Electro Industries/GaugeTech (EIG) warrants all products to be free from defects in material and workmanship for a period of four years from the date of shipment. During the warranty period, we will, at our option, either repair or replace any product that proves to be defective.

To exercise this warranty, fax or call our customer-support department. You will receive prompt assistance and return instructions. Send the instrument, transportation prepaid, to EIG at 1800 Shames Drive, Westbury, NY 11590. Repairs will be made and the instrument will be returned.

This warranty does not apply to defects resulting from unauthorized modification, misuse, or use for any reason other than electrical power monitoring. The Shark<sup>®</sup> 100S meter is not a user-serviceable product.

THIS WARRANTY IS IN LIEU OF ALL OTHER WARRANTIES, EXPRESSED OR IMPLIED, INCLUDING ANY IMPLIED WARRANTY OF MERCHANTABILITY OR FITNESS FOR A PARTICULAR PURPOSE. ELECTRO INDUSTRIES/GAUGETECH SHALL NOT BE LIABLE FOR ANY INDIRECT, SPECIAL OR CONSEQUENTIAL DAMAGES ARISING FROM ANY AUTHORIZED OR UNAUTHORIZED USE OF ANY ELECTRO INDUSTRIES/GAUGETECH PRODUCT. LIABILITY SHALL BE LIMITED TO THE ORIGINAL COST OF THE PRODUCT SOLD.

---

## Use Of Product for Protection

Our products are not to be used for primary over-current protection. Any protection feature in our products is to be used for alarm or secondary protection only.

## Statement of Calibration

Our instruments are inspected and tested in accordance with specifications published by Electro Industries/GaugeTech. The accuracy and a calibration of our instruments are traceable to the National Institute of Standards and Technology through equipment that is calibrated at planned intervals by comparison to certified standards. For optimal performance, EIG recommends that any metering device, including those manufactured by EIG, be verified for accuracy on a yearly interval using NIST traceable accuracy standards.

## Disclaimer

The information presented in this publication has been carefully checked for reliability; however, no responsibility is assumed for inaccuracies. The information contained in this document is subject to change without notice.

## Safety Symbols



In this manual, this symbol indicates that the operator must refer to an important WARNING or CAUTION in the operating instructions. Please see Chapter 4 for important safety information regarding installation and hookup of the meter.

AVERTISSEMENT ou une MISE EN GARDE dans les instructions opérationnelles. Veuillez consulter le chapitre 4 pour des informations importantes relatives à l'installation et branchement du compteur.

The following safety symbols may be used on the meter itself:

Les symboles de sécurité suivante peuvent être utilisés sur le compteur même:



This symbol alerts you to the presence of high voltage, which can cause dangerous electrical shock.

Ce symbole vous indique la présence d'une haute tension qui peut provoquer une décharge électrique dangereuse.



This symbol indicates the field wiring terminal that must be connected to earth ground before operating the meter, which protects against electrical shock in case of a fault condition.

---

Ce symbole indique que la borne de pose des canalisations in-situ qui doit être branchée dans la mise à terre avant de faire fonctionner le compteur qui est protégé contre une décharge électrique ou un état défectueux.



This symbol indicates that the user must refer to this manual for specific WARNING or CAUTION information to avoid personal injury or damage to the product.

Ce symbole indique que l'utilisateur doit se référer à ce manuel pour AVERTISSEMENT ou MISE EN GARDE l'information pour éviter toute blessure ou tout endommagement du produit.

## FCC Information

Regarding the wireless module:

- This device complies with Part 15 of the FCC rules. Operation is subject to the following two conditions: 1) this device may not cause harmful interference, and 2) this device must accept any interference received, including interference that may cause undesired operation.
- The antenna provided must not be replaced with an different type. Attaching a different antenna will void the FCC approval and the FCC ID can no longer be considered.

---

## About Electro Industries/GaugeTech

Founded in 1975 by engineer and inventor Dr. Samuel Kagan, Electro Industries/GaugeTech changed the face of power monitoring forever with its first breakthrough innovation: an affordable, easy-to-use AC power meter.

Forty years since its founding, Electro Industries/GaugeTech, the leader in power monitoring and control, continues to revolutionize the industry with the highest quality, cutting edge power monitoring and control technology on the market today. An ISO 9001:2008 certified company, EIG sets the industry standard for advanced power quality and reporting, revenue metering and substation data acquisition and control. EIG products can be found on site at mainly all of today's leading manufacturers, industrial giants and utilities.

EIG products are primarily designed, manufactured, tested and calibrated at our facility in Westbury, New York.

# Table of Contents

Customer Service and Support	iii
Product Warranty	iii
Use Of Product for Protection	iv
Statement of Calibration	iv
Disclaimer	iv
Safety Symbols	iv
FCC Information	v
About Electro Industries/GaugeTech (EIG)	vi
<b>11: Three-Phase Power Measurement</b>	<b>1-1</b>
1.1: Three-Phase System Configurations	1-1
1.1.1: Wye Connection	1-1
1.1.2: Delta Connection	1-4
1.1.3: Blondel's Theorem and Three Phase Measurement	1-6
1.2: Power, Energy and Demand	1-8
1.3: Reactive Energy and Power Factor	1-12
1.4: Harmonic Distortion	1-14
1.5: Power Quality	1-17
<b>2: Shark® 100S Submeter Overview and Specifications</b>	<b>2-1</b>
2.1: Hardware Overview	2-1
2.1.1: Model Number plus Option Numbers	2-3
2.1.2: V-Switch™ Technology	2-3
2.1.3: Measured Values	2-4



2.1.4: Utility Peak Demand	2-5
2.2: Specifications	2-5
2.3: Compliance	2-10
2.4: Accuracy	2-10
<b>3: Mechanical Installation</b>	<b>3-1</b>
3.1: Overview	3-1
3.2: Install the Base	3-2
3.2.1: Mounting Diagrams	3-3
3.3: Secure the Cover	3-7
<b>4: Electrical Installation</b>	<b>4-1</b>
4.1: Considerations When Installing Meters	4-1
4.2: Electrical Connections	4-4
4.3: Ground Connections	4-5
4.4: Voltage Fuses	4-5
4.5: Electrical Connection Diagrams	4-6
4.6: Extended Surge Protection for Substation Instrumentation	4-20
<b>5: Communication Installation</b>	<b>5-1</b>
5.1: Shark® 100S Communication	5-1
5.1.1: IrDA Port (Com 1)	5-1
5.1.1.1: USB to IrDA Adapter	5-2
5.1.2: RS485 Communication Com 2 (485 Option)	5-3
5.1.3: KYZ Output	5-6
5.1.4: Ethernet Connection	5-8



5.2: Meter Communication and Programming Overview	5-10
5.2.1: How to Connect to the Submeter	5-11
5.2.2: Shark® 100S Submeter Device Profile Settings	5-14
<b>6: Ethernet Configuration</b>	<b>6-1</b>
6.1: Introduction	6-1
6.2: Factory Default Settings	6-2
6.2.1: Modbus/TCP to RTU Bridge Setup	6-3
6.3: Configure Network Module	6-4
6.3.1: Configuration Requirements	6-4
6.3.2: Configuring the Ethernet Adapter	6-5
6.3.3: Detailed Configuration Parameters	6-8
6.3.4: Setup Details	6-9
6.4: Network Module Hardware Initialization	6-14
<b>7: Using the Submeter</b>	<b>7-1</b>
7.1: Introduction	7-1
7.1.1: Understanding Submeter Face Elements	7-1
7.1.2: Understanding Submeter Face Buttons	7-2
7.2: Using the Front Panel	7-3
7.2.1: Understanding Startup and Default Displays	7-3
7.2.2: Using the Main Menu	7-4
7.2.3: Using Reset Mode	7-5
7.2.4: Entering a Password	7-6
7.2.5: Using Configuration Mode	7-7

---

7.2.5.1: Configuring the Scroll Feature	7-9
7.2.5.2: Configuring CT Setting	7-10
7.2.5.3: Configuring PT Setting	7-11
7.2.5.4: Configuring Connection Setting	7-13
7.2.5.5: Configuring Communication Port Setting	7-13
7.2.6: Using Operating Mode	7-15
7.3: Understanding the % of Load Bar	7-16
7.4: Performing Watt-Hour Accuracy Testing (Verification)	7-17
7.5: Upgrade the Submeter Using V-Switch™ Key Technology	7-19
<b>A: Shark® 100S Meter Navigation Maps</b>	<b>A-1</b>
A.1: Introduction	A-1
A.2: Navigation Maps (Sheets 1 to 4)	A-1
B: Shark® 100S Meter Modbus Map	A-1
<b>B.1: Introduction</b>	<b>B-1</b>
B.2: Modbus Register Map Sections	B-1
B.3: Data Formats	B-1
B.4: Floating Point Values	B-2
B.5: Modbus Register Map	B-3
<b>C: Shark® 100S Meter DNP Map</b>	<b>C-1</b>
C.1: Introduction	C-1
C.2: DNP Mapping (DNP-1 to DNP-2)	C-1
<b>D: DNP 3.0 Protocol Assignments</b>	<b>D-1</b>
D.1: DNP Implementation	D-1

D.2: Data Link Layer	D-2
D.3: Transport Layer	D-3
D.4: Application Layer	D-3
D.4.1: Object and Variation	D-4
D.4.1.1: Binary Output Status (Obj. 10, Var. 2)	D-5
D.4.1.2: Control Relay Output Block (Obj. 12, Var. 1)	D-6
D.4.1.3: 32-Bit Binary Counter Without Flag (Obj. 20, Var. 5)	D-7
D.4.1.4: 16-Bit Analog Input Without Flag (Obj. 30, Var. 4)	D-7
D.4.1.5: Class 0 Data (Obj. 60, Var. 1)	D-13
D.4.1.6: Internal Indications (Obj. 80, Var. 1)	D-13
<b>E: Using the USB to IrDA Adapter CAB6490</b>	<b>E-1</b>
E.1: Introduction	E-1
E.2: Installation Procedures	E-1

# 1: Three-Phase Power Measurement

This introduction to three-phase power and power measurement is intended to provide only a brief overview of the subject. The professional meter engineer or meter technician should refer to more advanced documents such as the EEI Handbook for Electricity Metering and the application standards for more in-depth and technical coverage of the subject.

## 1.1: Three-Phase System Configurations

Three-phase power is most commonly used in situations where large amounts of power will be used because it is a more effective way to transmit the power and because it provides a smoother delivery of power to the end load. There are two commonly used connections for three-phase power, a wye connection or a delta connection. Each connection has several different manifestations in actual use.

When attempting to determine the type of connection in use, it is a good practice to follow the circuit back to the transformer that is serving the circuit. It is often not possible to conclusively determine the correct circuit connection simply by counting the wires in the service or checking voltages. Checking the transformer connection will provide conclusive evidence of the circuit connection and the relationships between the phase voltages and ground.

### 1.1.1: Wye Connection

The wye connection is so called because when you look at the phase relationships and the winding relationships between the phases it looks like a Y. Figure 1.1 depicts the winding relationships for a wye-connected service. In a wye service the neutral (or center point of the wye) is typically grounded. This leads to common voltages of 208/120 and 480/277 (where the first number represents the phase-to-phase voltage and the second number represents the phase-to-ground voltage).

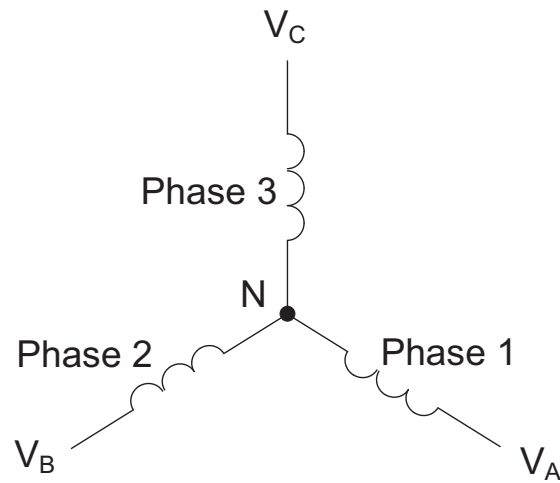

Figure 1.1: Three-phase Wye Winding

The three voltages are separated by  $120^\circ$  electrically. Under balanced load conditions the currents are also separated by  $120^\circ$ . However, unbalanced loads and other conditions can cause the currents to depart from the ideal  $120^\circ$  separation. Three-phase voltages and currents are usually represented with a phasor diagram. A phasor diagram for the typical connected voltages and currents is shown in Figure 1.2.

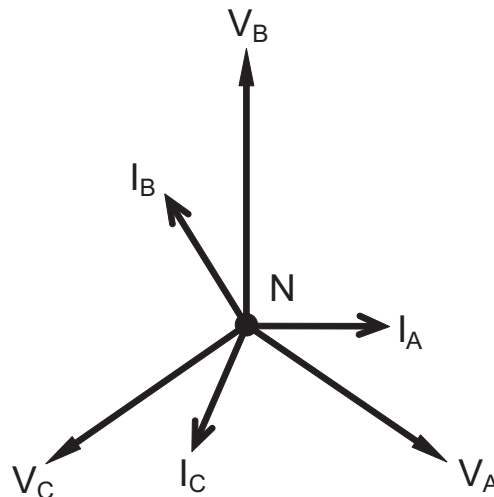

Figure 1.2: Phasor Diagram Showing Three-phase Voltages and Currents

The phasor diagram shows the  $120^\circ$  angular separation between the phase voltages. The phase-to-phase voltage in a balanced three-phase wye system is 1.732 times the phase-to-neutral voltage. The center point of the wye is tied together and is typically grounded. Table 1.1 shows the common voltages used in the United States for wye-connected systems.

Phase to Ground Voltage	Phase to Phase Voltage
120 volts	208 volts
277 volts	480 volts
2,400 volts	4,160 volts
7,200 volts	12,470 volts
7,620 volts	13,200 volts

Table 1: Common Phase Voltages on Wye Services

Usually a wye-connected service will have four wires: three wires for the phases and one for the neutral. The three-phase wires connect to the three phases (as shown in Figure 1.1). The neutral wire is typically tied to the ground or center point of the wye.

In many industrial applications the facility will be fed with a four-wire wye service but only three wires will be run to individual loads. The load is then often referred to as a delta-connected load but the service to the facility is still a wye service; it contains four wires if you trace the circuit back to its source (usually a transformer). In this type of connection the phase to ground voltage will be the phase-to-ground voltage indicated in Table 1, even though a neutral or ground wire is not physically present at the load. The transformer is the best place to determine the circuit connection type because this is a location where the voltage reference to ground can be conclusively identified.

### 1.1.2: Delta Connection

Delta-connected services may be fed with either three wires or four wires. In a three-phase delta service the load windings are connected from phase-to-phase rather than from phase-to-ground. Figure 1.3 shows the physical load connections for a delta service.

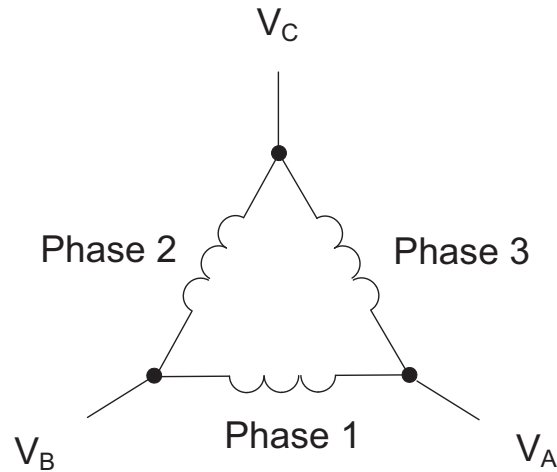

Figure 1.3: Three-phase Delta Winding Relationship

In this example of a delta service, three wires will transmit the power to the load. In a true delta service, the phase-to-ground voltage will usually not be balanced because the ground is not at the center of the delta.

Figure 1.4 shows the phasor relationships between voltage and current on a three-phase delta circuit.

In many delta services, one corner of the delta is grounded. This means the phase to ground voltage will be zero for one phase and will be full phase-to-phase voltage for the other two phases. This is done for protective purposes.



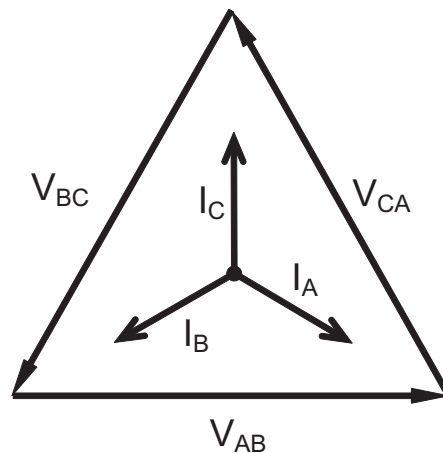

Figure 1.4: Phasor Diagram, Three-Phase Voltages and Currents, Delta-Connected

Another common delta connection is the four-wire, grounded delta used for lighting loads. In this connection the center point of one winding is grounded. On a 120/240 volt, four-wire, grounded delta service the phase-to-ground voltage would be 120 volts on two phases and 208 volts on the third phase. Figure 1.5 shows the phasor diagram for the voltages in a three-phase, four-wire delta system.

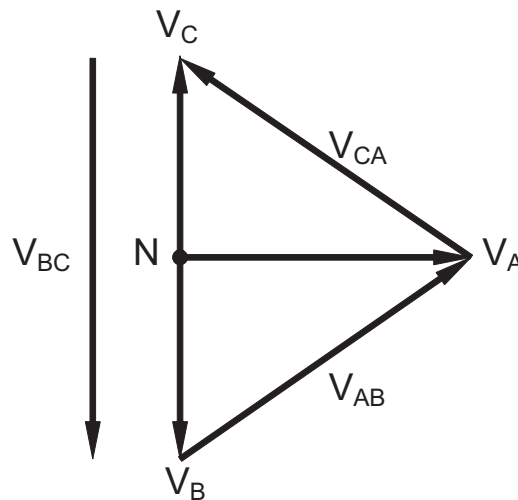

Figure 1.5: Phasor Diagram Showing Three-phase Four-Wire Delta-Connected System

### 1.1.3: Blondel's Theorem and Three Phase Measurement

In 1893 an engineer and mathematician named Andre E. Blondel set forth the first scientific basis for polyphase metering. His theorem states:

If energy is supplied to any system of conductors through N wires, the total power in the system is given by the algebraic sum of the readings of N wattmeters so arranged that each of the N wires contains one current coil, the corresponding potential coil being connected between that wire and some common point. If this common point is on one of the N wires, the measurement may be made by the use of N-1 wattmeters.

The theorem may be stated more simply, in modern language:

In a system of N conductors, N-1 meter elements will measure the power or energy taken provided that all the potential coils have a common tie to the conductor in which there is no current coil.

Three-phase power measurement is accomplished by measuring the three individual phases and adding them together to obtain the total three phase value. In older analog meters, this measurement was accomplished using up to three separate elements. Each element combined the single-phase voltage and current to produce a torque on the meter disk. All three elements were arranged around the disk so that the disk was subjected to the combined torque of the three elements. As a result the disk would turn at a higher speed and register power supplied by each of the three wires.

According to Blondel's Theorem, it was possible to reduce the number of elements under certain conditions. For example, a three-phase, three-wire delta system could be correctly measured with two elements (two potential coils and two current coils) if the potential coils were connected between the three phases with one phase in common.

In a three-phase, four-wire wye system it is necessary to use three elements. Three voltage coils are connected between the three phases and the common neutral conductor. A current coil is required in each of the three phases.

In modern digital meters, Blondel's Theorem is still applied to obtain proper metering. The difference in modern meters is that the digital meter measures each phase voltage and current and calculates the single-phase power for each phase. The meter then sums the three phase powers to a single three-phase reading.

Some digital meters measure the individual phase power values one phase at a time. This means the meter samples the voltage and current on one phase and calculates a power value. Then it samples the second phase and calculates the power for the second phase. Finally, it samples the third phase and calculates that phase power. After sampling all three phases, the meter adds the three readings to create the equivalent three-phase power value. Using mathematical averaging techniques, this method can derive a quite accurate measurement of three-phase power.

More advanced meters actually sample all three phases of voltage and current simultaneously and calculate the individual phase and three-phase power values. The advantage of simultaneous sampling is the reduction of error introduced due to the difference in time when the samples were taken.

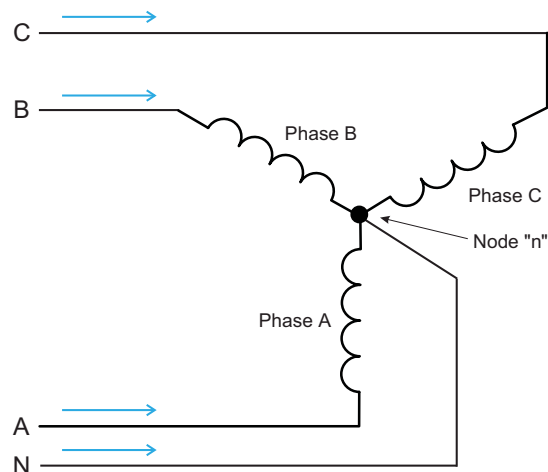

Figure 1.6: Three-Phase Wye Load Illustrating Kirchhoff's Law and Blondel's Theorem

Blondel's Theorem is a derivation that results from Kirchhoff's Law. Kirchhoff's Law states that the sum of the currents into a node is zero. Another way of stating the same thing is that the current into a node (connection point) must equal the current out of the node. The law can be applied to measuring three-phase loads. Figure 1.6 shows a typical connection of a three-phase load applied to a three-phase, four-wire service. Kirchhoff's Law holds that the sum of currents A, B, C and N must equal zero or that the sum of currents into Node "n" must equal zero.

If we measure the currents in wires A, B and C, we then know the current in wire N by Kirchhoff's Law and it is not necessary to measure it. This fact leads us to the conclusion of Blondel's Theorem- that we only need to measure the power in three of

the four wires if they are connected by a common node. In the circuit of Figure 1.6 we must measure the power flow in three wires. This will require three voltage coils and three current coils (a three-element meter). Similar figures and conclusions could be reached for other circuit configurations involving Delta-connected loads.

## 1.2: Power, Energy and Demand

It is quite common to exchange power, energy and demand without differentiating between the three. Because this practice can lead to confusion, the differences between these three measurements will be discussed.

Power is an instantaneous reading. The power reading provided by a meter is the present flow of watts. Power is measured immediately just like current. In many digital meters, the power value is actually measured and calculated over a one second interval because it takes some amount of time to calculate the RMS values of voltage and current. But this time interval is kept small to preserve the instantaneous nature of power.

Energy is always based on some time increment; it is the integration of power over a defined time increment. Energy is an important value because almost all electric bills are based, in part, on the amount of energy used.

Typically, electrical energy is measured in units of kilowatt-hours (kWh). A kilowatt-hour represents a constant load of one thousand watts (one kilowatt) for one hour. Stated another way, if the power delivered (instantaneous watts) is measured as 1,000 watts and the load was served for a one hour time interval then the load would have absorbed one kilowatt-hour of energy. A different load may have a constant power requirement of 4,000 watts. If the load were served for one hour it would absorb four kWh. If the load were served for 15 minutes it would absorb  $\frac{1}{4}$  of that total or one kWh.

Figure 1.7 shows a graph of power and the resulting energy that would be transmitted as a result of the illustrated power values. For this illustration, it is assumed that the power level is held constant for each minute when a measurement is taken. Each bar in the graph will represent the power load for the one-minute increment of time. In real life the power value moves almost constantly.

The data from Figure 1.7 is reproduced in Table 2 to illustrate the calculation of energy. Since the time increment of the measurement is one minute and since we

specified that the load is constant over that minute, we can convert the power reading to an equivalent consumed energy reading by multiplying the power reading times 1/60 (converting the time base from minutes to hours).

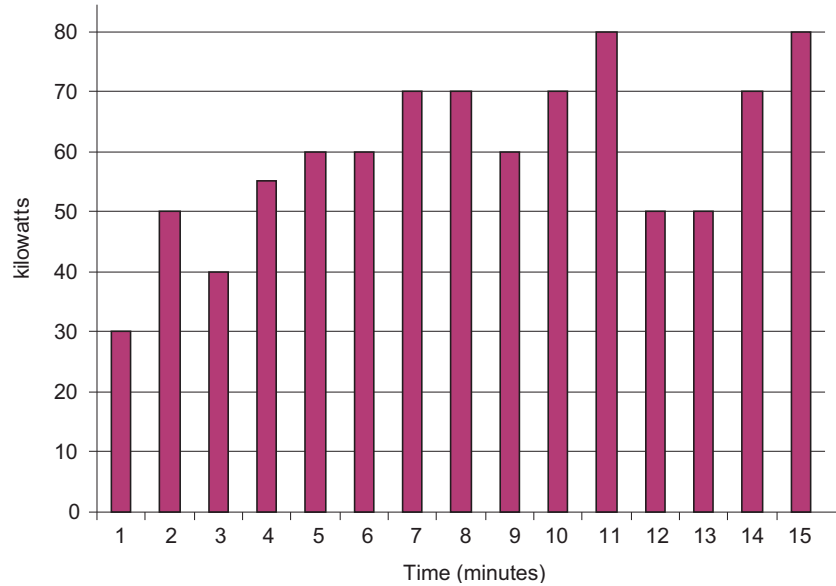

Figure 1.7: Power Use over Time

Time Interval (minute)	Power (kW)	Energy (kWh)	Accumulated Energy (kWh)
1	30	0.50	0.50
2	50	0.83	1.33
3	40	0.67	2.00
4	55	0.92	2.92
5	60	1.00	3.92
6	60	1.00	4.92
7	70	1.17	6.09
8	70	1.17	7.26
9	60	1.00	8.26
10	70	1.17	9.43
11	80	1.33	10.76
12	50	0.83	12.42
13	50	0.83	12.42
14	70	1.17	13.59
15	80	1.33	14.92

Table 1.2: Power and Energy Relationship over Time

As in Table 1.2, the accumulated energy for the power load profile of Figure 1.7 is 14.92 kWh.

Demand is also a time-based value. The demand is the average rate of energy use over time. The actual label for demand is kilowatt-hours/hour but this is normally reduced to kilowatts. This makes it easy to confuse demand with power, but demand is not an instantaneous value. To calculate demand it is necessary to accumulate the energy readings (as illustrated in Figure 1.7) and adjust the energy reading to an hourly value that constitutes the demand.

In the example, the accumulated energy is 14.92 kWh. But this measurement was made over a 15-minute interval. To convert the reading to a demand value, it must be normalized to a 60-minute interval. If the pattern were repeated for an additional three 15-minute intervals the total energy would be four times the measured value or

59.68 kWh. The same process is applied to calculate the 15-minute demand value. The demand value associated with the example load is 59.68 kWh/hr or 59.68 kWd. Note that the peak instantaneous value of power is 80 kW, significantly more than the demand value.

Figure 1.8 shows another example of energy and demand. In this case, each bar represents the energy consumed in a 15-minute interval. The energy use in each interval typically falls between 50 and 70 kWh. However, during two intervals the energy rises sharply and peaks at 100 kWh in interval number 7. This peak of usage will result in setting a high demand reading. For each interval shown the demand value would be four times the indicated energy reading. So interval 1 would have an associated demand of 240 kWh/hr. Interval 7 will have a demand value of 400 kWh/hr. In the data shown, this is the peak demand value and would be the number that would set the demand charge on the utility bill.

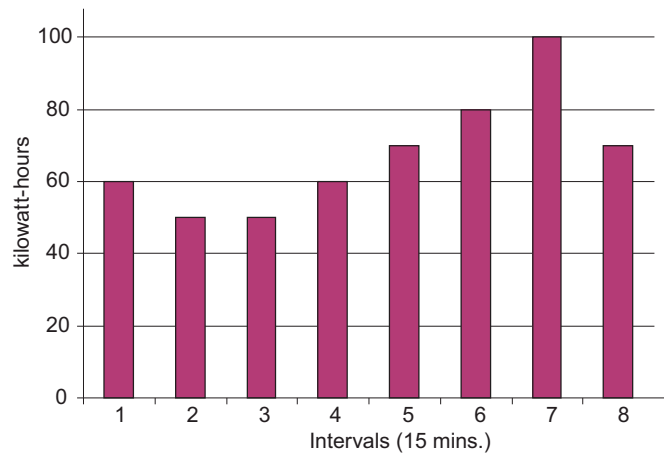

Figure 1.8: Energy Use and Demand

As can be seen from this example, it is important to recognize the relationships between power, energy and demand in order to control loads effectively or to monitor use correctly.



### 1.3: Reactive Energy and Power Factor

The real power and energy measurements discussed in the previous section relate to the quantities that are most used in electrical systems. But it is often not sufficient to only measure real power and energy. Reactive power is a critical component of the total power picture because almost all real-life applications have an impact on reactive power. Reactive power and power factor concepts relate to both load and generation applications. However, this discussion will be limited to analysis of reactive power and power factor as they relate to loads. To simplify the discussion, generation will not be considered.

Real power (and energy) is the component of power that is the combination of the voltage and the value of corresponding current that is directly in phase with the voltage. However, in actual practice the total current is almost never in phase with the voltage. Since the current is not in phase with the voltage, it is necessary to consider both the in-phase component and the component that is at quadrature (angularly rotated  $90^\circ$  or perpendicular) to the voltage. Figure 1.9 shows a single-phase voltage and current and breaks the current into its in-phase and quadrature components.

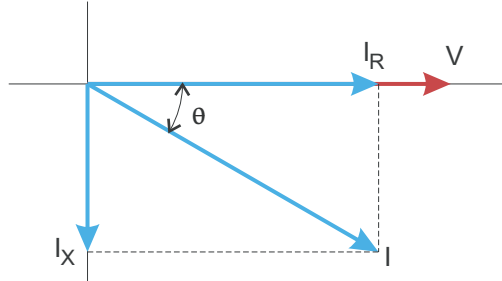

Figure 1.9: Voltage and Complex Current

The voltage ( $V$ ) and the total current ( $I$ ) can be combined to calculate the apparent power or VA. The voltage and the in-phase current ( $I_R$ ) are combined to produce the real power or watts. The voltage and the quadrature current ( $I_X$ ) are combined to calculate the reactive power.

The quadrature current may be lagging the voltage (as shown in Figure 1.9) or it may lead the voltage. When the quadrature current lags the voltage the load is requiring both real power (watts) and reactive power (VARs). When the quadrature current

leads the voltage the load is requiring real power (watts) but is delivering reactive power (VARs) back into the system; that is VARs are flowing in the opposite direction of the real power flow.

Reactive power (VARs) is required in all power systems. Any equipment that uses magnetization to operate requires VARs. Usually the magnitude of VARs is relatively low compared to the real power quantities. Utilities have an interest in maintaining VAR requirements at the customer to a low value in order to maximize the return on plant invested to deliver energy. When lines are carrying VARs, they cannot carry as many watts. So keeping the VAR content low allows a line to carry its full capacity of watts. In order to encourage customers to keep VAR requirements low, some utilities impose a penalty if the VAR content of the load rises above a specified value.

A common method of measuring reactive power requirements is power factor. Power factor can be defined in two different ways. The more common method of calculating power factor is the ratio of the real power to the apparent power. This relationship is expressed in the following formula:

$$\text{Total PF} = \text{real power} / \text{apparent power} = \text{watts/VA}$$

This formula calculates a power factor quantity known as Total Power Factor. It is called Total PF because it is based on the ratios of the power delivered. The delivered power quantities will include the impacts of any existing harmonic content. If the voltage or current includes high levels of harmonic distortion the power values will be affected. By calculating power factor from the power values, the power factor will include the impact of harmonic distortion. In many cases this is the preferred method of calculation because the entire impact of the actual voltage and current are included.

A second type of power factor is Displacement Power Factor. Displacement PF is based on the angular relationship between the voltage and current. Displacement power factor does not consider the magnitudes of voltage, current or power. It is solely based on the phase angle differences. As a result, it does not include the impact of

harmonic distortion. Displacement power factor is calculated using the following equation:

$$\text{Displacement PF} = \cos\theta$$

where  $\theta$  is the angle between the voltage and the current (see Fig. 1.9).

In applications where the voltage and current are not distorted, the Total Power Factor will equal the Displacement Power Factor. But if harmonic distortion is present, the two power factors will not be equal.

#### 1.4: Harmonic Distortion

Harmonic distortion is primarily the result of high concentrations of non-linear loads. Devices such as computer power supplies, variable speed drives and fluorescent light ballasts make current demands that do not match the sinusoidal waveform of AC electricity. As a result, the current waveform feeding these loads is periodic but not sinusoidal. Figure 1.10 shows a normal, sinusoidal current waveform. This example has no distortion.

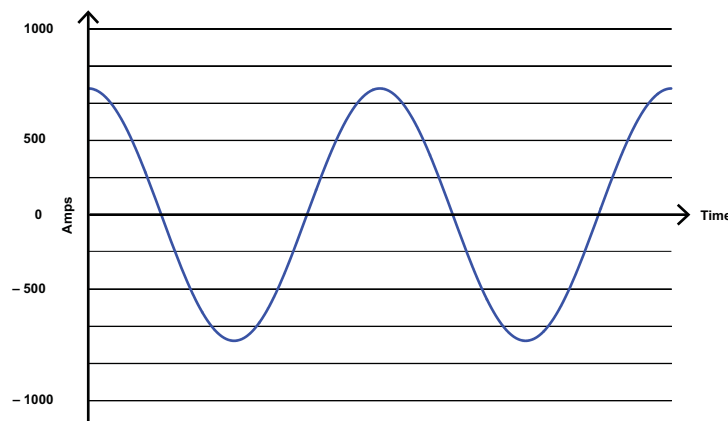

Figure 1.10: Nondistorted Current Waveform

Figure 1.11 shows a current waveform with a slight amount of harmonic distortion. The waveform is still periodic and is fluctuating at the normal 60 Hz frequency. However, the waveform is not a smooth sinusoidal form as seen in Figure 1.10.

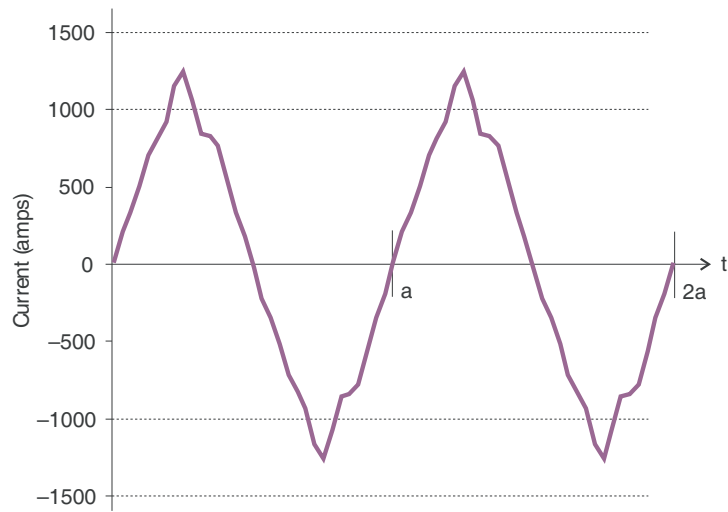

Figure 1.11: Distorted Current Waveform

The distortion observed in Figure 1.11 can be modeled as the sum of several sinusoidal waveforms of frequencies that are multiples of the fundamental 60 Hz frequency. This modeling is performed by mathematically disassembling the distorted waveform into a collection of higher frequency waveforms.

These higher frequency waveforms are referred to as harmonics. Figure 1.12 shows the content of the harmonic frequencies that make up the distortion portion of the waveform in Figure 1.11.

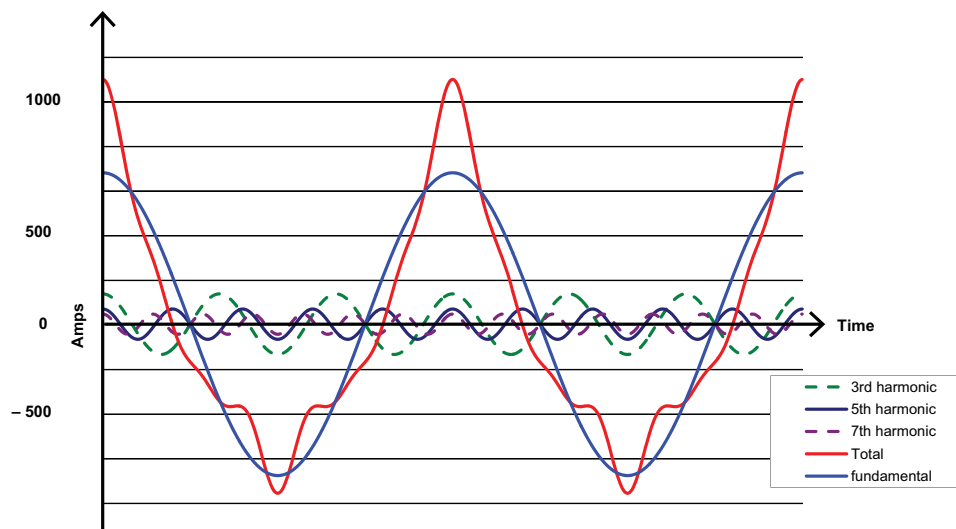

Figure 1.12: Waveforms of the Harmonics

The waveforms shown in Figure 1.12 are not smoothed but do provide an indication of the impact of combining multiple harmonic frequencies together.

When harmonics are present it is important to remember that these quantities are operating at higher frequencies. Therefore, they do not always respond in the same manner as 60 Hz values.

Inductive and capacitive impedance are present in all power systems. We are accustomed to thinking about these impedances as they perform at 60 Hz. However, these impedances are subject to frequency variation.

$$X_L = j\omega L \quad \text{and}$$

$$X_C = 1/j\omega C$$

At 60 Hz,  $\omega = 377$ ; but at 300 Hz (5th harmonic)  $\omega = 1,885$ . As frequency changes impedance changes and system impedance characteristics that are normal at 60 Hz may behave entirely differently in the presence of higher order harmonic waveforms.

Traditionally, the most common harmonics have been the low order, odd frequencies, such as the 3rd, 5th, 7th, and 9th. However newer, non-linear loads are introducing significant quantities of higher order harmonics.

Since much voltage monitoring and almost all current monitoring is performed using instrument transformers, the higher order harmonics are often not visible. Instrument transformers are designed to pass 60 Hz quantities with high accuracy. These devices, when designed for accuracy at low frequency, do not pass high frequencies with high accuracy; at frequencies above about 1200 Hz they pass almost no information. So when instrument transformers are used, they effectively filter out higher frequency harmonic distortion making it impossible to see.

However, when monitors can be connected directly to the measured circuit (such as direct connection to a 480 volt bus) the user may often see higher order harmonic distortion. An important rule in any harmonics study is to evaluate the type of equipment and connections before drawing a conclusion. Not being able to see harmonic distortion is not the same as not having harmonic distortion.

It is common in advanced meters to perform a function commonly referred to as waveform capture. Waveform capture is the ability of a meter to capture a present picture of the voltage or current waveform for viewing and harmonic analysis.

Typically a waveform capture will be one or two cycles in duration and can be viewed as the actual waveform, as a spectral view of the harmonic content, or a tabular view showing the magnitude and phase shift of each harmonic value. Data collected with waveform capture is typically not saved to memory. Waveform capture is a real-time data collection event.

Waveform capture should not be confused with waveform recording that is used to record multiple cycles of all voltage and current waveforms in response to a transient condition.

### 1.5: Power Quality

Power quality can mean several different things. The terms "power quality" and "power quality problem" have been applied to all types of conditions. A simple definition of "power quality problem" is any voltage, current or frequency deviation that results in mis-operation or failure of customer equipment or systems. The causes of power quality problems vary widely and may originate in the customer equipment, in an adjacent customer facility or with the utility.

In his book Power Quality Primer, Barry Kennedy provided information on different types of power quality problems. Some of that information is summarized in Table 1.3.

Cause	Disturbance Type	Source
Impulse transient	Transient voltage disturbance, sub-cycle duration	Lightning Electrostatic discharge Load switching Capacitor switching
Oscillatory transient with decay	Transient voltage, sub-cycle duration	Line/cable switching Capacitor switching Load switching
Sag/swell	RMS voltage, multiple cycle duration	Remote system faults
Interruptions	RMS voltage, multiple seconds or longer duration	System protection Circuit breakers Fuses Maintenance
Under voltage/over voltage	RMS voltage, steady state, multiple seconds or longer duration	Motor starting Load variations Load dropping
Voltage flicker	RMS voltage, steady state, repetitive condition	Intermittent loads Motor starting Arc furnaces
Harmonic distortion	Steady state current or voltage, long-term duration	Non-linear loads System resonance

Table 1.3: Typical Power Quality Problems and Sources

It is often assumed that power quality problems originate with the utility. While it is true that many power quality problems can originate with the utility system, many problems originate with customer equipment. Customer-caused problems may manifest themselves inside the customer location or they may be transported by the utility system to another adjacent customer. Often, equipment that is sensitive to power quality problems may in fact also be the cause of the problem.

If a power quality problem is suspected, it is generally wise to consult a power quality professional for assistance in defining the cause and possible solutions to the problem.



## 2: Shark® 100S Submeter Overview and Specifications

### 2.1: Hardware Overview

The Shark® 100S multifunction submeter is designed to measure revenue grade electrical energy usage and communicate that information via various communication media. The unit supports RS485, RJ45 wired Ethernet or IEEE 802.11 WiFi Ethernet connections. This allows the Shark® 100S submeter to be placed anywhere within an industrial or commercial facility and still communicate quickly and easily back to central software. The unit also has a front IrDA port that can be read and configured with an IrDA-equipped device, such as a laptop PC.

The unit is designed with advanced measurement capabilities, allowing it to achieve high performance accuracy. The Shark® 100S meter is specified as a 0.2% class energy meter for billing applications. To verify the submeter's performance and calibration, power providers use field test standards to verify that the unit's energy measurements are correct. The Shark® 100S meter is a traceable revenue meter and contains a utility grade test pulse to verify rated accuracy. UL 61010-1 does not address performance criteria for revenue generating watt-hour meters for use in metering of utilities and/or communicating directly with utilities, or use within a substation. Use in revenue metering, communicating with utilities, and use in substations was verified according to the ANSI and IEC standards listed in Compliance Section (2.3).



#### **Shark® 100S meter features detailed in this manual are:**

- 0.2% Class Revenue Certifiable Energy and Demand Submeter
- Meets ANSI C12.20 (0.2%) and IEC 62053-22 (0.2%) Classes
- Multifunction Measurement including Voltage, Current, Power, Frequency, Energy, etc.

- Power quality measurements (% THD and alarm limits)
- Three line 0.56" bright red LED display
- V-switch™ technology - upgrade in the field without removing installed meter
- Percentage of Load bar for Analog meter perception
- Modbus® RTU (over Serial) and Modbus® TCP (over Ethernet)
- Serial RS485 communication
- Ethernet and wireless Ethernet (WiFi)
- Easy to use faceplate programming
- IrDA port for laptop PC remote read
- Direct interface with most Building Management systems

The Shark® 100S submeter uses standard 5 or 1 Amp CTs (either split or donut). It surface mounts to any wall and is easily programmed. The unit is designed specifically for easy installation and advanced communication.

### 2.1.1: Model Number plus Option Numbers

Model	Frequency	Current Class	V-Switch™ Pack	Power Supply	Communication Format
Shark® 100S Submeter	-50 50 Hz System	-10 5 Amp Secondary	-V3 Default with Energy Counters	-D2 (90-400) VAC (100- 370)VDC	-485 RS485
	-60 60 Hz System	-2 1 Amp Secondary	-V4 Above with Harmonics and Limits		-WIFI Wireless and LAN Based (Also configurable for RS485)

#### Example:

Shark 100S    - 60    - 10    - V3    - D2    - 485

which translates to a Shark® 100S submeter with a 60Hz system, Current class 10, Default V-Switch™, D2 power supply, and RS485 communication.

### 2.1.2: V-Switch™ Technology

The Shark® 100S meter is equipped with EIG's exclusive V-Switch™ technology. V-Switch™ technology is a virtual firmware-based switch that allows you to enable meter features through communication. This allows the unit to be upgraded after installation to a higher model without removing it from service.

#### Available V-Switch™ Keys

V-Switch™ 3 (V-3): Volts, Amps, kW, kVAR, PF, kVA, Freq., kWh, kVAh, kVARh & DNP 3.0

V-Switch™ 4 (V-4): Volts, Amps, kW, kVAR, PF, kVA, Freq., kWh, kVAh, kVARh, %THD Monitoring, Limit Exceeded Alarms & DNP 3.0

### 2.1.3: Measured Values

The Shark® 100S meter provides the following measured values all in real time and some additionally as average, maximum and minimum values.

<b>Shark® 100S Meter Measured Values</b>				
<b>Measured Values</b>	<b>Real Time</b>	<b>Average</b>	<b>Maximum</b>	<b>Minimum</b>
Voltage L-N	X		X	X
Voltage L-L	X		X	X
Current per Phase	X	X	X	X
Current Neutral	X			
Watts	X	X	X	X
VAR	X	X	X	X
VA	X	X	X	X
PF	X	X	X	X
+Watt-hr	X			
-Watt-hr	X			
Watt-hr Net	X			
+VAR-hr	X			
-VAR-hr	X			
VAR-hr Net	X			
VA-hr	X			
Frequency	X		X	X
%THD**	X		X	X
Voltage Angles	X			
Current Angles	X			
% of Load Bar	X			

\*\* The Shark® 100S meter measures harmonics up to the 7th order for Current and up to the 3rd order for Voltage.

### 2.1.4: Utility Peak Demand

The Shark® 100S meter provides user-configured Block (Fixed) window or Rolling window Demand. This feature allows you to set up a customized Demand profile. Block window Demand is Demand used over a user-configured Demand period (usually 5, 15 or 30 minutes). Rolling window Demand is a fixed window Demand that moves for a user-specified subinterval period.

For example, a 15-minute Demand using 3 subintervals and providing a new Demand reading every 5 minutes, based on the last 15 minutes.

Utility Demand features can be used to calculate kW, kVAR, kVA and PF readings. All other parameters offer Max and Min capability over the user-selectable averaging period. Voltage provides an Instantaneous Max and Min reading which displays the highest surge and lowest sag seen by the meter

## 2.2: Specifications

### Power Supply

Range: Universal, (90 to 400)VAC  
@50/60 Hz or  
(100 to 370)VDC

Power Consumption: 16 VA Maximum

### Voltage Inputs (Measurement Category III)

Range: Universal, Auto-ranging up to  
416 VAC L-N, 721 VAC L-L

Supported hookups: 3 Element Wye, 2.5 Element Wye,  
2 Element Delta, 4 Wire Delta

Input Impedance: 1M Ohm/Phase

Burden: 0.36VA/Phase Max at 600 V,  
0.0144 VA/Phase at 120 V

Pickup Voltage: 10 VAC

Connection: Screw terminal - #6 - 32 screws  
See Figure 4.1

Input Wire Gauge:	AWG#16 - 26
Fault Withstand:	Meets IEEE C37.90.1 (Surge Withstand Capability)
Reading:	Programmable Full Scale to any PT Ratio

### Current Inputs

Class 10:	5 A Nominal, 10 A Maximum
Class 2:	1 A Nominal, 2 A Secondary
Burden:	0.005 VA Per Phase Max at 11 A
Pickup Current:	0.1% of Nominal
Connections:	Screw terminal - #6-32 screws (Diagram 4.1)
Current Surge Withstand:	100 A/10 seconds at 23° C
Reading:	Programmable Full Scale to any CT Ratio

### Isolation

All Inputs and Outputs are galvanically isolated and tested to 2500 VAC

### Environmental Rating

Storage:	(-20 to +60) °C
Operating:	(-20 to +60) °C
Humidity:	to 95% RH Non-condensing
Faceplate Rating:	NEMA 1

**Measurement Methods**

Voltage, Current:	True RMS
Power:	Sampling at 400+ Samples per Cycle on All Channels Measured Readings Simultaneously
Harmonic %THD	% of Total Harmonic Distortion
A/D Conversion:	6 Simultaneous 24 Bit Analog to Digital Converters

**Update Rate**

Watts, VAR and VA:	Every 6 cycles, e.g., 100 milliseconds (Ten times per second) @60 Hz
All other parameters:	Every 60 cycles, e.g, 1 second @60 Hz

**Communication Format**

1. RS485	
2. IrDA Port through Face Plate	
Protocols:	Modbus RTU, Modbus ASCII, DNP 3.0, Modbus TCP (for Ethernet-enabled)
Com Port Baud Rate:	9600 to 57600 b/s
Com Port Address:	001-247
Data Format:	8 Bit, No Parity

**Wireless Ethernet (Optional)**

802.11b Wireless or 10/100BaseT Ethernet	WiFi or RJ45 Connection
--	-------------------------

Wireless Security 64 or 128 bit WEP; WPA; or WPA2

Modbus TCP Protocol

### **Mechanical Parameters**

Dimensions: (H7.9 x W7.6 x D3.2) inches,  
(H200.7 x W193.0 x D81.3) mm

Weight: 4 pounds/1.814 kilograms

### **KYZ/RS485 Port Specifications**

RS485 Transceiver; meets or exceeds EIA/TIA-485 Standard:

Type: Two-wire, half duplex

Min. Input Impedance: 96k $\Omega$

Max. Output Current:  $\pm$ 60 mA

### **Wh Pulse**

KYZ output contacts (and infrared LED light pulses through face plate; see Section 7.4 for Kh values):

Pulse Width: 40 ms

Full Scale Frequency:  $\sim$ 6 Hz

Contact type: Solid State – SPDT (NO – C – NC)

Relay type: Solid state

Peak switching voltage: DC  $\pm$ 350 V

Continuous load current: 120 mA

Peak load current: 350 mA for 10 ms

On resistance, max.: 35 $\Omega$

Leakage current: 1 $\mu$ A@350 V

Isolation: AC 3750 V

Reset State: (NC - C) Closed; (NO - C) Open



Infrared LED:

Peak Spectral Wavelength: 940 nm

Reset State: Off

**Internal Schematic:**

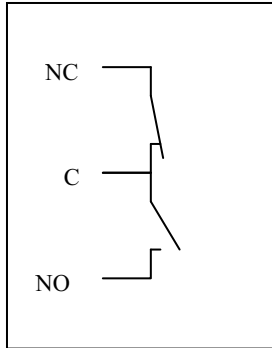

(De-energized state)

**Output Timing:**

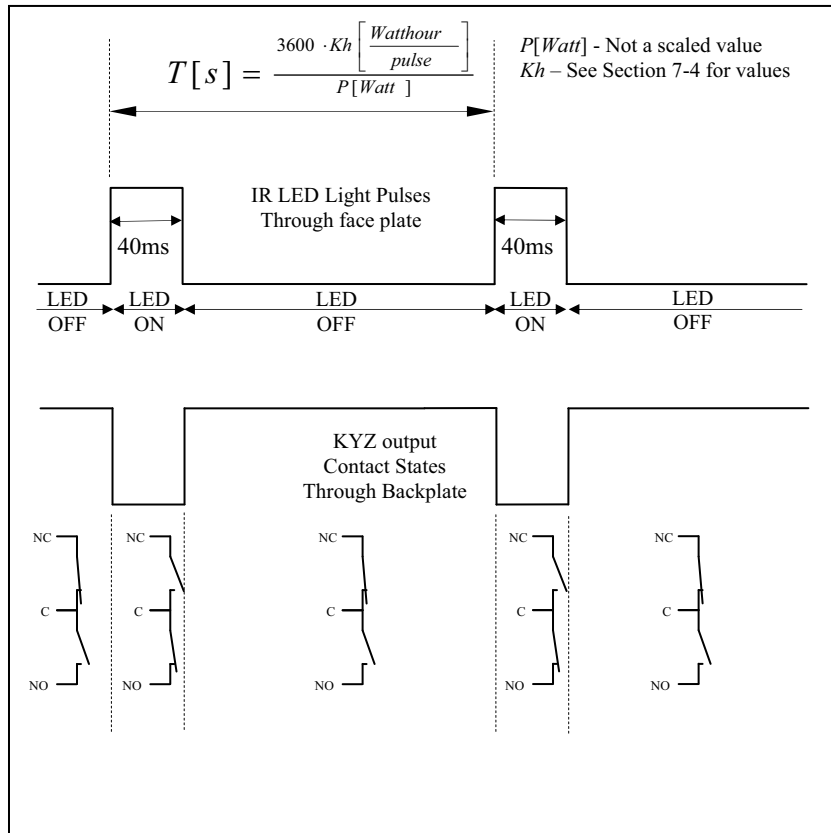

## 2.3: Compliance

- IEC 62053-22 (0.2% Accuracy)
- ANSI C12.20 (0.2% Accuracy)
- ANSI (IEEE) C37.90.1 Surge Withstand
- ANSI C62.41 (Burst)
- EN61000-6-2 Immunity for Industrial Environments: 2005
- EN61000-6-4 Emission Standards for Industrial Environments: 2007
- EN61326-1 EMC Requirements: 2006
- Certified to UL 61010-1 and CSA C22.2 No. 61010-1, UL File: E250818
- CE Compliant

## 2.4: Accuracy

For 23°C, 3 Phase balanced Wye or Delta load, at 50 or 60 Hz (as per order), 5A (Class 10) nominal unit:

Parameter	Accuracy	Accuracy Input Range
Voltage L-N [V]	0.1% of reading <sup>2</sup>	(69 to 480)V
Voltage L-L [V]	0.1% of reading	(120 to 600)V
Current Phase [A]	0.1% of reading <sup>1</sup>	(0.15 to 5)A
Current Neutral (calculated) [A]	2.0% of Full Scale <sup>1</sup>	(0.15 to 5)A @ (45 to 65)Hz
Active Power Total [W]	0.2% of reading <sup>1,2</sup>	(0.15 to 5)A @ (69 to 480)V @ +/- (0.5 to 1) lag/lead PF
Active Energy Total [Wh]	0.2% of reading <sup>1,2</sup>	(0.15 to 5)A @ (69 to 480)V @ +/- (0.5 to 1) lag/lead PF
Reactive Power Total [VAR]	0.2% of reading <sup>1,2</sup>	(0.15 to 5)A @ (69 to 480)V @ +/- (0 to 0.8) lag/lead PF
Reactive Energy Total [VARh]	0.2% of reading <sup>1,2</sup>	(0.15 to 5)A @ (69 to 480)V @ +/- (0 to 0.8) lag/lead PF
Apparent Power Total [VA]	0.2% of reading <sup>1,2</sup>	(0.15 to 5)A @ (69 to 480)V @ +/- (0.5 to 1) lag/lead PF
Apparent Energy Total [VAh]	0.2% of reading <sup>1,2</sup>	(0.15 to 5)A @ (69 to 480)V @ +/- (0.5 to 1) lag/lead PF

Power Factor	0.2% of reading <sup>1,2</sup>	(0.15 to 5)A @ (69 to 480)V @ +/- (0.5 to 1) lag/lead PF
Frequency	+/- 0.01Hz	(45 to 65)Hz
Total Harmonic Distortion (%)	5.0% <sup>1</sup>	(0.5 to 10)A or (69 to 480)V, measurement range (1 to 99.99)%
Load Bar	+/- 1 segment <sup>1</sup>	(0.005 to 6)A

<sup>1</sup> For 2.5 element programmed units, degrade accuracy by an additional 0.5% of reading.

- For 1 A (Class 2) Nominal, degrade accuracy by an additional 0.5% of reading.
- For 1 A (Class 2) Nominal, the input current range for Accuracy specification is 20% of the values listed in the table.

<sup>2</sup> For unbalanced voltage inputs where at least one crosses the 150 V auto-scale threshold (for example, 120 V/120 V/208 V system), degrade accuracy by additional 0.4%.

## 3: Mechanical Installation

### 3.1: Overview

The Shark 100S meter can be installed on any wall. See Chapter 4 for wiring diagrams.

Mount the meter in a dry location, which is free from dirt and corrosive substances.

#### Recommended Tools for Shark 100S Installation

- #2 Phillips screwdriver
- Wire cutters



**WARNING!** During normal operation of the Shark® 100S meter, dangerous voltages flow through many parts of the meter, including: Terminals and any connected CTs (Current Transformers) and PTs (Potential Transformers), all I/O Modules (Inputs and Outputs) and their circuits. All

Primary and Secondary circuits can, at times, produce lethal voltages and currents. Avoid contact with any current-carrying surfaces. **Before performing ANY work on the meter, make sure the meter is powered down and all connected circuits are de-energized.**

**AVERTISSEMENT!** Pendant le fonctionnement normal du compteur Shark® 100S des tensions dangereuses suivent de nombreuses pièces, notamment, les bornes et tous les transformateurs de courant branchés, les transformateurs de tension, toutes les sorties, les entrées et leurs circuits. Tous les circuits secondaires et primaires peuvent parfois produire des tensions de létal et des courants. Évitez le contact avec les surfaces sous tensions. **Avant de faire un travail dans le compteur, assurez-vous d'éteindre l'alimentation et de mettre tous les circuits branchés hors tension.**

### 3.2: Install the Base

1. Determine where you want to install the submeter.
2. **With the submeter power off**, open the top of the submeter. Use the front cover support to keep the cover open as you perform the installation (see Figure 3.1).

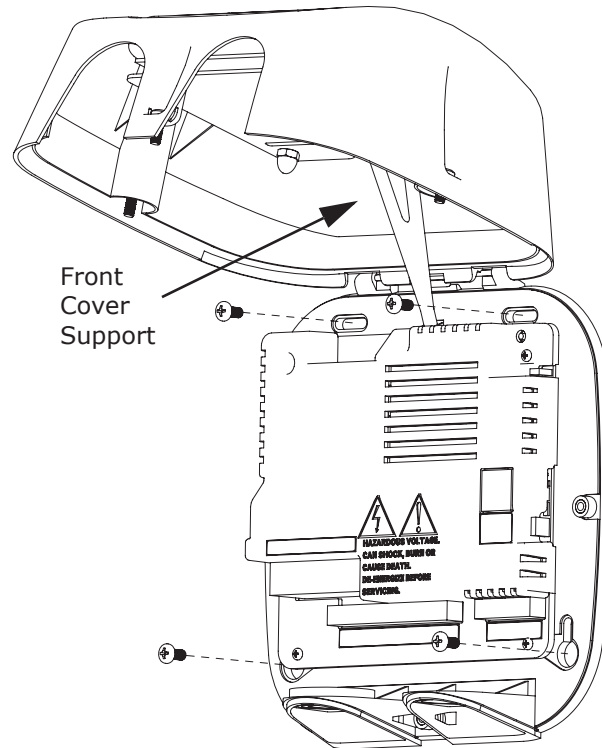

Figure 3.1: Shark Submeter with Cover Open: see WARNING! on previous page

#### CAUTIONS!

- Remove the antenna before opening the unit.
  - Only use the front cover support if you are able to open the front cover to the extent that you can fit the front cover support into its base. **DO NOT** rest the front cover support on the inside of the meter, even for a short time - by doing so, you may damage components on the board assembly.
3. Find the 4 Installation Slots and insert screws through each slot into the wall or panel.
  4. Fasten securely - DO NOT overtighten.

### 3.2.1: Mounting Diagrams

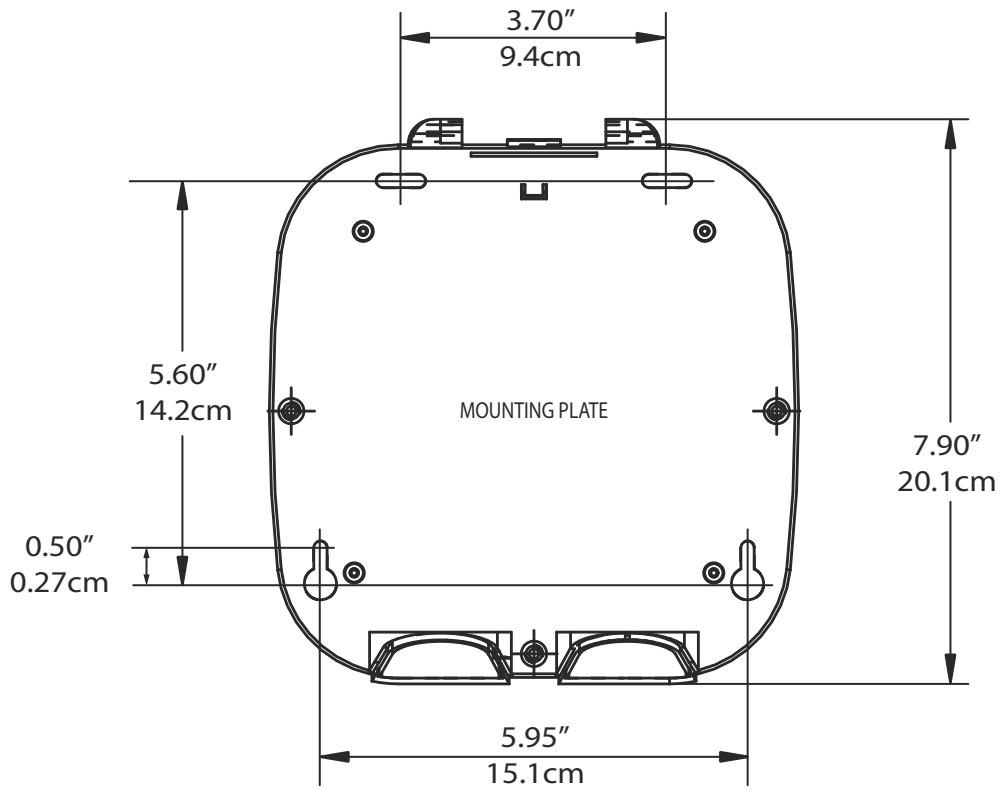
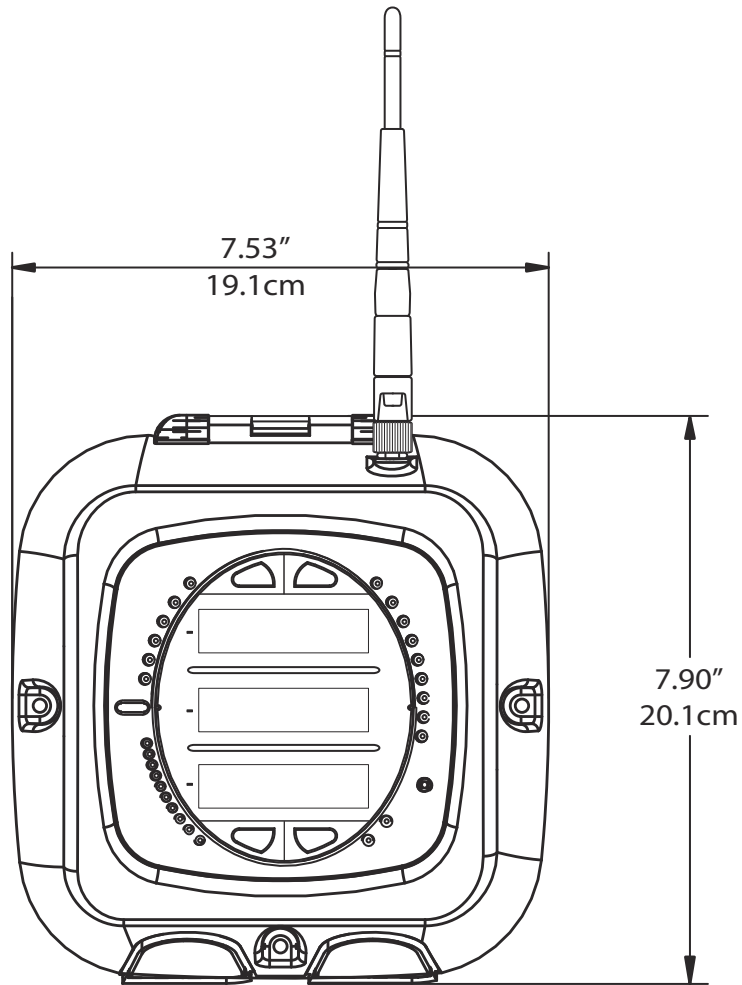

Figure 3.2: Mounting Plate Dimensions



Antenna Length: 4.4" (11.2cm)

Figure 3.3: Front Dimensions

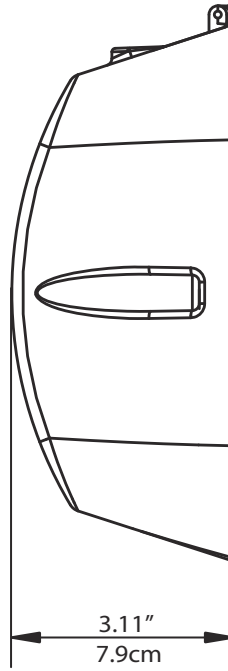

Figure 3.4: Side Dimensions



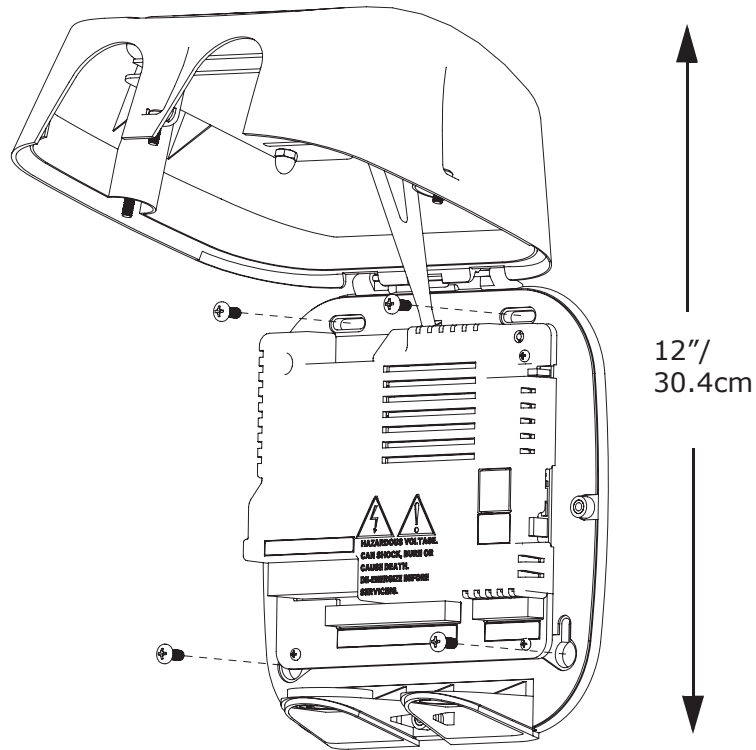

Figure 3.5: Open Cover Dimensions

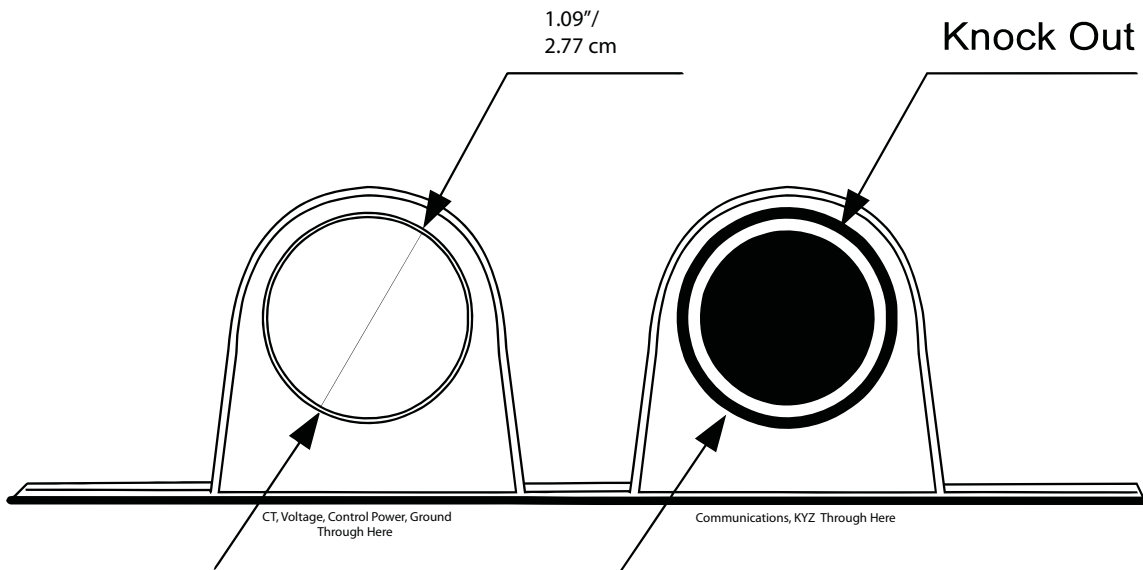

Figure 3.6: Bottom View with Access Holes

### 3.3: Secure the Cover

1. Close the cover, making sure that power and communications wires exit the submeter through the openings at the base (see Figure 3.6).

**CAUTION!** To avoid damaging components on the board assembly, make sure the front cover support is in the upright position before closing the front cover.

2. Using the 3 enclosed screws, secure the cover to the base in three places - DO NOT overtighten (you may damage the cover).
3. The unit can be sealed after the front cover is closed. To seal the unit, thread the seal tag through the housing located between the bottom access holes (see figures 3.6 and 3.7).
4. Reattach the antenna, if applicable.

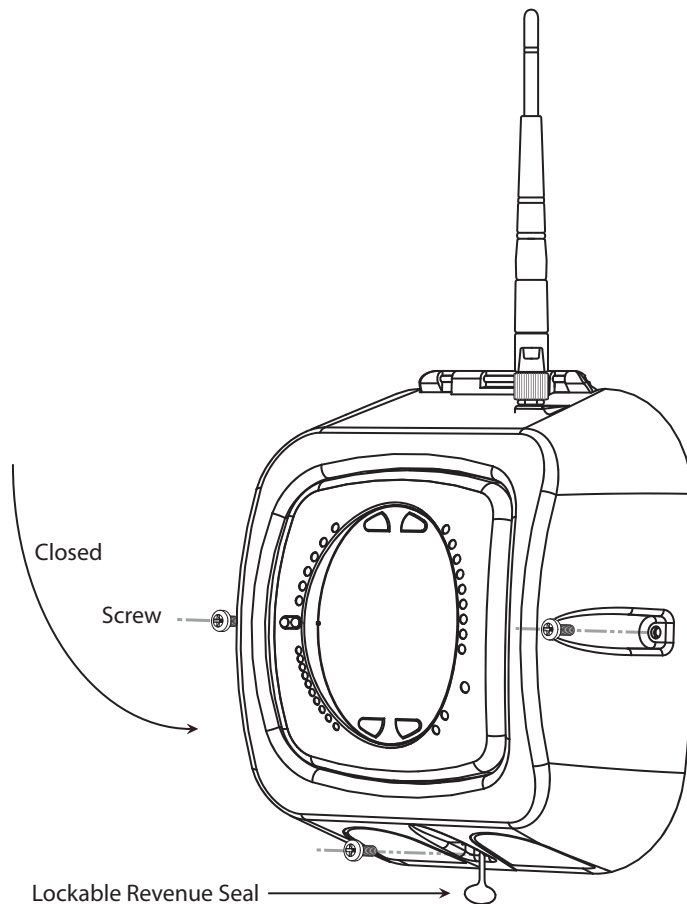

Figure 3.7: Submeter with Closed Cover

## 4: Electrical Installation

### 4.1: Considerations When Installing Meters



Installation of the Shark® 100S meter must be performed only by qualified personnel who follow standard safety precautions during all procedures. Those personnel should have appropriate training and experience with high voltage devices. Appropriate safety gloves, safety glasses and protective clothing is recommended.

**WARNING!** During normal operation of the Shark® 100S meter, dangerous voltages flow through many parts of the meter, including: Terminals and any connected CTs (Current Transformers) and PTs (Potential Transformers), all I/O Modules (Inputs and Outputs) and their circuits. All Primary and Secondary circuits can, at times, produce lethal voltages and currents. Avoid contact with any current-carrying surfaces. **Before performing ANY work on the meter, make sure the meter is powered down and all connected circuits are de-energized.**

**Do not use the meter or any I/O Output Device for primary protection or in an energy-limiting capacity. The meter can only be used as secondary protection.**

Do not use the meter for applications where failure of the meter may cause harm or death.

Do not use the meter for any application where there may be a risk of fire.

All meter terminals should be inaccessible after installation.

Do not apply more than the maximum voltage the meter or any attached device can withstand. Refer to meter and/or device labels and to the Specifications for all devices before applying voltages.

Do not HIPOT/Dielectric test any Outputs, Inputs or Communications terminals.

EIG requires the use of Fuses for voltage leads and power supply and Shorting Blocks to prevent hazardous voltage conditions or damage to CTs, if the meter needs to be removed from service. CT grounding is optional, but recommended.

**NOTE:** The current inputs are only to be connected to external current transformers provided by the installer. The CT's shall be Approved or Certified and rated for the current of the meter used.



L'installation des compteurs de Shark® 100S doit être effectuée seulement par un personnel qualifié qui suit les normes relatives aux précautions de sécurité pendant toute la procédure. Le personnel doit avoir la formation appropriée et l'expérience avec les appareils de haute tension. Des gants de sécurité, des verres et des vêtements de protection appropriés sont recommandés.

**AVERTISSEMENT!** Pendant le fonctionnement normal du compteur Shark® 100S des tensions dangereuses suivant de nombreuses pièces, notamment, les bornes et tous les transformateurs de courant branchés, les transformateurs de tension, toutes les sorties, les entrées et leurs circuits. Tous les circuits secondaires et primaires peuvent parfois produire des tensions de léthal et des courants. Évitez le contact avec les surfaces sous tensions. Avant de faire un travail dans le compteur, assurez-vous d'éteindre l'alimentation et de mettre tous les circuits branchés hors tension.

**Ne pas utiliser les compteurs ou sorties d'appareil pour une protection primaire ou capacité de limite d'énergie. Le compteur peut seulement être utilisé comme une protection secondaire.**

Ne pas utiliser le compteur pour application dans laquelle une panne de compteur peut causer la mort ou des blessures graves.

Ne pas utiliser le compteur ou pour toute application dans laquelle un risque d'incendie est susceptible.

Toutes les bornes de compteur doivent être inaccessibles après l'installation.

Ne pas appliquer plus que la tension maximale que le compteur ou appareil relatif peut résister. Référez-vous au compteur ou aux étiquettes de l'appareil et les spécifications de tous les appareils avant d'appliquer les tensions. Ne pas faire de test HIPOT/diélectrique, une sortie, une entrée ou un terminal de réseau.

Les entrées actuelles doivent seulement être branchées aux transformateurs externes actuels.

EIG nécessite l'utilisation de les fusibles pour les fils de tension et alimentations électriques, ainsi que des coupe-circuits pour prévenir les tensions dangereuses ou endommagements de transformateur de courant si l'unité Shark® 100S doit être enlevée du service. Un côté du transformateur de courant doit être mis à terre.

**NOTE:** les entrées actuelles doivent seulement être branchées dans le transformateur externe actuel par l'installateur. Le transformateur de courant doit être approuvé ou certifié et déterminé pour le compteur actuel utilisé.

**IMPORTANT!**



**IF THE EQUIPMENT IS USED IN A MANNER NOT SPECIFIED BY THE MANUFACTURER, THE PROTECTION PROVIDED BY THE EQUIPMENT MAY BE IMPAIRED.**

- THERE IS NO REQUIRED PREVENTIVE MAINTENANCE OR INSPECTION NECESSARY FOR SAFETY. HOWEVER, ANY REPAIR OR MAINTENANCE SHOULD BE PERFORMED BY THE FACTORY.



**DISCONNECT DEVICE:** The following part is considered the equipment disconnect device. A SWITCH OR CIRCUIT-BREAKER SHALL BE INCLUDED IN THE END-USE EQUIPMENT OR BUILDING INSTALLATION. THE SWITCH SHALL BE IN CLOSE PROXIMITY TO THE EQUIPMENT AND WITHIN EASY REACH OF THE OPERATOR. THE SWITCH SHALL BE MARKED AS THE DISCONNECTING DEVICE FOR THE EQUIPMENT.



**IMPORTANT! SI L'ÉQUIPEMENT EST UTILISÉ D'UNE FAÇON NON SPÉCIFIÉE PAR LE FABRICANT, LA PROTECTION FOURNIE PAR L'ÉQUIPEMENT PEUT ÊTRE ENDOMMAGÉE.**

**NOTE:** II N'Y A AUCUNE MAINTENANCE REQUISE POUR LA PRÉVENTION OU INSPECTION NÉCESSAIRE POUR LA SÉCURITÉ. CEPENDANT, TOUTE RÉPARATION OU MAINTENANCE DEVRAIT ÊTRE RÉALISÉE PAR LE FABRICANT.



**DÉBRANCHEMENT DE L'APPAREIL :** la partie suivante est considérée l'appareil de débranchement de l'équipement. UN INTERRUPTEUR OU UN DISJONCTEUR DEVRAIT ÊTRE INCLUS DANS L'UTILISATION FINALE DE L'ÉQUIPEMENT OU L'INSTALLATION. L'INTERRUPTEUR DOIT ÊTRE DANS UNE PROXIMITÉ PROCHE DE L'ÉQUIPEMENT ET A LA PORTÉE DE L'OPÉRATEUR. L'INTERRUPTEUR DOIT AVOIR LA MENTION DÉBRANCHEMENT DE L'APPAREIL POUR L'ÉQUIPEMENT.

## 4.2: Electrical Connections

All wiring for the Shark® 100S is done through the front of the unit (lifting the cover with the power to the unit OFF) so that the unit can be surface mounted. Connecting cables exit the unit via two openings in the base plate (see figures 3.6 and 4.1). The enclosure is intended for use with flexible conduit and non-metallic fittings.



**WARNING!** During normal operation of the Shark® 100S meter, dangerous voltages flow through many parts of the meter, including: Terminals and any connected CTs (Current Transformers) and PTs (Potential Transformers), all I/O Modules (Inputs and Outputs) and their circuits. All Primary and Secondary circuits can, at times, produce lethal voltages and currents. Avoid contact with any current-carrying surfaces.

**Before performing ANY work on the meter, make sure the meter is powered down and all connected circuits are de-energized.**

**AVERTISSEMENT!** Pendant le fonctionnement normal du compteur Shark® 100S des tensions dangereuses suivent de nombreuses pièces, notamment, les bornes et tous les transformateurs de courant branchés, les transformateurs de tension, toutes les sorties, les entrées et leurs circuits. Tous les circuits secondaires et primaires peuvent parfois produire des tensions de létal et des courants. Évitez le contact avec les surfaces sous tensions. Avant de faire un travail dans le compteur, assurez-vous d'éteindre l'alimentation et de mettre tous les circuits branchés hors tension.

**CAUTION!** DO NOT over-torque screws.

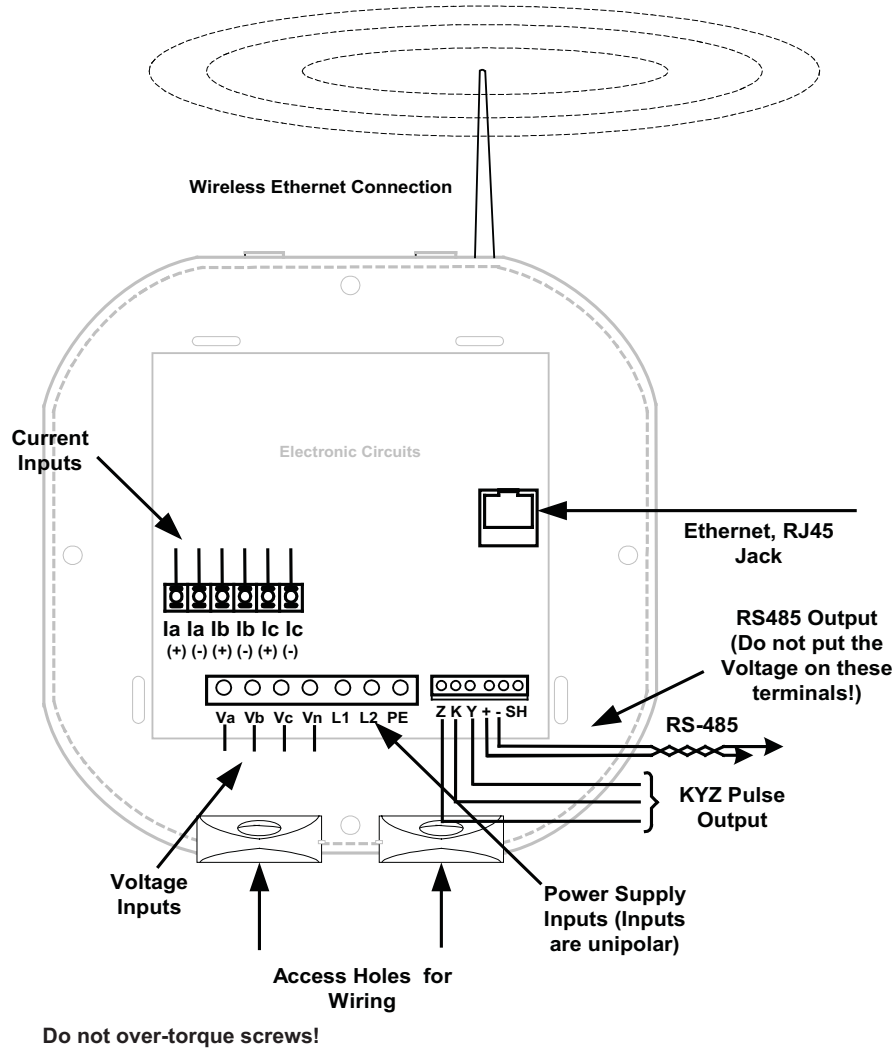

Figure 4.1: Submeter Connections

### 4.3: Ground Connections

The meter's Ground Terminal (PE) should be connected directly to the installation's protective earth ground.

### 4.4: Voltage Fuses

EIG requires the use of fuses on each of the sense voltages and on the control power.

- Use a 0.1 Amp fuse on each Voltage input.
- Use a 3 Amp fuse on the power supply.

## 4.5: Electrical Connection Diagrams

Choose the diagram that best suits your application. Make sure the CT polarity is correct.

1. Three Phase, Four-Wire System Wye with Direct Voltage, 3 Element
  - a. Dual Phase Hookup
  - b. Single Phase Hookup
2. Three Phase, Four-Wire System Wye with Direct Voltage, 2.5 Element
3. Three-Phase, Four-Wire Wye with PTs, 3 Element
4. Three-Phase, Four-Wire Wye with PTs, 2.5 Element
5. Three-Phase, Three-Wire Delta with Direct Voltage (No PTs, 2 CTs)
6. Three-Phase, Three-Wire Delta with Direct Voltage (No PTs, 3 CTs)
7. Three-Phase, Three-Wire Delta with 2 PTs, 2 CTs
8. Three-Phase, Three-Wire Delta with 2 PTs, 3 CTs
9. Current Only Measurement (Three Phase)
10. Current Only Measurement (Dual Phase)
11. Current Only Measurement (Single Phase)



1. Service: WYE, 4-Wire with No PTs, 3 CTs

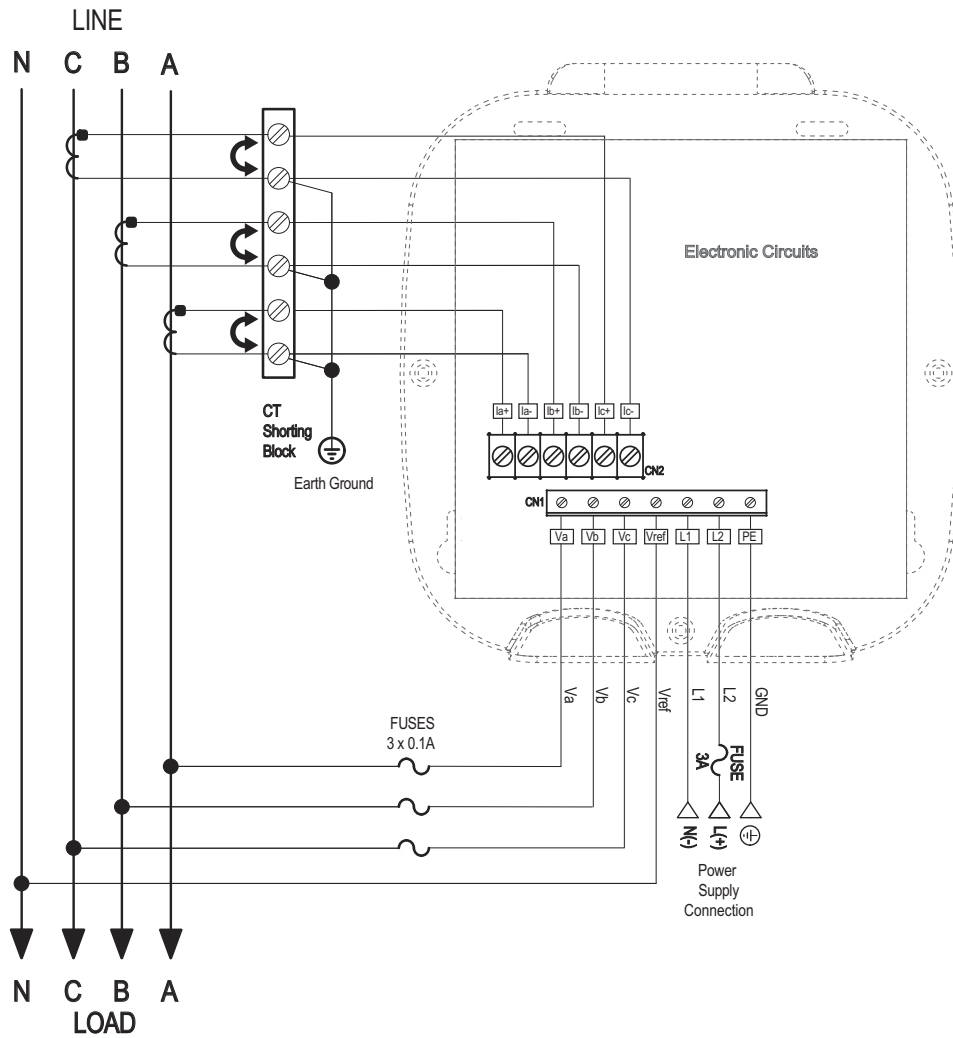

Select: "3 EL WYE" (3 Element Wye) in Meter Programming setup.

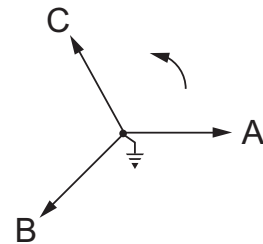

1a. Dual Phase Hookup

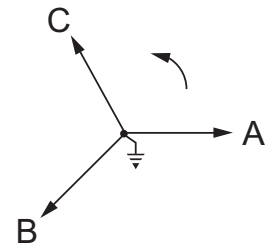
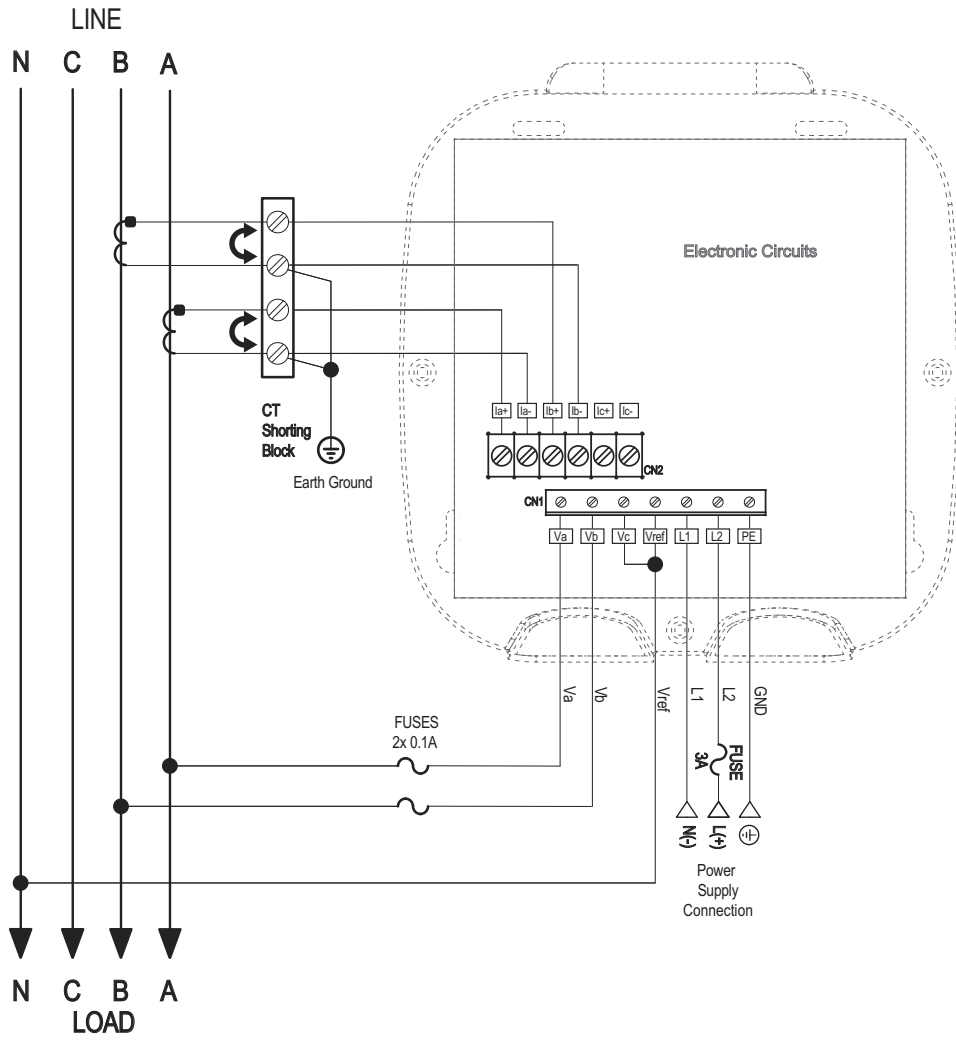

1b. Single Phase Hookup

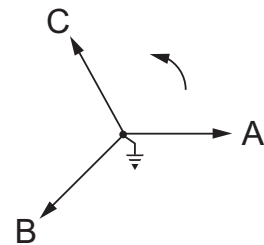
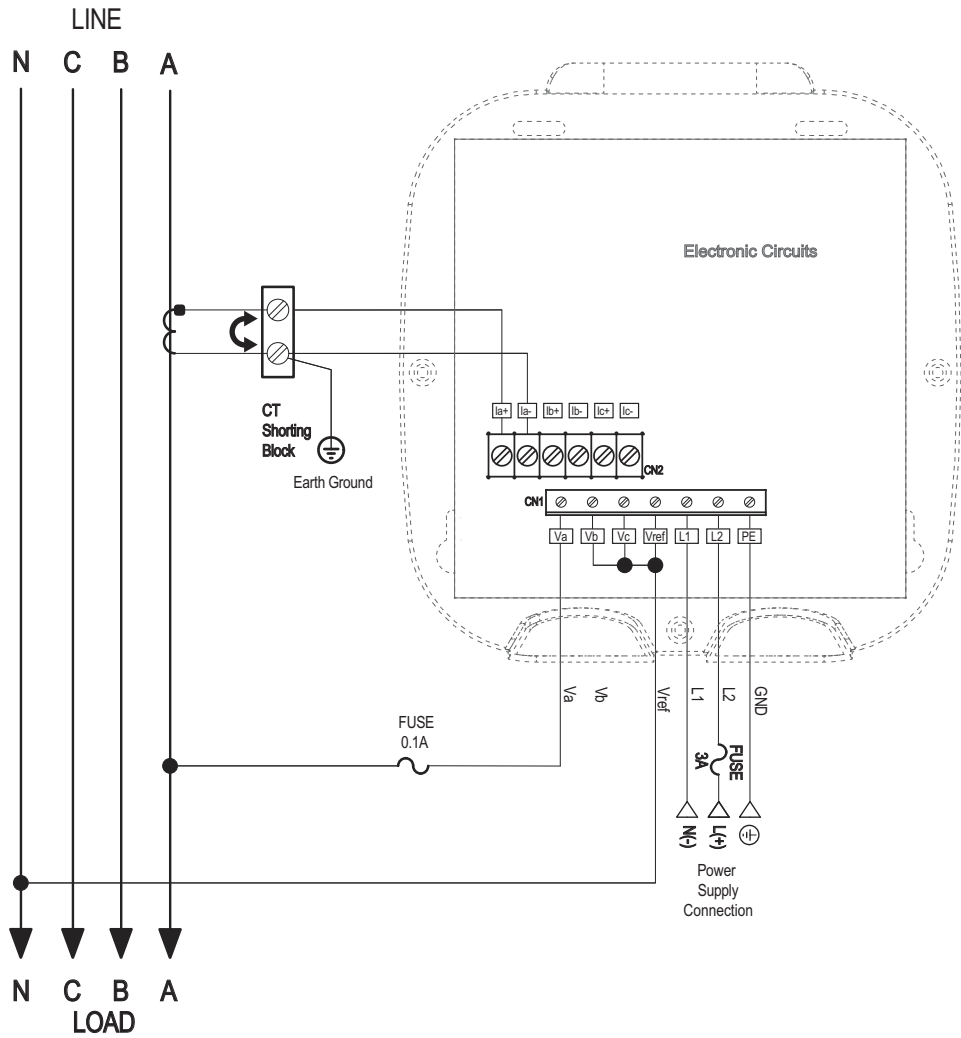

2. Service: 2.5 Element WYE, 4-Wire with No PTs, 3 CTs

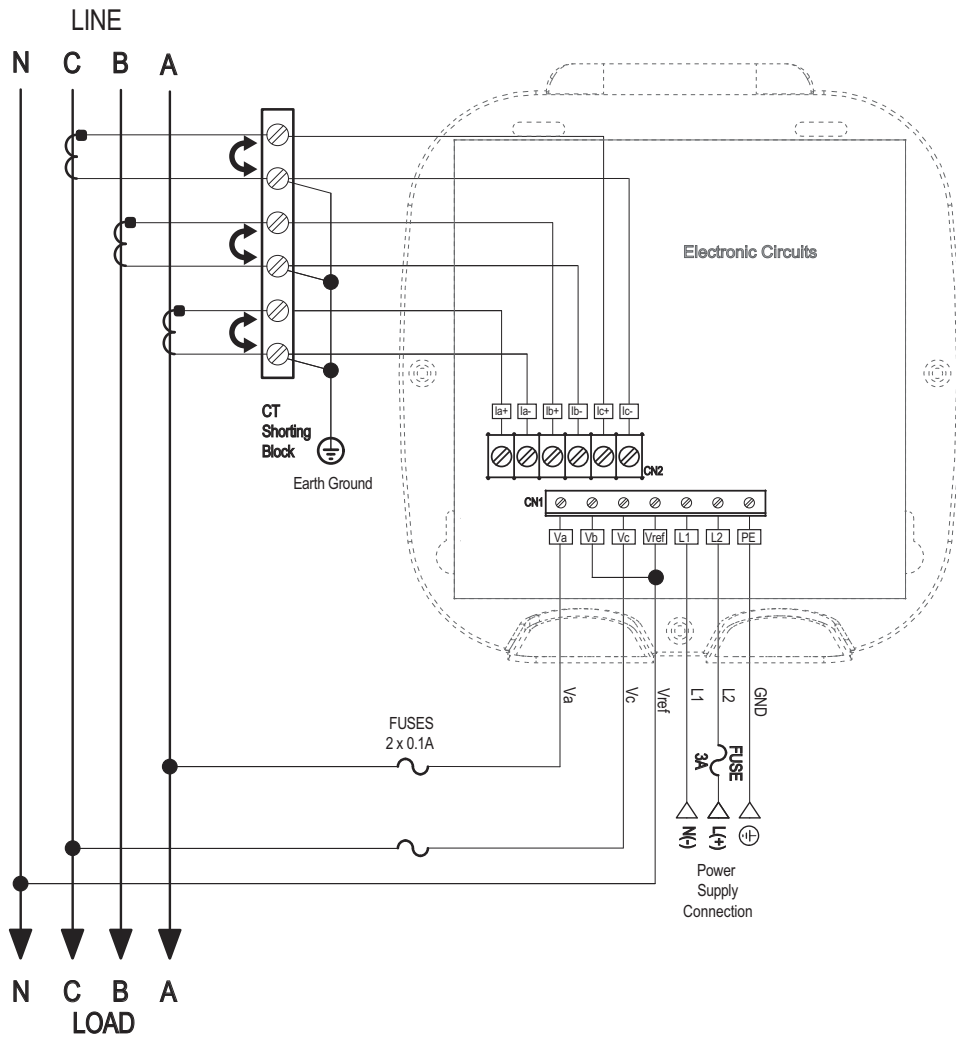

Select: "2.5 EL WYE" (2.5 Element Wye) in Meter Programming setup.

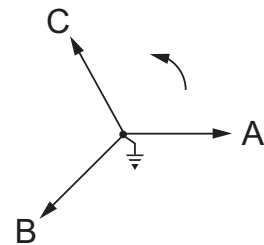

3. Service: WYE, 4-Wire with 3 PTs, 3 CTs

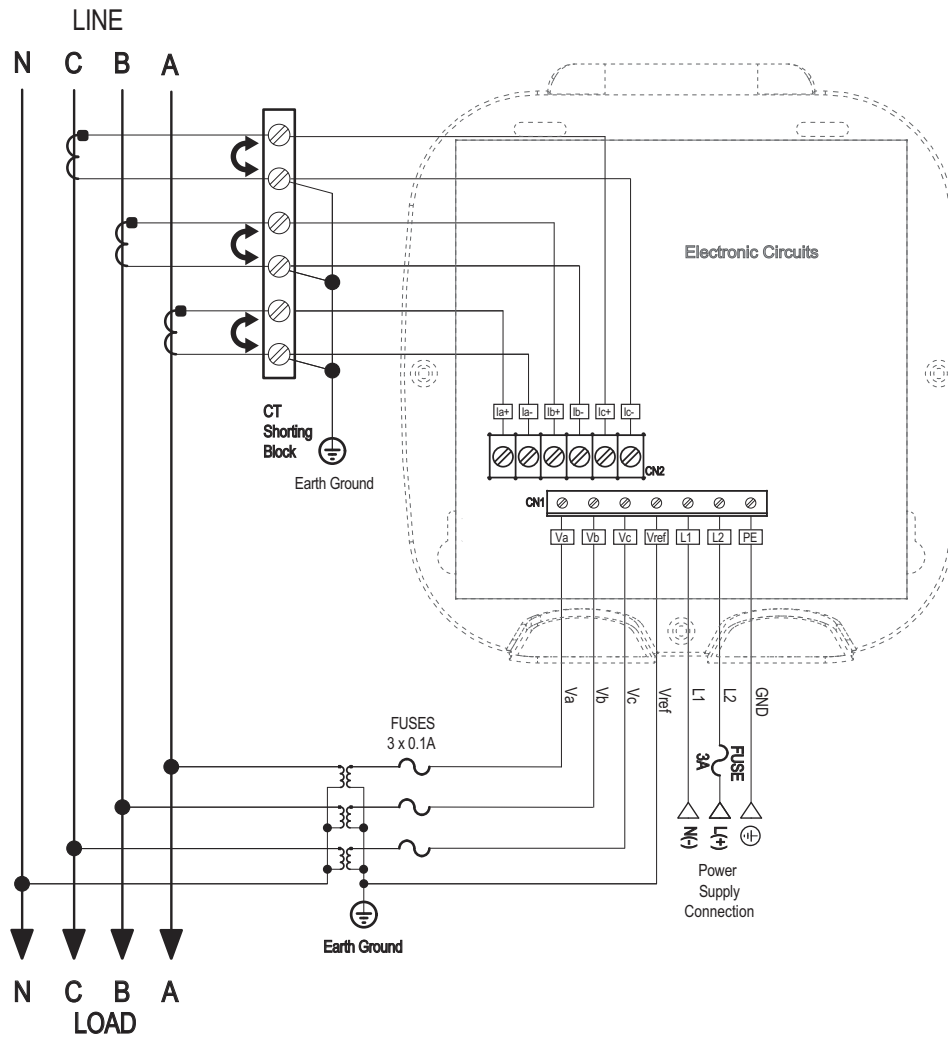

Select: "3 EL WYE" (3 Element Wye) in Meter Programming setup.

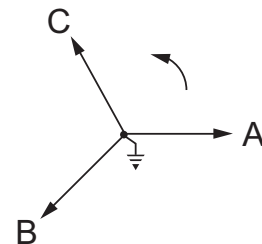

4. Service: 2.5 Element WYE, 4-Wire with 2 PTs, 3 CTs

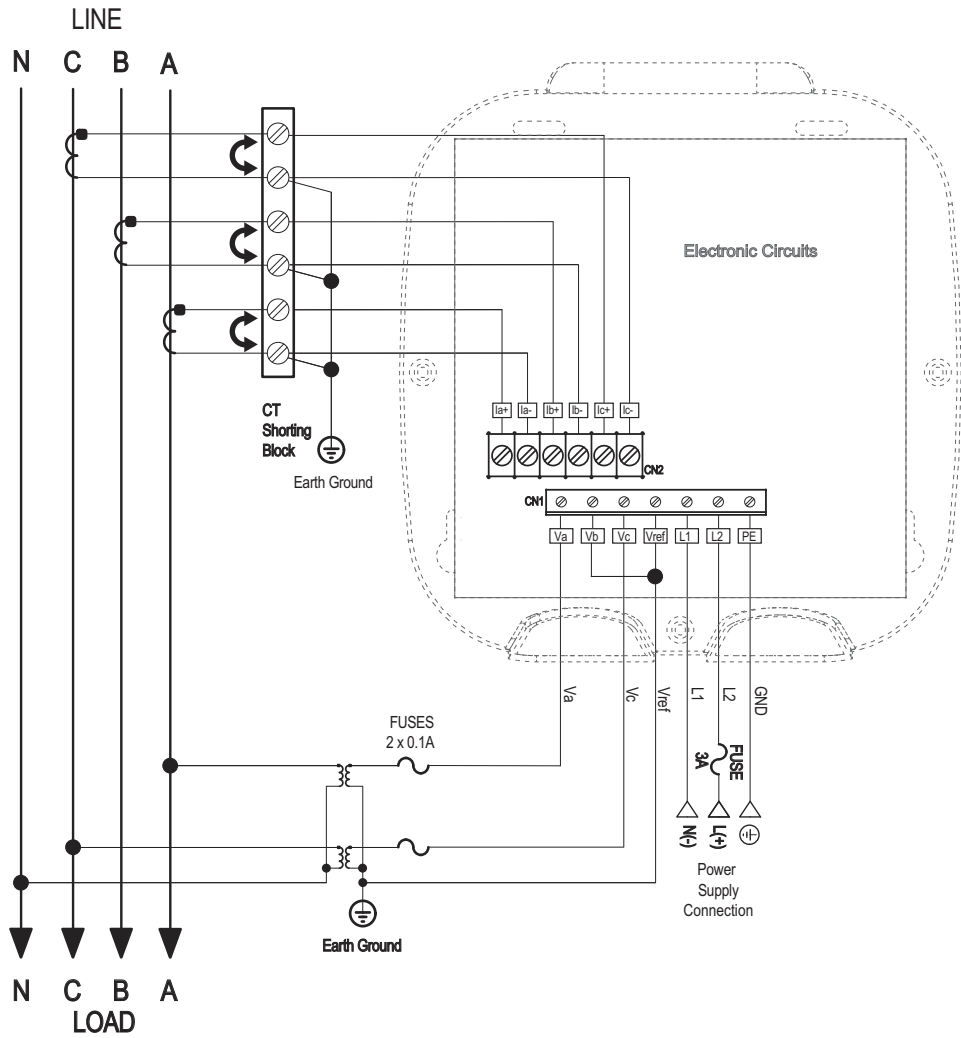

Select: "2.5 EL WYE" (2.5 Element Wye) in Meter Programming setup.

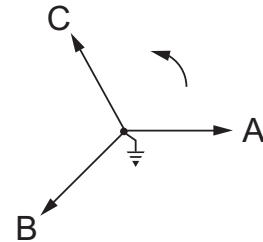

5. Service: Delta, 3-Wire with No PTs, 2 CTs

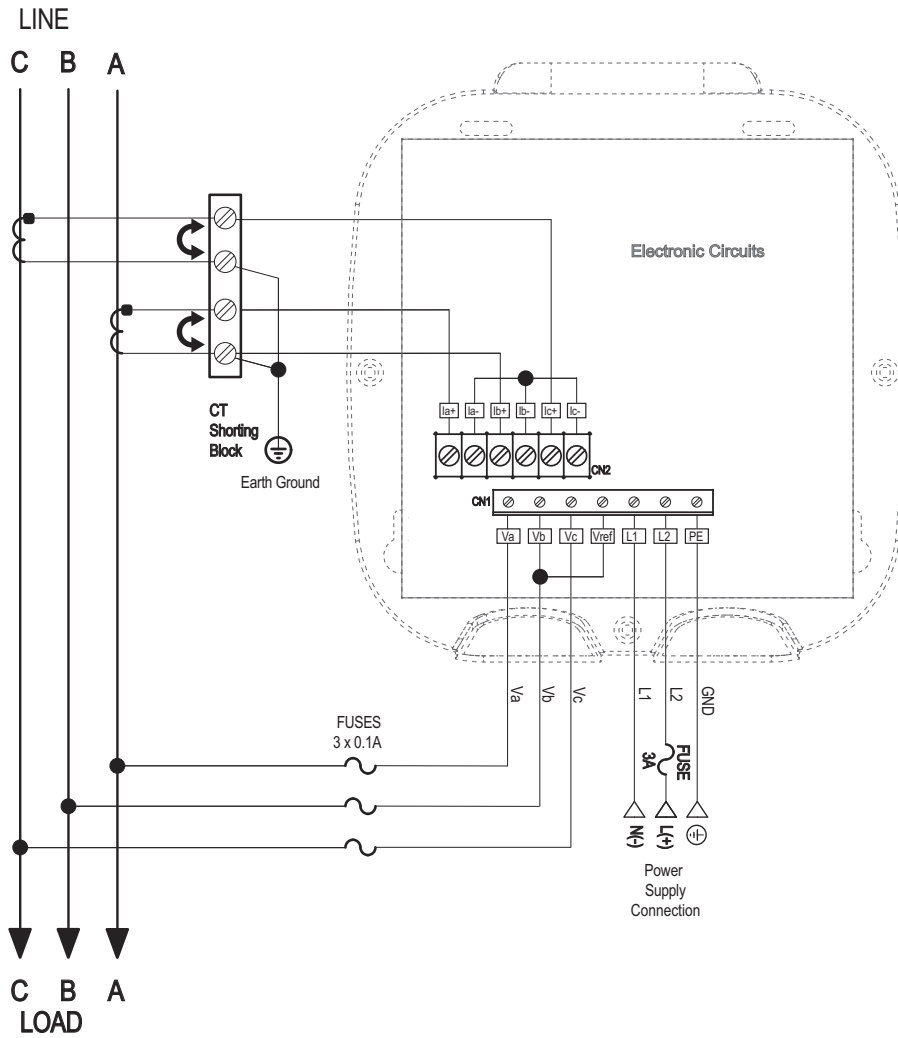

Select: "2 Ct dEL" (2 CT Delta) in Meter Programming setup.

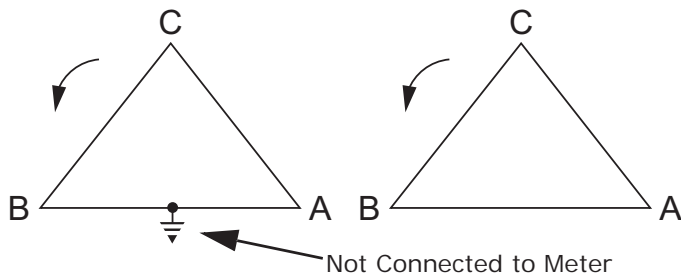

6. Service: Delta, 3-Wire with No PTs, 3 CTs

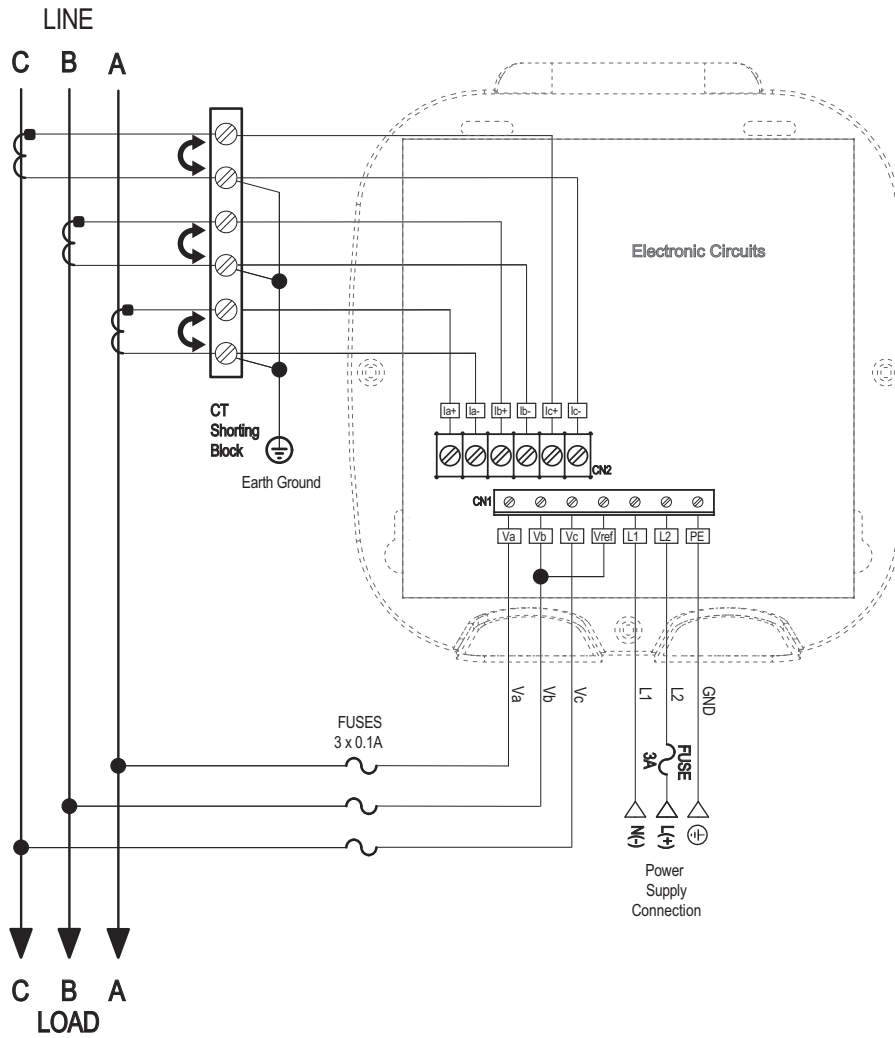

Select: "2 Ct dEL" (2 CT Delta) in Meter Programming setup.

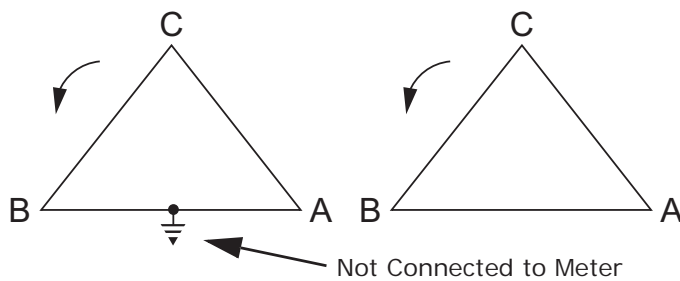



7. Service: Delta, 3-Wire with 2 PTs, 2 CTs

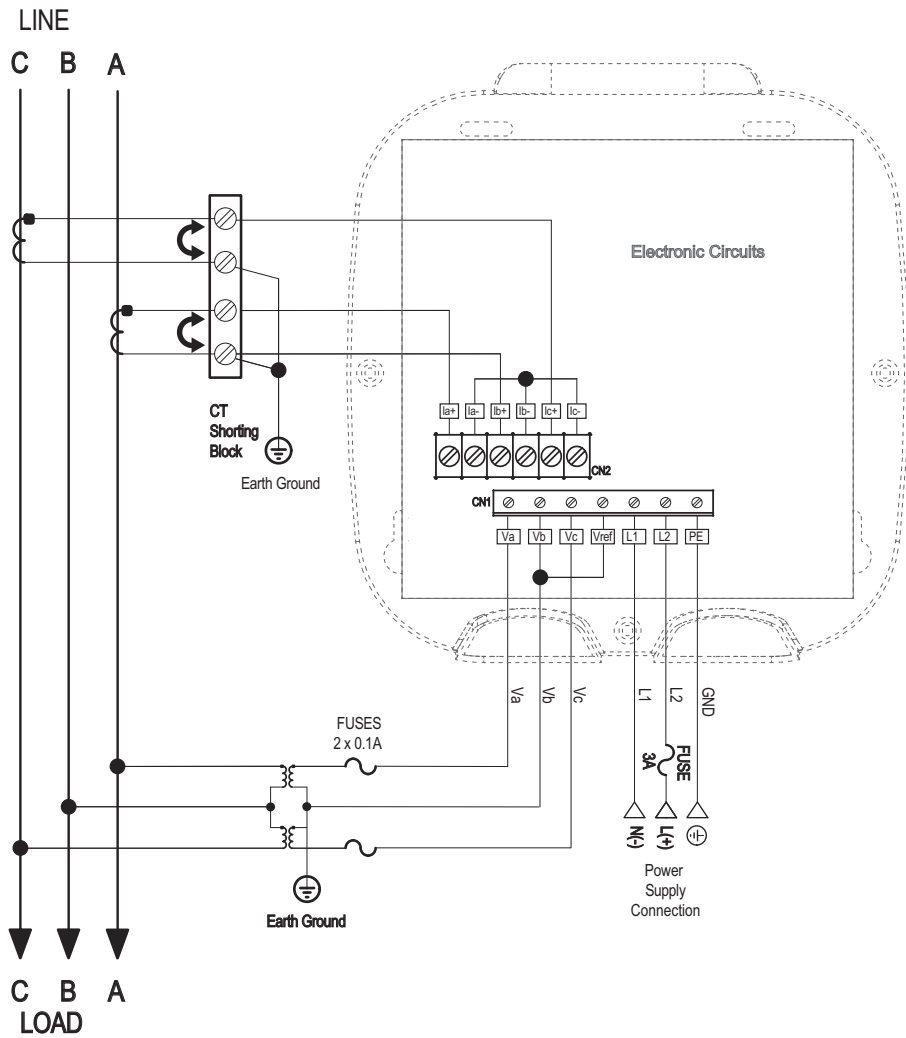

Select: "2 Ct dEL" (2 CT Delta) in Meter Programming setup.

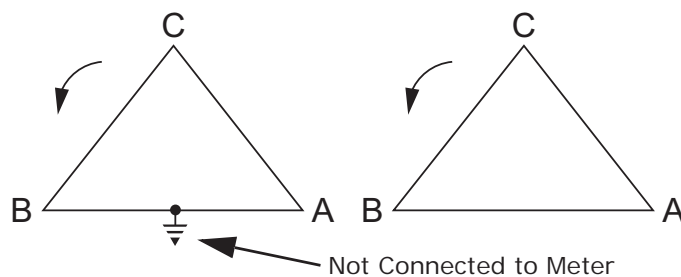

8. Service: Delta, 3-Wire with 2 PTs, 3 CTs

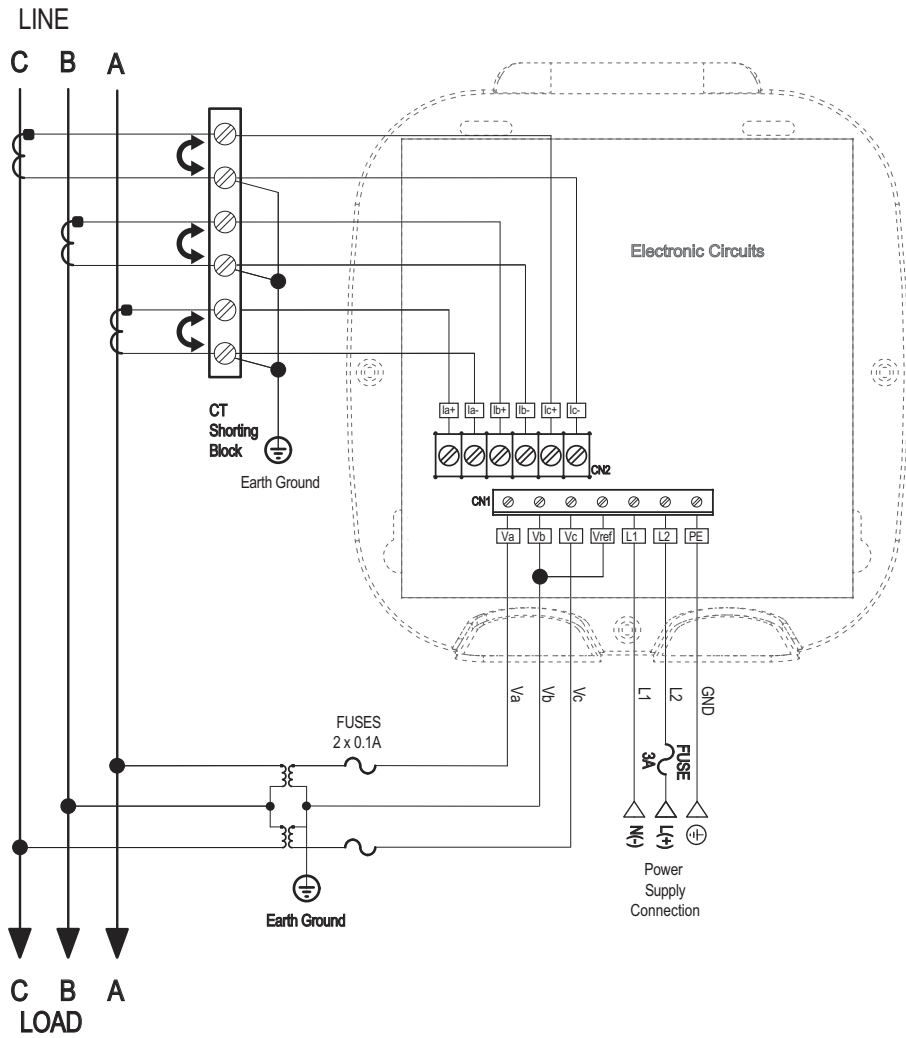

Select: "2 Ct dEL" (2 CT Delta) in Meter Programming setup.

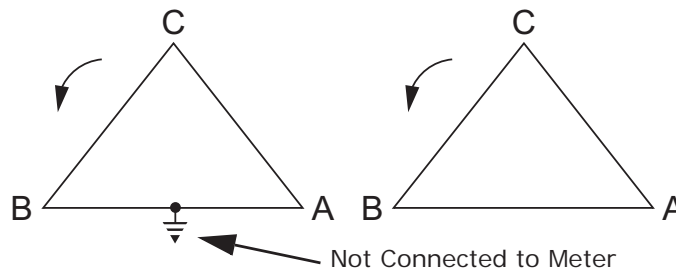

9. Service: Current Only Measurement (Three Phase)

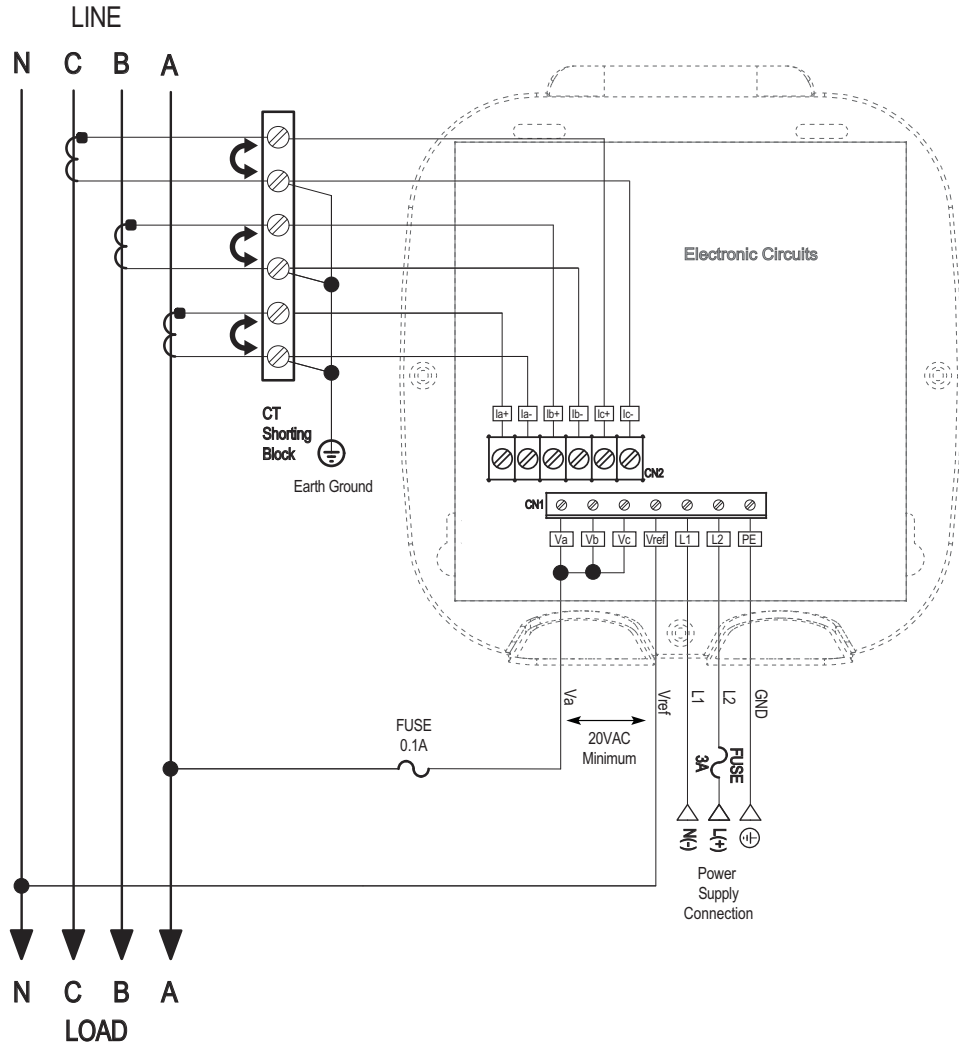

Select: "3 EL WYE" (3 Element Wye) in Meter Programming setup.

**NOTE:** Even if the meter is used for only Amp readings, the unit requires a Volts AN reference. Please make sure that the Voltage input is attached to the meter. AC Control Power can be used to provide the reference signal.

10. Service: Current Only Measurement (Dual Phase)

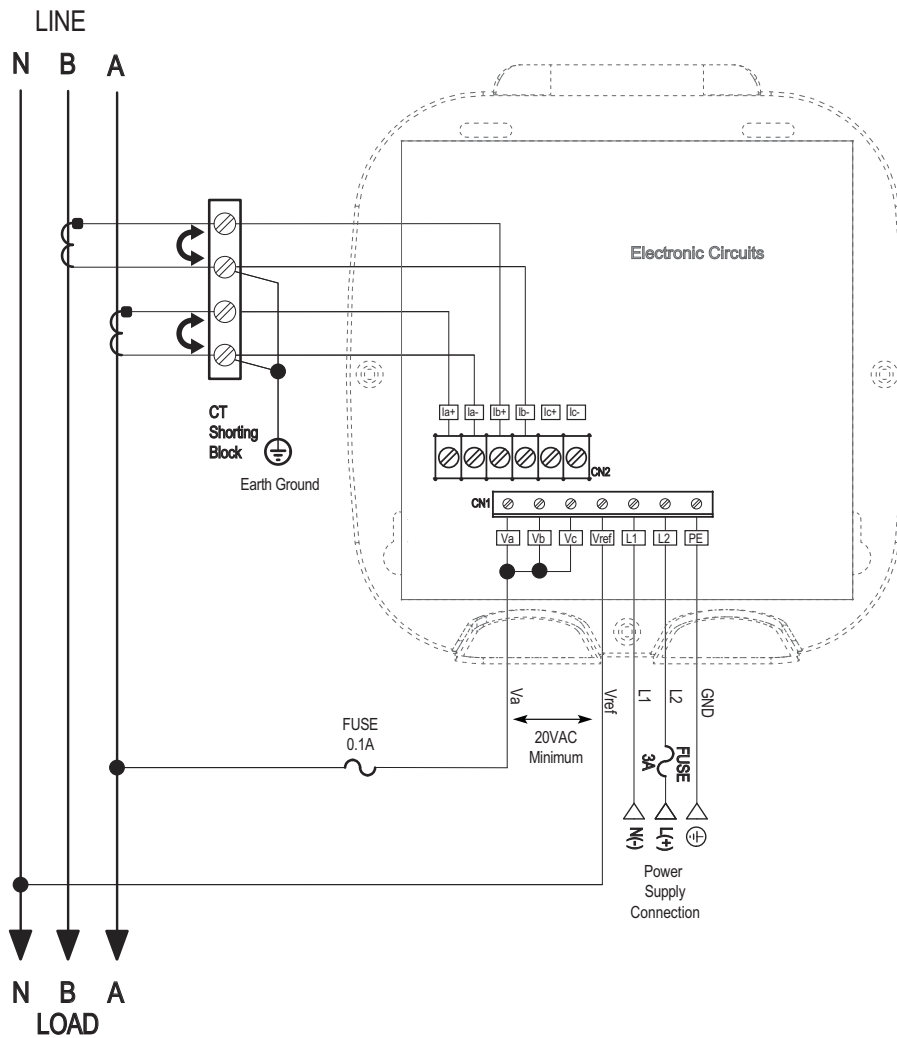

Select: "3 EL WYE" (3 Element Wye) in Meter Programming setup.

**NOTE:** Even if the meter is used for only Amp readings, the unit requires a Volts AN reference. Please make sure that the Voltage input is attached to the meter. AC Control Power can be used to provide the reference signal.

11. Service: Current Only Measurement (Single Phase)

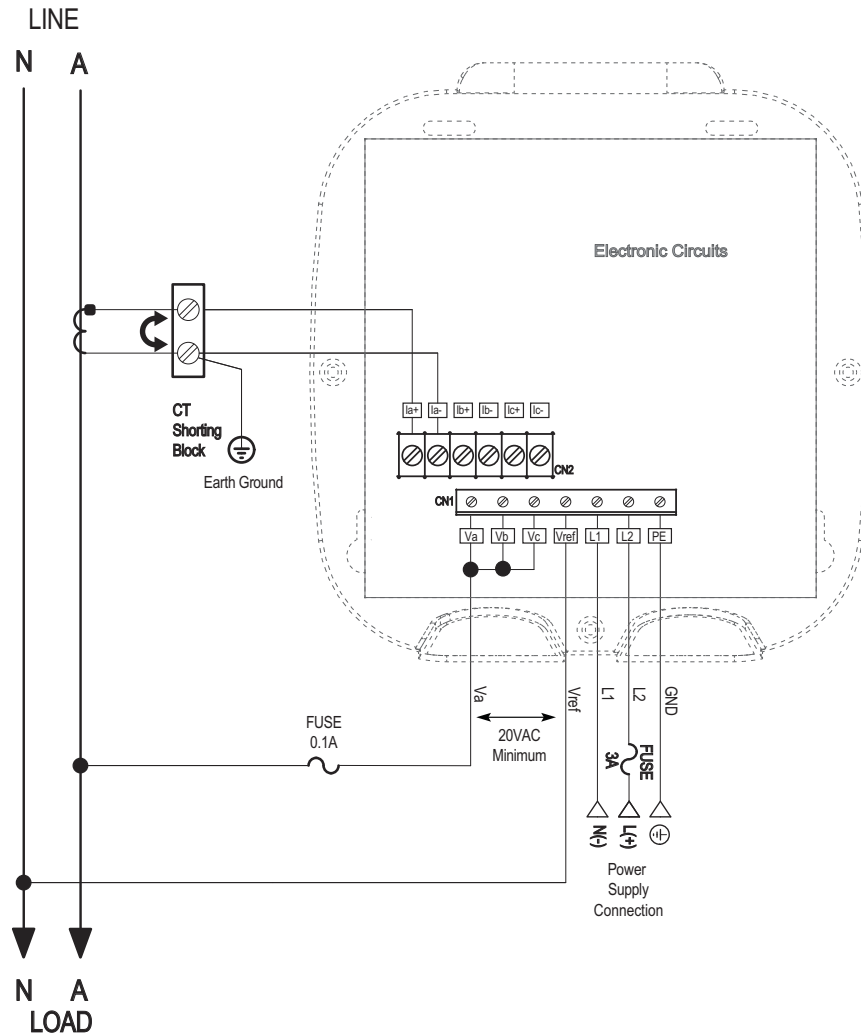

Select: "3 EL WYE" (3 Element Wye) in Meter Programming setup.

**NOTE:** Even if the meter is used for only Amp readings, the unit requires a Volts AN reference. Please make sure that the Voltage input is attached to the meter. AC Control Power can be used to provide the reference signal.

## 4.6: Extended Surge Protection for Substation Instrumentation

EIG offers a surge protector for applications with harsh electrical conditions. The surge protector is EI-MSB10-400 and it can be ordered from EIG'

The EI-MSB10-400 surge protector is designed to protect sensitive equipment from the damaging effects of lightning strikes and/or industrial switching surges in single phase AC networks up to 320VAC (L-N / L-G), and DC networks up to 400 VDC. The protectors are ideal for metering systems, RTUs, PLCs and protective relays. They are used specifically to extend the life and increase reliability of critical control apparatus.

For best protection, it is recommended to use two protectors. These will protect the instrument on the line inputs and on the reference input to ground. The protectors have LED indication to annunciate when the protection has worn out.

The EI-MSB10-400 is connected by wires in parallel with the network to be protected. It can be easily mounted on a wall or plate with self-adhesive tape.

See the wiring diagram below.

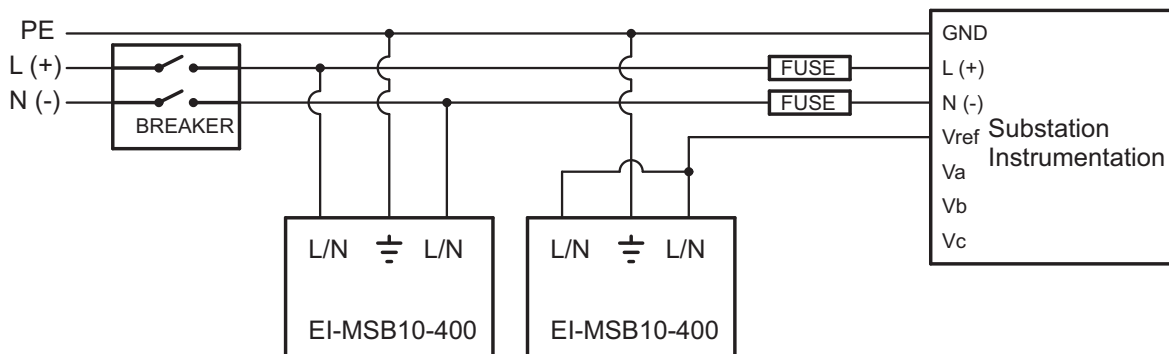

Figure 4.2: Wiring Schematic for Extended Surge Suppression  
Suitable for Substation Instrumentation

## 5: Communication Installation

### 5.1: Shark® 100S Communication

The Shark® 100S submeter provides two independent communication ports plus a KYZ pulse output. The first port, Com 1, is an IrDA Port, which uses Modbus ASCII. The second port, Com 2, provides RS485 or RJ45 Ethernet or WiFi Ethernet communication (see Chapter 6 for Ethernet communication).

#### 5.1.1: IrDA Port (Com 1)

The Com 1 IrDA port is located on the face of the submeter. The IrDA Port allows the unit to be set up and programmed with any device capable of IrDA communication, such as an IrDA-equipped laptop PC or a USB/IrDA wand (such as the USB to IrDA Adapter [CAB6490] described in Appendix E).

**IrDA port settings are**

Address: 1

Baud Rate: 57600 Baud

Protocol: Modbus ASCII



Figure 5.1: IrDA Communication

### 5.1.1.1: USB to IrDA Adapter

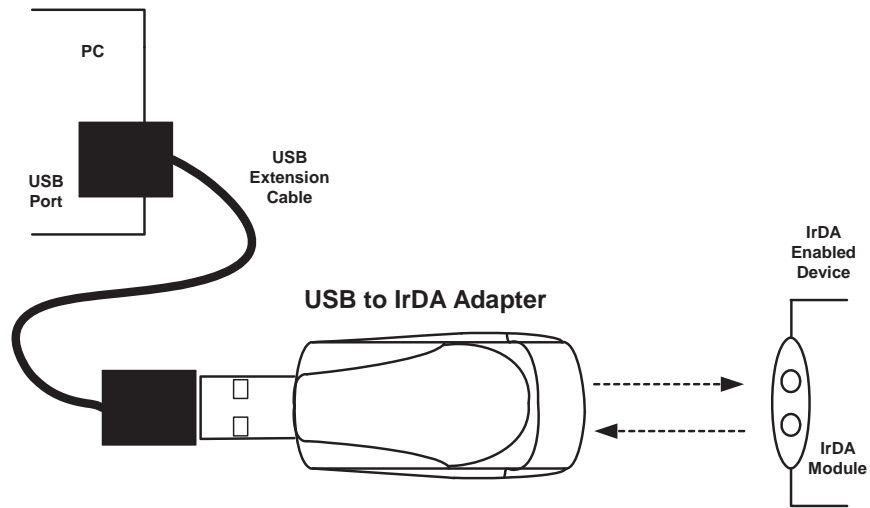

Figure 5.2: USB to IrDA Adapter

The USB to IrDA Adapter (CAB6490) enables IrDA wireless data communication through a standard USB port. The adapter is powered through the USB bus and does not require any external power adapter. The effective data transmission distance is 0 to .3 meters (approximately 1 foot).

The USB to IrDA Adapter enables wireless data transfer between a PC and the submeter. The adapter can also be used with other IrDA-compatible devices. The adapter is fully compatible with IrDA 1.1 and USB 1.1 specifications.

#### System Requirements

- IBM PC Pentium based computer
- 2 Gigabytes of RAM preferable
- Available USB port
- CD-ROM drive

See Appendix E for instructions on using the USB to IrDA Adapter. You can order CAB6490 Select Cables and Acces-  
sories from the list on the left side of the screen.



### 5.1.2: RS485 Communication Com 2 (485 Option)

The Shark® 100S submeter's RS485 port uses standard 2-Wire, half duplex architecture. The RS485 connector is located on the front of the meter, under the cover. A connection can easily be made to a Master device or to other slave devices, as shown below.



**WARNING!** During normal operation of the Shark® 100S meter, dangerous voltages flow through many parts of the meter, including: Terminals and any connected CTs (Current Transformers) and PTs (Potential Transformers), all I/O Modules (Inputs and Outputs) and their circuits. All Primary and Secondary circuits can, at times, produce lethal voltages and currents. Avoid contact with any current-carrying surfaces. **Before performing ANY work on the meter, make sure the meter is powered down and all connected circuits are de-energized.**

**AVERTISSEMENT!** Pendant le fonctionnement normal du compteur Shark® 100S des tensions dangereuses suivent de nombreuses pièces, notamment, les bornes et tous les transformateurs de courant branchés, les transformateurs de tension, toutes les sorties, les entrées et leurs circuits. Tous les circuits secondaires et primaires peuvent parfois produire des tensions de létal et des courants. Évitez le contact avec les surfaces sous tensions. **Avant de faire un travail dans le compteur, assurez-vous d'éteindre l'alimentation et de mettre tous les circuits branchés hors tension.**

**NOTE:** Care should be taken to connect + to + and - to - connections.

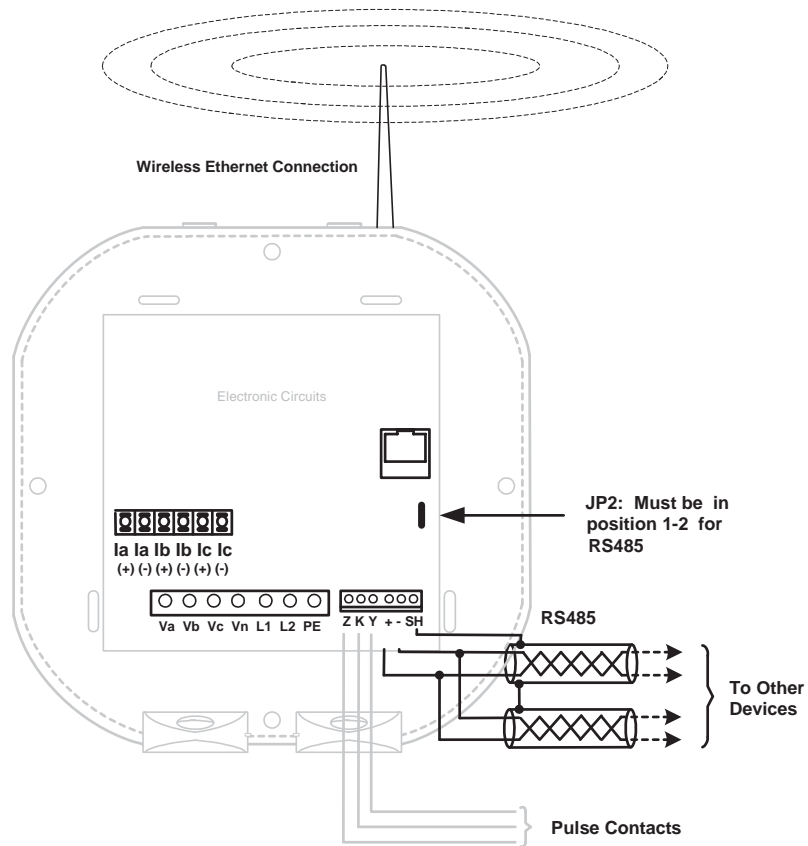

The Shark® 100S submeter's RS485 connection can be programmed with the buttons on the face of the meter or by using Communicator EXT™ software.

### Standard RS485 Port Settings

Address: 001 to 247

Baud Rate: 9600, 19200, 38400 or 57600 Baud

Protocol: Modbus RTU, Modbus ASCII, or DNP 3.0

\*\* The position of Jumper 2 (JP2) must be set for either RS485 or Ethernet communication. See the figure on the next page. You put the jumper on positions 2 and 3 for LAN (Ethernet) communication, and on 1 and 2 for RS485 communication.

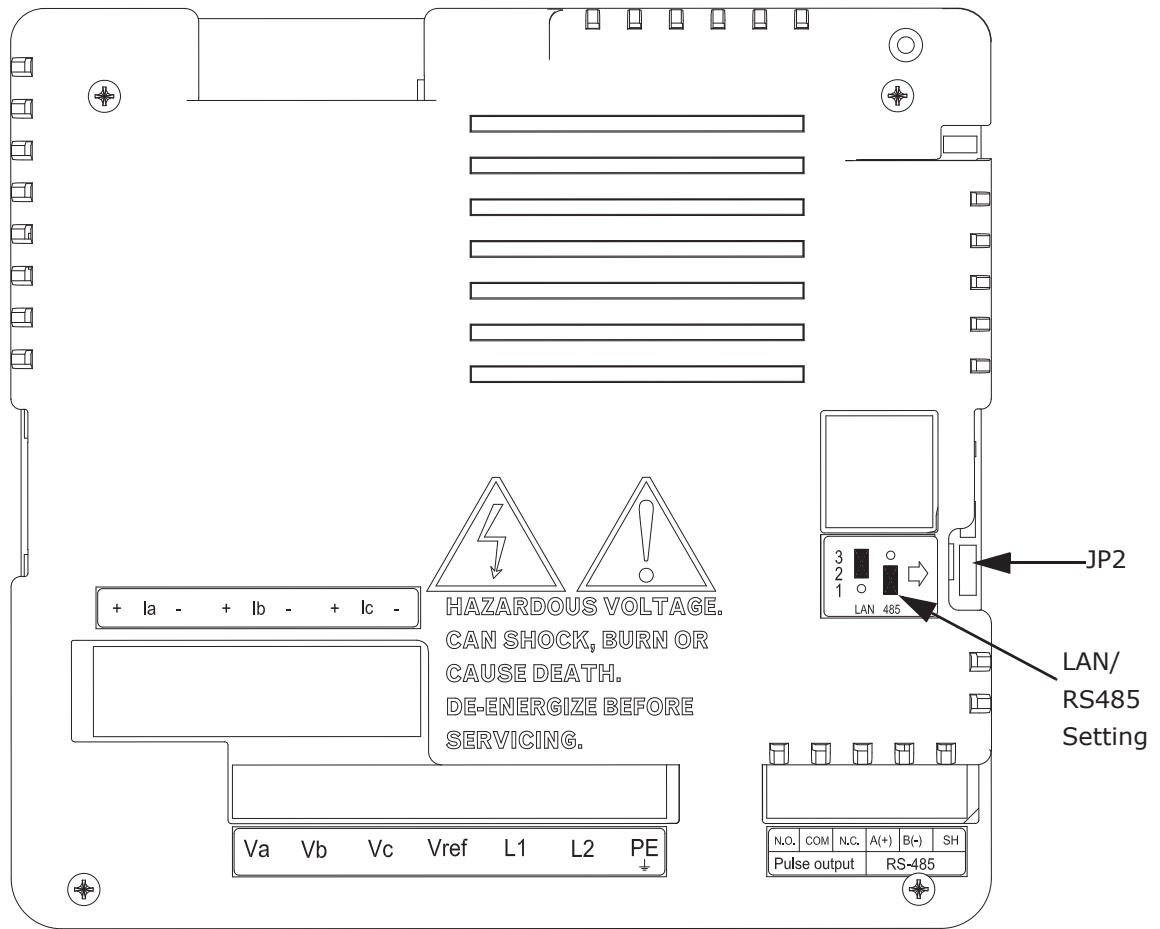

### 5.1.3: KYZ Output

The KYZ pulse output provides pulsing energy values that verify the submeter's readings and accuracy. The KYZ Pulse Output is located on the face of the meter, under the cover and just below the RS485 connection (see figure on the next page).



**WARNING!** During normal operation of the Shark® 100S meter, dangerous voltages flow through many parts of the meter, including: Terminals and any connected CTs (Current Transformers) and PTs (Potential Transformers), all I/O Modules (Inputs and Outputs) and their circuits. All Primary and Secondary circuits can, at times, produce lethal voltages and currents. Avoid contact with any current-carrying surfaces. **Before performing ANY work on the meter, make sure the meter is powered down and all connected circuits are de-energized.**

**AVERTISSEMENT!** Pendant le fonctionnement normal du compteur Shark® 100S des tensions dangereuses suivent de nombreuses pièces, notamment, les bornes et tous les transformateurs de courant branchés, les transformateurs de tension, toutes les sorties, les entrées et leurs circuits. Tous les circuits secondaires et primaires peuvent parfois produire des tensions de létal et des courants. Évitez le contact avec les surfaces sous tensions. **Avant de faire un travail dans le compteur, assurez-vous d'éteindre l'alimentation et de mettre tous les circuits branchés hors tension.**

See Section 2.2 for the KYZ output specifications; see Section 7.3.1 for pulse constants.

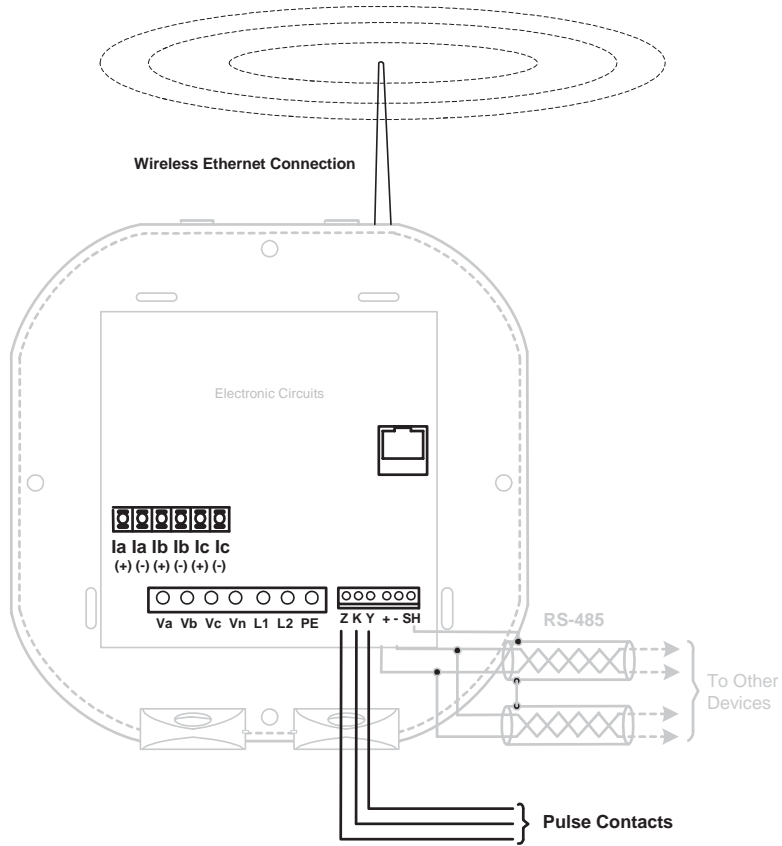

### 5.1.4: Ethernet Connection

In order to use the Shark® 100S submeter's Ethernet capability, the Ethernet Module must be installed in your meter, and the JP2 must be set to positions 2-3. You can use either wired Ethernet, or WiFi.

- For wired Ethernet, use Standard RJ45 10/100BaseT cable to connect to the Shark® 100S submeter. The RJ45 line is inserted into the RJ45 port of the meter.
- For Wi-Fi connections, make sure you have the correct antenna attached to the meter.



**WARNING!** During normal operation of the Shark® 100S meter, dangerous voltages flow through many parts of the meter, including: Terminals and any connected CTs (Current Transformers) and PTs (Potential Transformers), all I/O Modules (Inputs and Outputs) and their circuits. All Primary and Secondary circuits can, at times, produce lethal voltages and currents. Avoid contact with any current-carrying surfaces. **Before performing ANY work on the meter, make sure the meter is powered down and all connected circuits are de-energized.**

**AVERTISSEMENT!** Pendant le fonctionnement normal du compteur Shark® 100S des tensions dangereuses suivant de nombreuses pièces, notamment, les bornes et tous les transformateurs de courant branchés, les transformateurs de tension, toutes les sorties, les entrées et leurs circuits. Tous les circuits secondaires et primaires peuvent parfois produire des tensions de létal et des courants. Évitez le contact avec les surfaces sous tensions. **Avant de faire un travail dans le compteur, assurez-vous d'éteindre l'alimentation et de mettre tous les circuits branchés hors tension.**

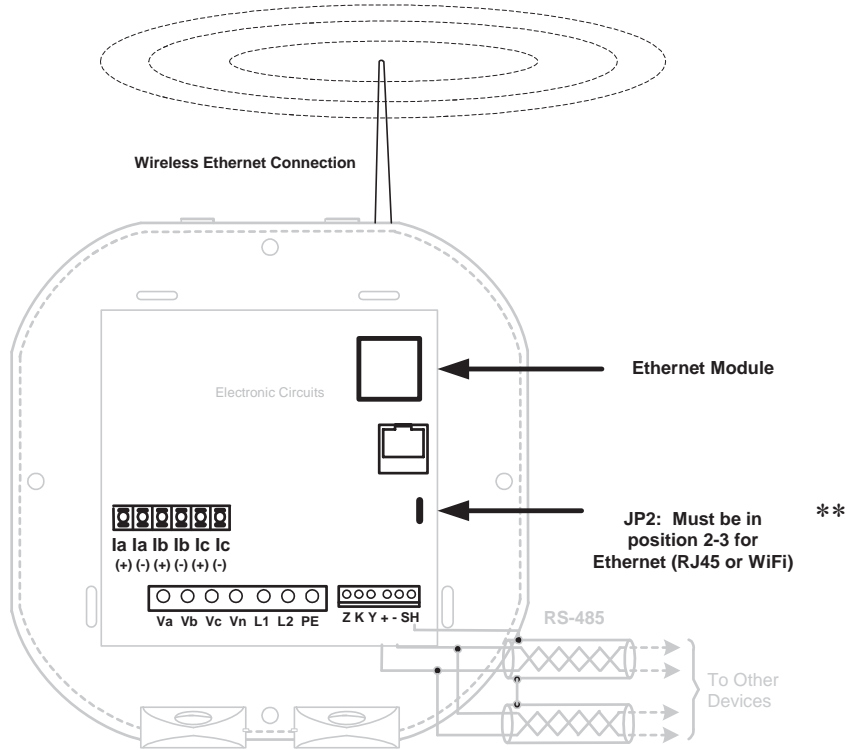

Refer to Chapter 6 for instructions on how to set up the Network Module.

\*\* See the JP2 figure and instructions on page 5-5.

## 5.2: Meter Communication and Programming Overview

Programming and communication can utilize the RS485 connection shown in Section 5.1.2 or the RJ45/WiFi connection shown in Section 5.1.4. Once a connection is established, Communicator EXT™ software can be used to program the meter and communicate to other devices.

### Meter Connection

To provide power to the meter, use one of the wiring diagrams in Chapter 4 or attach an Aux cable to GND, L(+) and N(-).

The RS485 cable attaches to SH, - and + as shown in Section 5.1.2.



### 5.2.1: How to Connect to the Submeter

1. Open Communicator EXT™ software.
2. Click the **Connect** icon in the Icon bar.

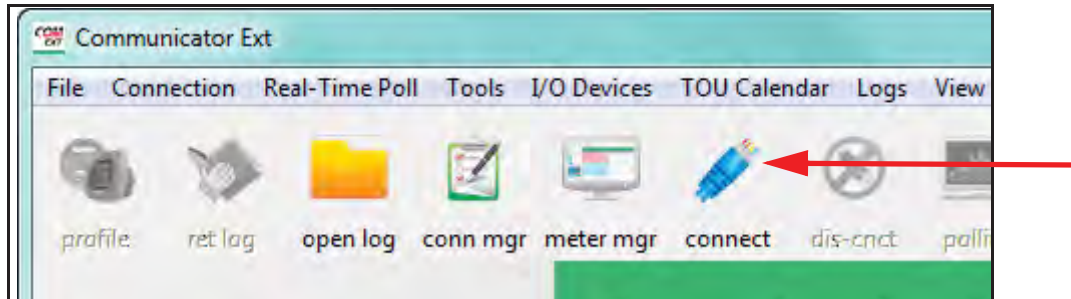

The Connect screen opens, showing the Initial settings. Make sure your settings are the same as those shown here, except for the IP Address field, which must be your device's IP address. The address shown here is the default Ethernet option address. **NOTE:** The settings you make will depend on whether you are connecting to the meter via Serial Port or Network. Use the pull-down menus to make any necessary changes.

Serial Port Connection

Network Connection

3. Click the **Connect** button on the screen.
 

**NOTE:** You may have to disconnect power, reconnect power and then click **Connect**.
4. The Device Status screen opens, confirming a connection. Click **OK**.
5. The Communicator EXT™ Main screen opens. Click the **Profile** icon in the Icon Bar.

6. You will see the Shark® 100S meter's Device Profile screen. The tabs at the top of the screen allow you to navigate between settings screens (see below).

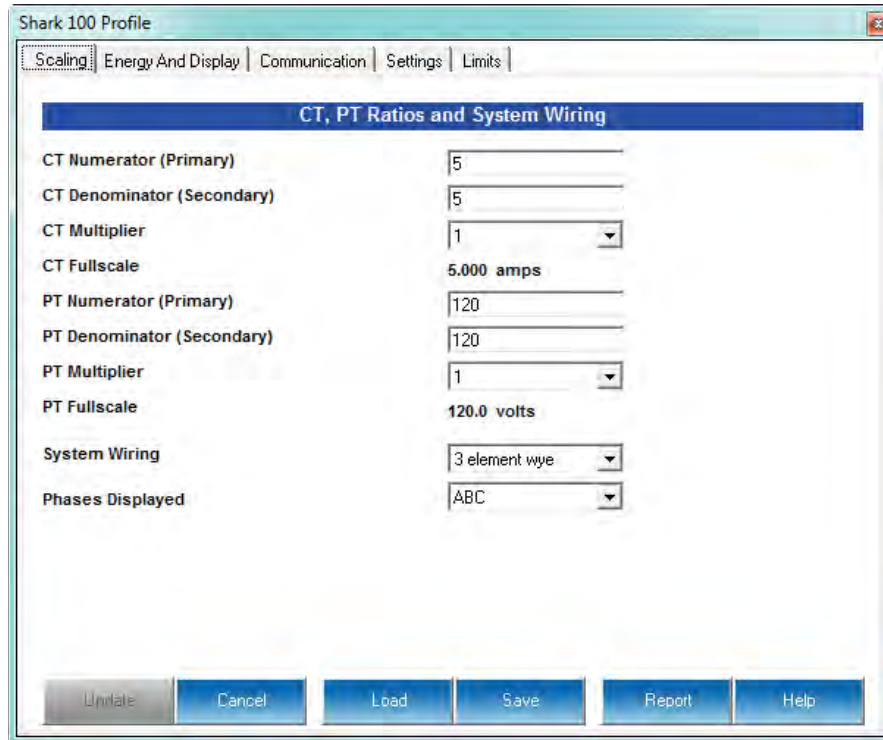

The screenshot shows the 'Shark 100 Profile' software window. At the top, there are five tabs: 'Scaling', 'Energy And Display', 'Communication', 'Settings', and 'Limits'. The 'Scaling' tab is currently selected. Below the tabs is a blue header bar with the text 'CT, PT Ratios and System Wiring'. The main area contains several settings:

CT Numerator (Primary)	5
CT Denominator (Secondary)	5
CT Multiplier	1
CT Fullscale	5,000 amps
PT Numerator (Primary)	120
PT Denominator (Secondary)	120
PT Multiplier	1
PT Fullscale	120.0 volts
System Wiring	3 element wye
Phases Displayed	ABC

At the bottom of the window, there are six buttons: 'Update', 'Cancel', 'Load', 'Save', 'Report', and 'Help'.

7. Click the **Communications** tab. You will see the following screen. Use this screen to enter communication settings for the meter's two on-board ports: the IrDA port (COM 1) and RS485 port (COM 2). Make any necessary changes to settings.

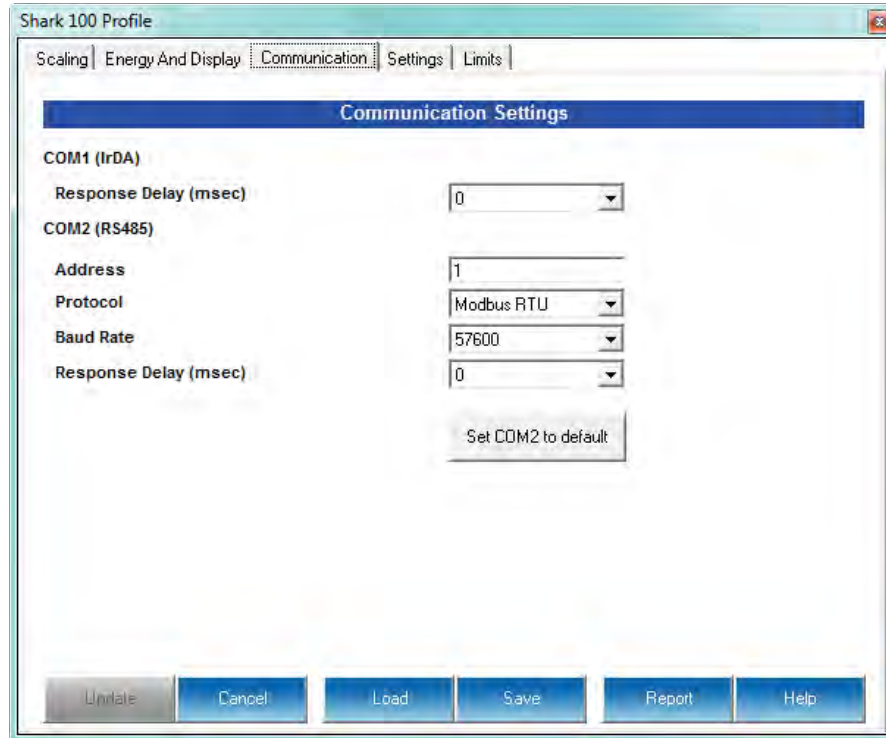

8. Valid Communication Settings are as follows:

COM1	(IrDA)
Response Delay	(0-750 msec)
COM2	(RS485)
Address	(1-247)
Protocol	(Modbus RTU, Modbus ASCII or DNP)
Baud Rate	(9600 to 57600)
Response Delay	(0-750 msec)

DNP Options for Voltage, Current, and Power - these fields allow you to choose Primary or Secondary Units for DNP, and to set custom scaling if you choose Primary. See Chapter 9 in the *Communicator EXT™ 4.0 and MeterManager EXT Software User Manual* for more information.

9. When changes are complete, click the **Update Device** button to send the new profile to the meter.

10. Click **Exit** to leave the Device Profile or click other menu items to change other aspects of the Device Profile (see following section for instructions).

### 5.2.2: Shark® 100S Submeter Device Profile Settings

**NOTE:** Only the basic Shark® 100S submeter Device Profile settings are explained in this manual. Refer to Chapter 9 in the *Communicator EXT™ 4.0 and MeterManager EXT Software User Manual* for detailed instructions on configuring all settings of the meter's Device Profile. You can view the manual online by clicking **Help>Contents** from the Communicator EXT™ Main screen.

#### CT, PT Ratios and System Hookup

The screenshot shows the 'Shark 100 Profile' window with the 'Settings' tab selected. The 'CT, PT Ratios and System Wiring' section contains the following fields and values:

Field	Value
CT Numerator (Primary)	5
CT Denominator (Secondary)	5
CT Multiplier	1
CT Fullscale	5.000 amps
PT Numerator (Primary)	120
PT Denominator (Secondary)	120
PT Multiplier	1
PT Fullscale	120.0 volts
System Wiring	3 element wye
Phases Displayed	ABC

At the bottom of the window, there are buttons for 'Unrate', 'Cancel', 'Load', 'Save', 'Report', and 'Help'.

The screen fields and acceptable entries are as follows:

#### CT Ratios

CT Numerator (Primary): 1 - 9999

CT Denominator (Secondary): 5 or 1 Amp

**NOTE:** This field is display only.

CT Multiplier: 1, 10 or 100

Current Full Scale: Calculations based on selections. Click **Recalculate** to see the result of changes.

### PT Ratios

PT Numerator (Primary): 1 - 9999

PT Denominator (Secondary): 40 - 600

PT Multiplier: 1, 10, 100, or 1000

Voltage Full Scale: Calculations based on selections. Click **Recalculate** to see the result of changes.

### System Wiring

3 Element Wye; 2.5 Element Wye; 2 CT Delta

### Phases Displayed

A, AB, or ABC

**NOTE:** Voltage Full Scale = PT Numerator x PT Multiplier

### Example:

A 14400/120 PT would be entered as:

PT Numerator: 1440

PT Denominator: 120

Multiplier: 10

This example would display a 14.40kV.

### Example CT Settings:

200/5 Amps: Set the Ct-n value for 200, Ct-Multiplier value for 1

800/5 Amps: Set the Ct-n value for 800, Ct-Multiplier value for 1

2,000/5 Amps: Set the Ct-n value for 2000, Ct-Multiplier value for 1

10,000/5 Amps: Set the Ct-n value for 1000, Ct-Multiplier value for 10

**Example PT Settings:**

277/277 Volts: Pt-n value is 277, Pt-d value is 277, Pt-Multiplier is 1

14,400/120 Volts: Pt-n value is 1440, Pt-d value is 120, Pt-Multiplier value is 10

138,000/69 Volts: Pt-n value is 1380, Pt-d value is 69, Pt-Multiplier value is 100

345,000/115 Volts: Pt-n value is 3450, Pt-d value is 115, Pt-Multiplier value is 100

345,000/69 Volts: Pt-n value is 345, Pt-d value is 69, Pt-Multiplier value is 1000

**NOTE:** Settings are the same for Wye and Delta configurations.

**Energy and Display**

The settings on this screen determine the display configuration of the meter's faceplate.

The screen fields and acceptable entries are as follows:

**Power and Energy Format**

Power Scale: Unit, kilo (k), Mega (M), or auto.

Energy Digits: 5, 6, 7, or 8

Energy Decimal Places: 0-6

Energy Scale: Unit, kilo (k), or Mega (M)

For Example: a reading for Digits: 8; Decimals: 3; Scale: k would be formatted:

00123.456k

Power Direction: View as Load or View as Generator

### **Demand Averaging**

Averaging Method: Block or Rolling

Interval (Minutes): 5, 15, 30, or 60

Sub Interval (if Rolling is selected): 1-4

### **Auto Scroll**

Click to set On or Off.

### **Display Configuration:**

Click Values to be displayed.

**NOTE:** You MUST select at least ONE.

**NOTE:** If incorrect values are entered on this screen the following message appears:

WARNING: Current, CT, PT and Energy Settings will cause invalid energy accumulator values.

Change the settings until the message disappears.



## Settings

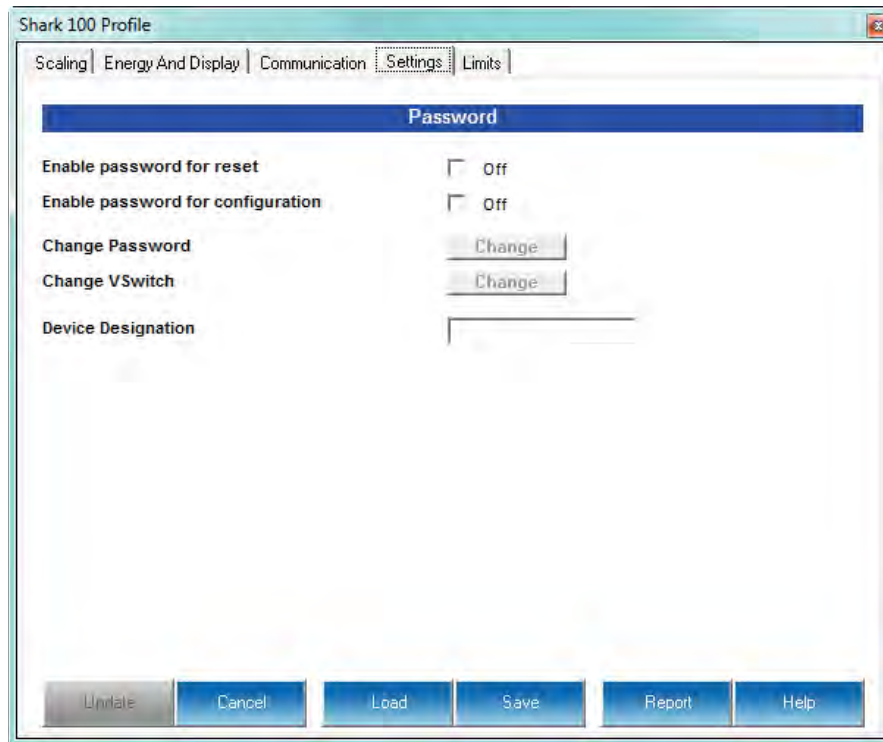

The screen fields are as follows:

### Password

**NOTE:** The meter is shipped with Password Disabled. There is NO DEFAULT PASSWORD.

Enable Password for Reset: click to Enable.

Enable Password for Configuration: click to Enable.

Change Password: click to Change.

Change VSwitch: click to Change (see Section 7.5 for instructions).

Device Designation: optional user-assigned label.



## Limits (V-Switch™ Key 4 Only)

Limit	Label	Above	Hysteresis	Below	Hysteresis
1	volts a-n	105.0%	105.0%	095.0%	095.0%
2	volts b-n	105.0%	105.0%	095.0%	095.0%
3	volts c-n	105.0%	105.0%	095.0%	095.0%
4	amps a	025.0%	025.0%	015.0%	015.0%
5	amps b	105.0%	105.0%	095.0%	095.0%
6	amps c	105.0%	105.0%	095.0%	095.0%
7	watts total	105.0%	105.0%	095.0%	095.0%
8	+watts avg	105.0%	105.0%	095.0%	095.0%

Limits are transition points used to divide acceptable and unacceptable measurements. When a value goes above or below the limit, an out-of-limit condition occurs. Once they are configured, you can view the out-of-Limits (or Alarm) conditions in the Limits Log or Limits Polling screen. You can also use Limits to trigger relays. See the *Communicator EXT™ 4.0 and MeterManager EXT Software User Manual* for details.

For up to 8 Limits, set:

Address: Modbus Address (1 based)

Label: Your designation for the limit

High Set Point: % of Full Scale

**Example:** 100% of 120VFS = 120V; 90% of 120V FS = 108V

Return Hysteresis: Point to go back in Limit

**Example:** High Set Point = 110% (Out of Limit at 132V); Return Hysteresis = 105%(Stay Out until 126V)

Low Set Point: % of Full Scale

Return Hysteresis: Point to go back in Limit.

Your settings appear in the Table at the bottom of the screen

**NOTES:** If Return Hysteresis is > High Set Point, the Limit is Disabled.

**IMPORTANT!** When you have finished making changes to the Device Profile, click **Update Device** to send the new Profile settings to the meter.

**NOTE:** Refer to Chapter 9 of the *Communicator EXT™ 4.0 and MeterManager EXT Software User Manual* for additional instructions on configuring the Shark® 100S submeter's settings.

## 6: Ethernet Configuration

### 6.1: Introduction

The Shark® 100S submeter has an option for a WiFi (Wireless) or RJ45 Ethernet connection. This option allows the submeter to be set up for use in a LAN (Local Area Network), using standard WiFi base stations. Configuration for these connections is easily accomplished through your PC using Telnet connections. Then you can access the submeter to perform meter functions directly through any computer on your LAN: the Shark® 100S meter does not need to be directly connected (wired) to these computers for it to be accessed.

This chapter outlines the procedures you use to set up the Shark® 100S submeter to function via its Ethernet configuration.

**IMPORTANT!** These instructions are for Shark® 100S meters that have a Reset button, located on the main board. You can easily tell whether or not your meter has a Reset button: open the front cover of the Shark® 100S meter. The Reset button is located at the top, right of the main board. Refer to the figure on the next page.

Some earlier versions of the Shark® 100S meter are not equipped with a Reset button. The instructions for Ethernet configuration are slightly different for these meters. If your meter does not have a Reset button, please call EIG's Technical Support department (at 516-334-0870) to obtain configuration instructions for your meter's Ethernet connection.



**WARNING!** During normal operation of the Shark® 100S meter, dangerous voltages flow through many parts of the meter, including: Terminals and any connected CTs (Current Transformers) and PTs (Potential Transformers), all I/O Modules (Inputs and Outputs) and their circuits. All Primary and Secondary circuits can, at times, produce lethal voltages and currents. Avoid contact with any current-carrying surfaces. **Before performing ANY work on the meter, make sure the meter is powered down and all connected circuits are de-energized.**

**AVERTISSEMENT!** Pendant le fonctionnement normal du compteur Shark® 100S des tensions dangereuses suivant de nombreuses pièces, notamment, les bornes et tous les transformateurs de courant branchés, les transformateurs de tension, toutes les sorties, les entrées et leurs circuits. Tous les circuits secondaires et primaires peu-

vent parfois produire des tensions de létal et des courants. Évitez le contact avec les surfaces sous tensions. **Avant de faire un travail dans le compteur, assurez-vous d'éteindre l'alimentation et de mettre tous les circuits branchés hors tension.**

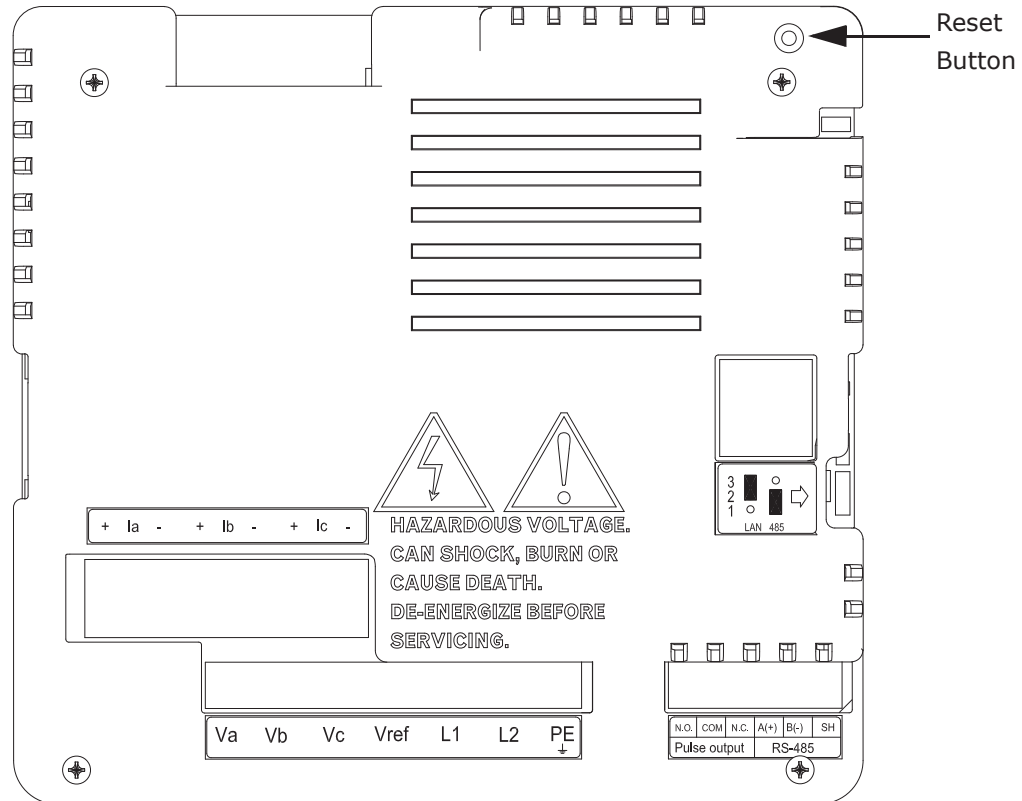

## 6.2: Factory Default Settings

The settings shown in Section 6.2.1 are the default settings for the Shark® 100S submeter: they are the settings programmed into your meter when it is shipped to you. You may need to modify some of these settings (for example, IP address) when you set up your Ethernet configuration.

### NOTES:

- You should **ONLY** change the settings that are shown in bold (Settings 1, 6, and 7). Settings 2, 3, and 4 must be the same as shown in Section 6.2.1. If they are not, reset them to the values shown in Section 6.2.1.
- If setting 3 is not CP0..! Defaults (In), the procedure for Network Module Hardware Initialization (Section 6.3.4) will not work.

### 6.2.1: Modbus/TCP to RTU Bridge Setup

#### 1) Network/IP Settings:

Network Mode.....Wired Only

IP Address .....10.0.0.1

Default Gateway ..... not set ---

Netmask .....255.255.255.0

#### 2) Serial & Mode Settings:

Protocol .....Modbus/RTU,Slave(s) attached

Serial Interface ..... 57600,8,N,1,RS232,CH1

#### 3) Modem/Configurable Pin Settings:

CP0..! Defaults (In) Wired    CP1..! GPIO (In)    CP2..! GPIO (In)

CP3..! GPIO (In)                    CP4..! GPIO (In)    CP5..! GPIO (In)

CP6..! GPIO (In)                    CP7..! GPIO (In)    CP8..! GPIO (In)

CP9..! GPIO (In)                    CP10..! GPIO (In)

RTS Output ..... Fixed High/Active

#### 4) Advanced Modbus Protocol settings:

Slave Addr/Unit Id Source .. Modbus/TCP header

Modbus Serial Broadcasts ...Disabled (Id=0 auto-mapped to 1)

MB/TCP Exception Codes ....Yes (return 00AH and 00BH)

Char, Message Timeout ..... 00050msec, 05000msec

#### 6) WLAN Settings:

WLAN.....Disabled, network:LTRX\_IBSS

Topology.....Adhoc, Country: US, Channel: 11

Security.....none

TX Data rate.....54 Mbps auto fallback

Power management.....Disabled

Soft AP Roaming.....N/A

Ad-hoc merging.....Enabled

WLAN Max failed packets....0

#### 7) Security Settings:

SNMP.....Enabled

SNMP Community Name.....public

Telnet Setup.....Enabled

TFTP Download.....Enabled

Port 77FEh.....Enabled

Enhanced Password.....Disabled

D)efault settings, S)ave, Q)uit without save

Select Command or parameter set (1..7) to change:

### 6.3: Configure Network Module

These procedures detail how to set up the Shark® 100S meter on the Network Module.

Only one person at a time can be logged into the network port. This eliminates the possibility of several people trying to configure the Ethernet interface simultaneously.

#### 6.3.1: Configuration Requirements

- You may want to consult your Network Administrator before performing these procedures, since some functions may be restricted to the Network Administrator.
- If you have only one Ethernet adapter (network card), the screen displays only that configuration. You will use this Ethernet adapter to access the Shark® 100S

meter's Network Module. You may have to configure the Ethernet adapter in order to use it with the Shark® 100S meter's Network Module, using the instructions in Section 6.4.2.

- If you have multiple Ethernet adapters (network cards) installed on your computer, you must choose, configure and use the correct one to access the Network Module.
- The Ethernet Adapter must be set up for point-to-point connection in order for it to connect to the Shark® 100S meter's Network module, as follows:

IP Address should be 10.0.0.2

Subnet Mask should be 255.255.255.0

These settings can be made in the Ethernet Adapter. Follow the procedure in Section 6.3.2.

### 6.3.2: Configuring the Ethernet Adapter

1. From the PC's Start Menu, select **Control Panel>Network Connections** or **Control Panel>Network and Internet>Network and Sharing Center**. You will see a screen showing your network connections. An example is shown below. Depending on your Operating system, the screen you see may look a bit different.

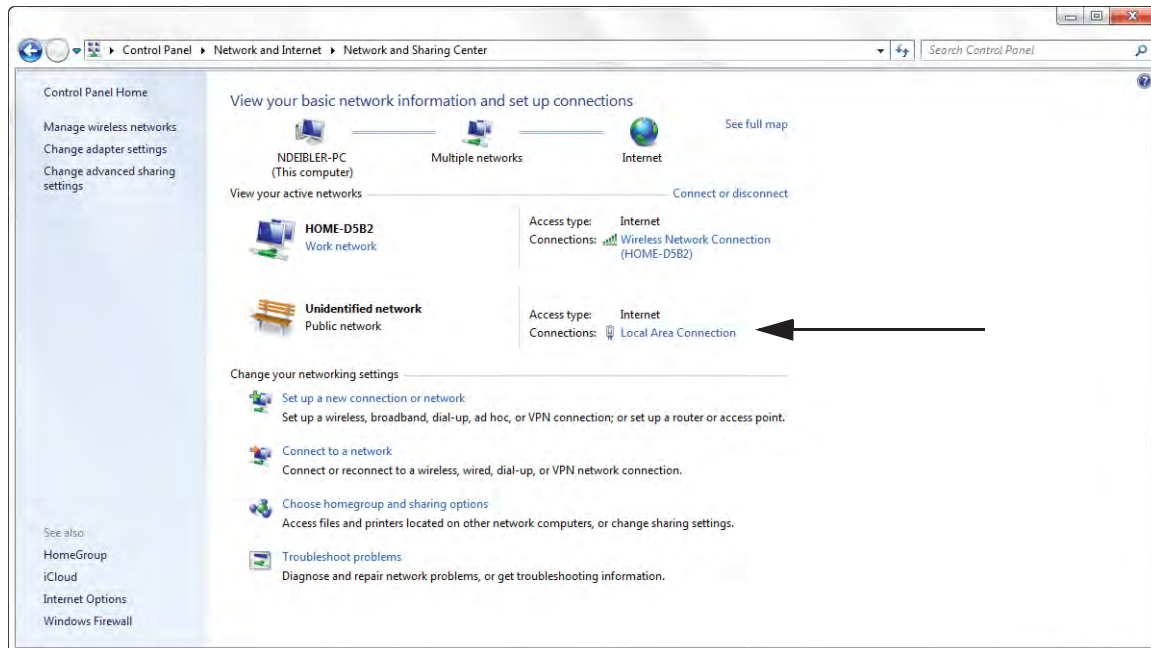

2. Right click on the Local Area Network connection you will be using to connect to the Shark® 100S submeter, and select Properties from the pull-down menu. You will see a screen similar to the one shown below.

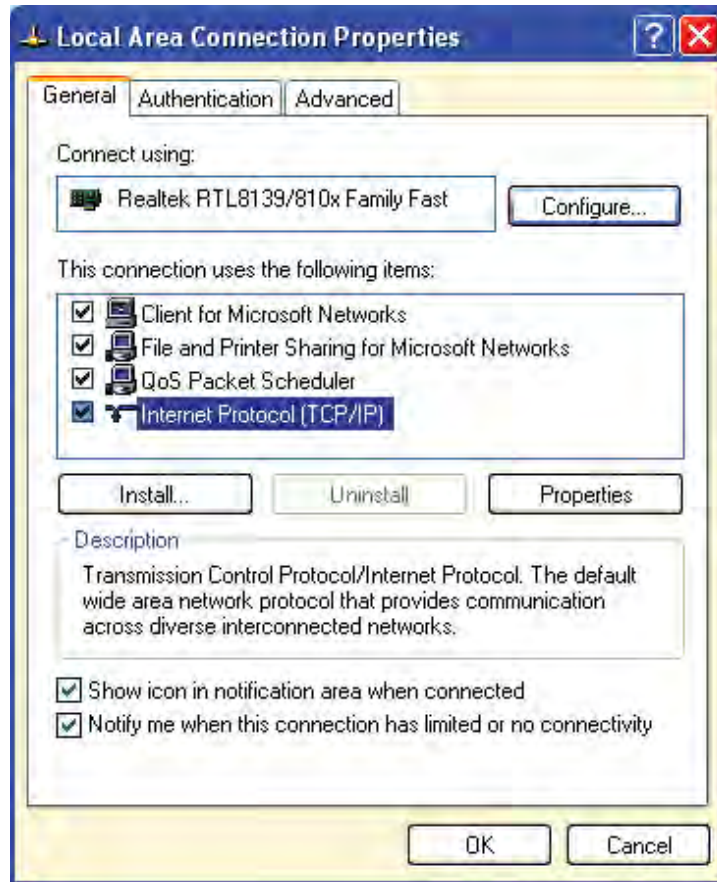

3. Select Internet Protocol [TCP/IP] from the middle of the screen and click the Properties button. You will see the screen shown on the next page.



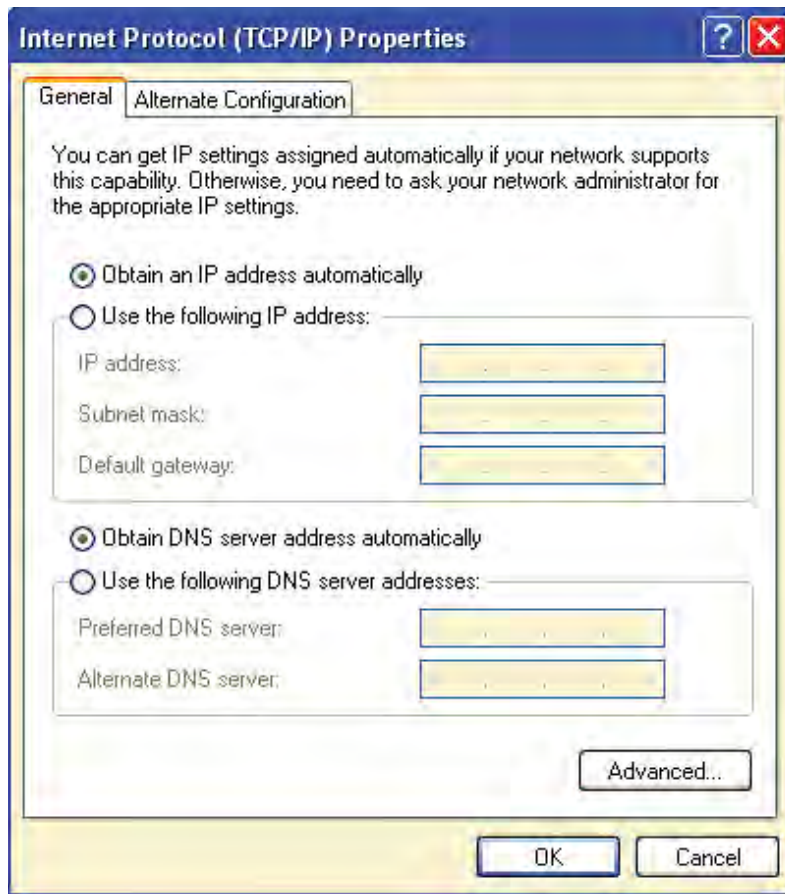

4. Click the Use the Following IP Address radio button. The screen changes to allow you to enter the IP Address and Subnet Mask.
  - a. Enter 10.0.0.2 in the IP Address field.
  - b. Enter 255.255.255.0 in the Subnet Mask field.
3. Click the **OK** button.
4. You can now close the Local Area Connection Properties and Network Connection windows.

### 6.3.3: Detailed Configuration Parameters

Certain parameters must be configured before the Ethernet interface can function on a network. The following procedure can be locally or remotely configured.

Use a Telnet connection to configure the unit over the network. The Ethernet interface's configuration is stored in meter memory and is retained without power. The configuration can be changed at any time. The Ethernet interface performs a reset after the configuration has been changed and stored.

**NOTE:** If your PC is running Windows 7, you need to enable Telnet before using it.

1. Open the Control Panel.
2. Select Programs and Features.
3. Select Turn Windows features on or off.
4. Check the box for Telnet Client.
5. Click OK. The Telnet client is now available.

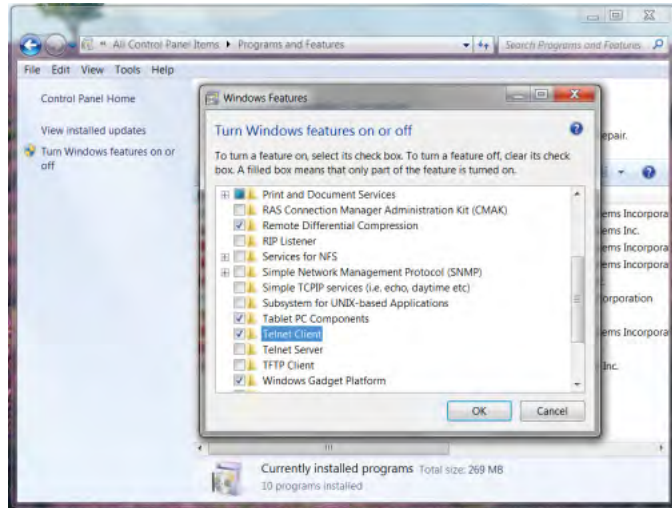

Establish a Telnet connection to port 9999:

1. From the Windows Start menu, click **Run** and type 'cmd'.
2. Click the **OK** button to bring up Windows's Command Prompt window.
3. In the Command Prompt window, type:
 

```
telnet 10.0.0.1 9999
```

 and press the **Enter** key.

**NOTE:** Be sure to include a space between the IP address and 9999.

You will see the following information.

```
C:\> Telnet 172.20.167.125
Modbus Bridge
MAC address 00204ACE7D10
Software version U3.3.25.0RC2 <130212>
Press Enter for Setup Mode
```

4. Press **Enter**.

5. You are now in Setup Mode - you can configure the parameters for the software you are using by entering one of the numbers on the Change Setup Menu, or you can confirm default values by pressing **Enter**. Be sure to store new configurations when you are finished. The Ethernet Interface will then perform a power reset and the Factory Default Settings will display again (refer to Section 6.2.1).

### 6.3.4: Setup Details

This section illustrates how each section of settings appears on the screen, when you select the setting number (1, 6, or 7).

**CAUTION!** Change Settings 1, 6, and 7 ONLY. Settings 2, 3, and 4 MUST be the same as shown in Section 6.2.1. If they are not, reset them to the values shown in Section 6.2.1, using the reset instructions in Section 6.4.

#### Network IP Settings Detail (1) (Set device with static IP Address.)

Network Mode: 0=Wired only, 1=Wireless Only <0> ? Key 1 and press Enter for WiFi mode.

IP Address <010> 192.<000> 168.<000> .<000> .<001> You can change the IP address in this setting.

Set Gateway IP Address <N> ? Y (If you want to change the Gateway address.)

Gateway IP Address : <192> .<168> .<000> .<001> (You can change the Gateway address in this setting.)

Set Netmask <N for default> <Y> ? Y (If you want to change the Netmask.)

<255> .<255> .<255> .<000> (You can change the Netmask in this setting.)

Change telnet config password <N> ? N

**WLAN Settings Detail (6)** (The settings shown are recommended by EIG for use with the Shark® 100S meter. You will only be able to access these settings if you have set Network Mode to "1" (to select Wireless mode) in the Network IP Settings Detail, shown previously.)

Topology: 0=Infrastructure, 1=Ad-Hoc <1> ? 0

Network Name: EIG\_SHARKS

Security suite: 0=none, 1=WEP, 2=WPA, 3=WPA2/802.11i <0> ? Enter the number of the encryption method are using, e.g., 3 for WPA2/802.11i.

- **If you select "1" (WEP), you will see the following settings:**

Authentication 0=open/none, 1=shared <0> ? (Enter 1 if you want the encryption key matched with a communication partner before messages are passed through.)

Encryption 1=WEP64, 2=WEP128 <1> 2

Change Key <N> Y

Display Key <N> N

Key Type 0=hex, 1=passphrase <0> 0

Enter Key:

You can manually enter 26 hexadecimal characters (required for 128-bit encryption) or you can use a WEP Key provider

WEP Key providers should note on their website that their encryption algorithm is for the Wired Equivalent Privacy portion of IEEE 802.11b/g.

WEP Key Provider Steps

1. Input 26 alphanumeric characters as your Passphrase.

**IMPORTANT!** Remember your Passphrase.

PASSPHRASE TO HEXADECIMAL WEP KEYS

Enter the passphrase below.

1009egbck001036ab

Generate keys

2. Click the Generate Keys button. Your Hexadecimal WEP Keys display.

PASSPHRASE TO HEXADECIMAL WEP KEYS

The passphrase 1009egbcke001306ab produces the following keys:

**64-BIT (40-BIT KEYS)**

1. AA43FB768D
2. 637D8DB9CE
3. AFDE50AF61
4. 0c35E73E25

**128-BIT (104-BIT) KEY**

041D7773D8B2C1D97BE9531DC

3. Enter the 128-bit Key.

TX Key Index <1> ? 1 (The WEP key used for transmissions - must be a value between 1 and 4.)

TX Data Rate: 0=fixed, 1=auto fallback <1> ? 1

TX Data rate: 0=1, 1=2, 2=5.5, 3=11, 4=18, 5=24, 6=36, 7=54 Mbps <7> ?  
Enter data transmission rate, e.g., 7 for 54Mbps.

Minimum Tx Data rate: 0=1, 1=2, 2=5.5, 3=11, 4=18, 5=24, 6=36,  
7=54 Mbps <0> ? 0

Enable Power management <N> ? Y

Enable Soft AP Roaming <N> ? N

Max Failed Packets (6-64, 255=disable) <6>? 6

- **If you select "2" (WPA), you will make the following settings:**

Change Key <N> Y

Display Key <N> N

Key Type 0=hex, 1=passphrase <0> 1

Enter Key: (The maximum length of the passphrase is 63 characters. EIG recommends using a passphrase of 20 characters or more for maximum security.)

Encryption: 0=TKIP, 1=TKIP+WEP <0> ? Set the type to the minimum required security level. The "+" sign indicates that the group (broadcast) encryption method is different from the pairwise (unicast) encryption (WEP and TKIP).

TX Data rate: 0=fixed, 1=auto fallback <1> ? 1

TX Data rate: 0=1, 1=2, 2=5.5, 3=11, 4=18, 5=24, 6=36, 7=54 Mbps <7> ?  
Enter data transmission rate, e.g., 7 for 54Mbps.

Minimum Tx Data rate: 0=1, 1=2, 2=5.5, 3=11, 4=18, 5=24, 6=36,  
7=54 Mbps <0> ? 0

Enable Power management <N> ? Y

Enable Soft AP Roaming <N> ? N

Max Failed Packets (6-64, 255=disable) <6>? 6

- **If you select "3" (WPA2/802.11i), you will make the following settings:**

Change Key <N> Y

Display Key <N> N

Key Type 0=hex, 1=passphrase <0> 1

Enter Key: (The maximum length of the passphrase is 63 characters. EIG recommends using a passphrase of 20 characters or more for maximum security.)

Encryption: 0=CCMP, 1=CCMP+TKIP, 2=CCMP+WEP, 3=TKIP, 4=TKIP+WEP  
<3> ? (Set the type to the minimum required security level. The "+" sign indicates that the group (broadcast) encryption method is different from the pair-

wise (unicast) encryption. For example, for CCMP+TKIP, CCMP is the pairwise encryption and TKIP is the group encryption. CCMP is the default for WPA2.)

TX Data rate: 0=fixed, 1=auto fallback <1> ? 1

TX Data rate: 0=1, 1=2, 2=5.5, 3=11, 4=18, 5=24, 6=36, 7=54 Mbps <7> ?  
Enter data transmission rate, e.g., 7 for 54Mbps.

Minimum Tx Data rate: 0=1, 1=2, 2=5.5, 3=11, 4=18, 5=24, 6=36,  
7=54 Mbps <0> ? 0

Enable Power management <N> ? Y

Enable Soft AP Roaming <N> ? N

Max Failed Packets (6-64, 255=disable) <6>? 6

### Security Settings (7)

Disable SNMP <N> ? N

SNMP Community Name <public>: (You can enter an SNMP community name here.)

Disable Telnet Setup <N> ? N (If you change this setting to Y, you will not be able to use Telnet to re-configure the Network card once you save the settings, without resetting the Network card, as shown in Section 6.4. However, you may want to disable Telnet setup and Port 77FEh to prevent users from accessing the setup from the network.)

Disable TFTP Firmware Update <N> ? N

Disable Port 77FEh <N> ? N (For security purposes, you may want to disable Telnet setup and Port 77FEh to prevent users from accessing the setup from the network.)

Enable Enhanced Password <N> ? N

Exiting the screen

**CAUTION!** DO NOT PRESS 'D': that will restore the Default Settings.

**Press 'S' to Save the settings you've entered.**

## 6.4: Network Module Hardware Initialization

If you don't know your current Network Module settings, or if the settings are lost, you can use this method to initialize the hardware with known settings you can then work with.

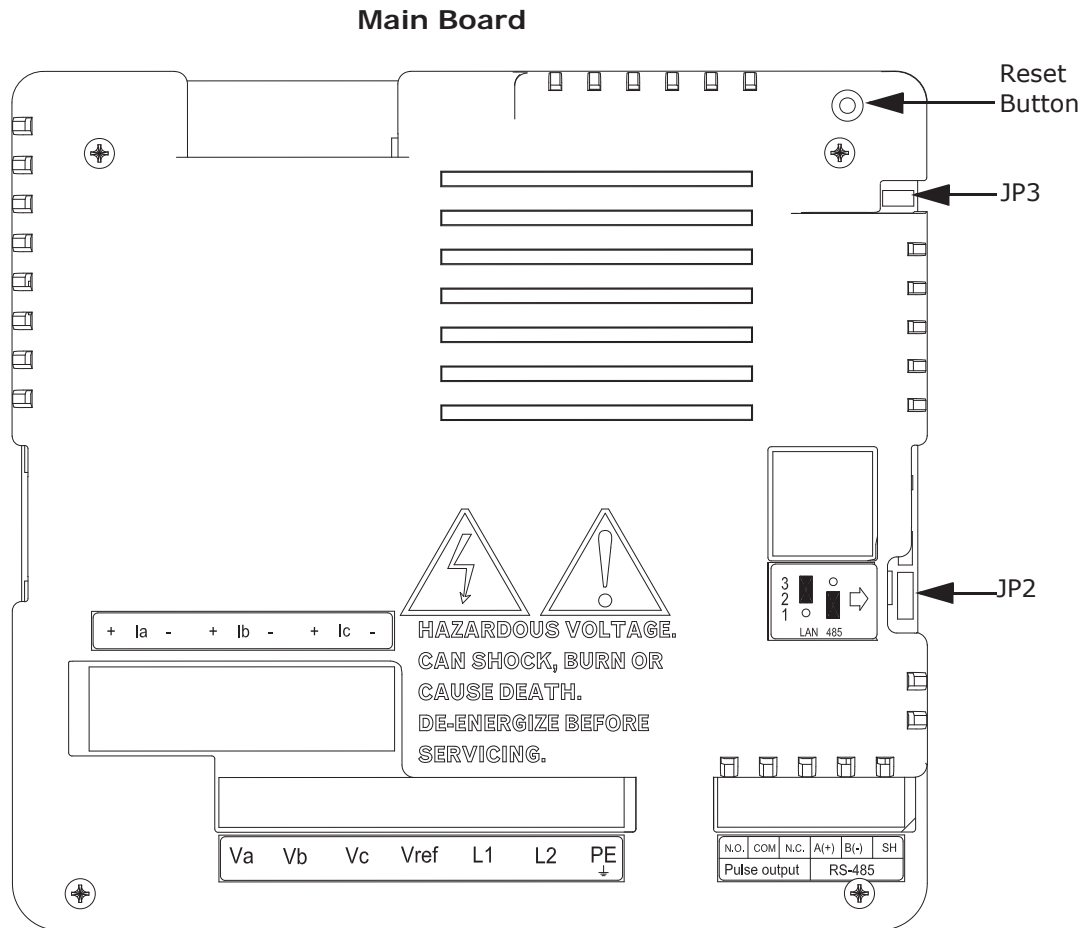

**WARNING!** During normal operation of the Shark® 100S meter, dangerous voltages flow through many parts of the meter, including: Terminals and any connected CTs (Current Transformers) and PTs (Potential Transformers), all I/O Modules (Inputs and Outputs) and their circuits. All Primary and Secondary circuits can, at times, produce lethal voltages and currents. Avoid contact with any current-carrying surfaces. **Before performing ANY work on the meter, make sure the meter is powered down and all connected circuits are de-energized.**

**AVERTISSEMENT!** Pendant le fonctionnement normal du compteur Shark® 100S des tensions dangereuses suivent de nombreuses pièces, notamment, les bornes et



tous les transformateurs de courant branchés, les transformateurs de tension, toutes les sorties, les entrées et leurs circuits. Tous les circuits secondaires et primaires peuvent parfois produire des tensions de légal et des courants. Évitez le contact avec les surfaces sous tensions. **Avant de faire un travail dans le compteur, assurez-vous d'éteindre l'alimentation et de mettre tous les circuits branchés hors tension.**

1. Place a shorting block on JP3 and press the **Reset** button on the main board.  
**NOTE:** JP3 is located on the right hand side, upper corner of the main board. The shorting block can be "borrowed" from JP2, located at the middle, right hand side. See the figure shown on the previous page.
2. After you press the **Reset** button, move the jumper back to JP2.
3. Make sure your settings are the same as those in Section 6.2.1. Follow the steps in Section 6.3 to configure the Network Module.

## 7: Using the Submeter

### 7.1: Introduction

The Shark® 100S submeter can be configured and a variety of functions can be accomplished by using the Elements and the Buttons on the submeter face. This chapter reviews front panel navigation. See Appendix A for complete Navigation maps.

#### 7.1.1: Understanding Submeter Face Elements

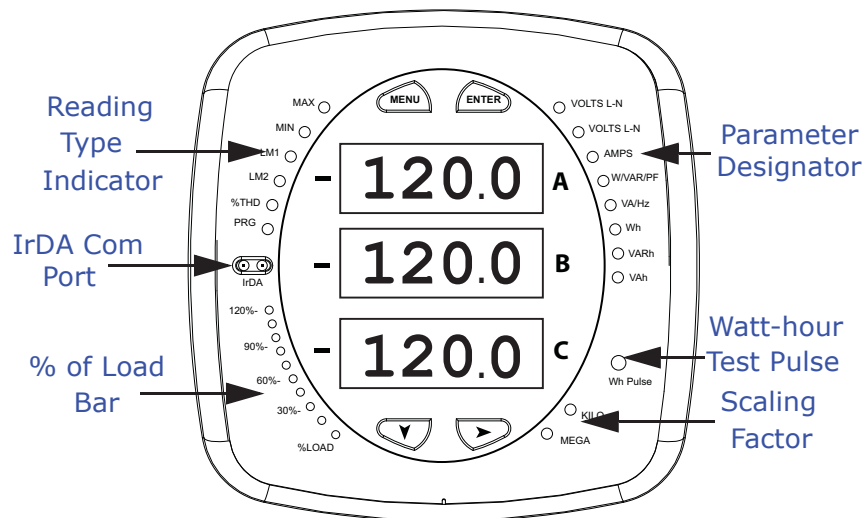

Figure 7.1: Faceplate with Elements

The meter face features the following elements:

- Reading Type Indicator: e.g., Max
- Parameter Designator: e.g., Volts L-N
- Watt-Hour Test Pulse: Energy pulse output to test accuracy
- Scaling Factor: Kilo or Mega multiplier of displayed readings
- % of Load Bar: Graphic Display of Amps as % of the Load (Refer to Section 7.3 for additional information.)

- IrDA Communication Port: Com 1 port for wireless communication

### 7.1.2: Understanding Submeter Face Buttons

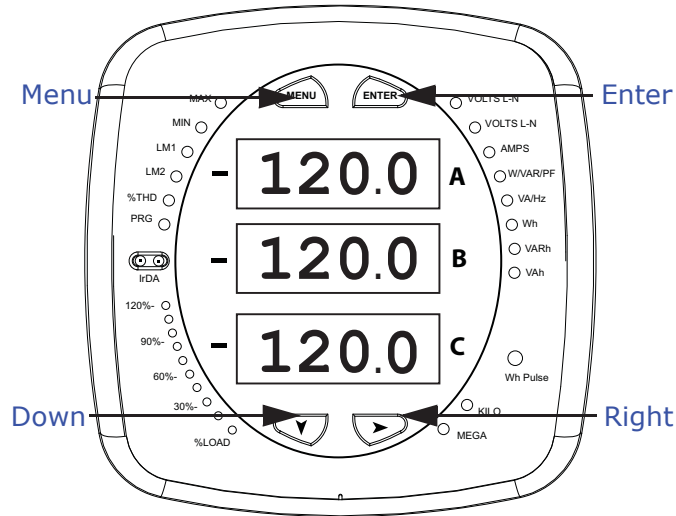

Figure 7.2: Faceplate with Buttons

The meter face has **Menu**, **Enter**, **Down** and **Right** buttons, which let you perform the following functions:

- View Meter Information
- Enter Display Modes
- Configure Parameters (may be Password Protected)
- Perform Resets (may be Password Protected)
- Perform LED Checks
- Change Settings
- View Parameter Values
- Scroll Parameter Values
- View Limit States (V-4)

## 7.2: Using the Front Panel

You can access four modes using the Shark® 100S submeter's front panel buttons:

- Operating mode (Default)
- Reset mode
- Configuration mode
- Information mode - Information mode displays a sequence of screens that show model information, such as Frequency, Amps, V-Switch, etc.

Use the **Menu**, **Enter**, **Down** and **Right** buttons to navigate through each mode and its related screens.

### NOTES:

- See Appendix A for the complete display mode Navigation maps.
- The meter can also be configured using software; see Chapter 5 and the *Communicator EXT™ 4.0 and MeterManager EXT Software User Manual* for instructions.

### 7.2.1: Understanding Startup and Default Displays

Upon Power Up, the meter displays a sequence of screens:

- Lamp Test screen where all LEDs are lit
- Lamp Test screen where all digits are lit
- Firmware screen showing build number
- Error screen (if an error exists)

After startup, if auto-scrolling is enabled, the Shark® 100S meter scrolls the parameter readings on the right side of the front panel. The Kilo or Mega LED lights, showing the scale for the Wh, VARh and VAh readings. Figure 7.3 shows an example of a Wh reading.

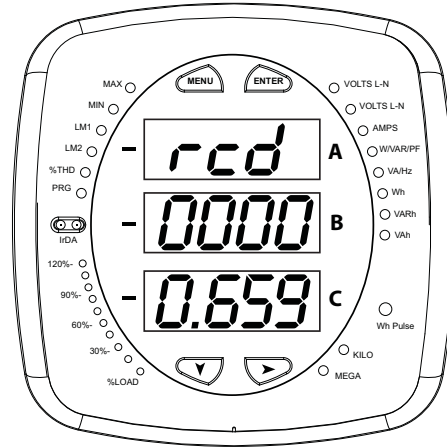

Figure 7.3: Display Showing Watt-hr Reading

The Shark® 100S meter continues to provide scrolling readings until one of the buttons on the front panel is pressed, causing the meter to enter one of the other Modes.

### 7.2.2: Using the Main Menu

1. Press the **Menu** button. The Main Menu screen appears.

- The Reset (rSt) mode appears in the A window. Use the Down button to scroll, causing the Configuration (CFG), Operating (OPr), and Information (InFo) modes to move to the A window.
- The mode that is currently flashing in the A window is the “Active” mode, which means it is the mode that can be configured.

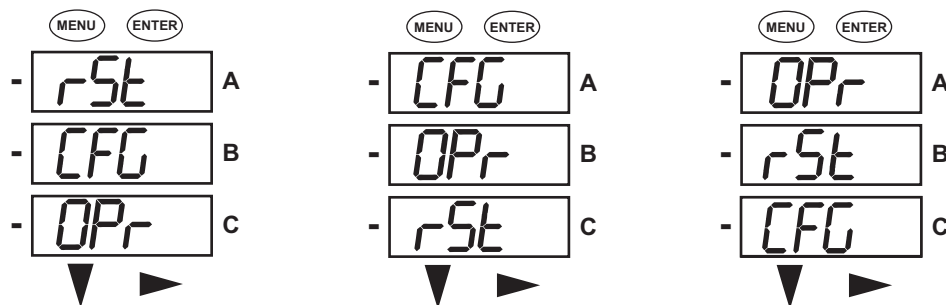

For example: Press Down Once - CFG moves to A window. Press Down Once - OPr moves to A window.

2. Press the **Enter** button from the Main Menu to view the Parameters screen for the mode that is currently active.

### 7.2.3: Using Reset Mode

1. Press the Enter button while rSt is in the A window.

The "rSt (Reset) ALL? no" screen appears.

- If you press the **Enter** button again, the Main Menu appears, with the next mode in the A window. (The **Down** button does not affect this screen.)
- If you press the **Right** button, the "rSt ALL? YES" screen appears. Press **Enter** to perform a reset.

**CAUTION! All Max and Min values will be reset.**

**NOTE:** If Password protection is enabled for reset, you must enter the four digit password before you can reset the meter (see Chapter 6 for information on Password protection). To enter a password, follow the instructions in Section 6.2.4.

2. Once you have performed a reset, the screen displays "rSt ALL donE" and then resumes auto-scrolling parameters.

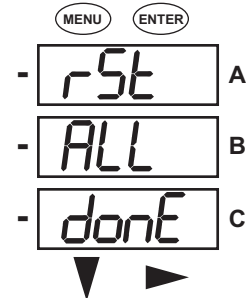
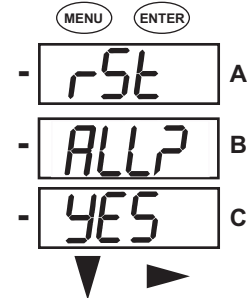
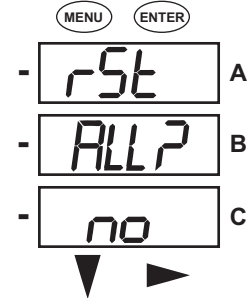

### 7.2.4: Entering a Password

If Password protection has been enabled in the software for reset and/or configuration (see Chapter 5 for more information), a screen appears requesting a password when you try to reset the meter and/or configure settings through the front panel.

- PASS appears in the A window and 4 dashes appear in the B window. The leftmost dash is flashing.
1. Press the **Down** button to scroll numbers from 0 to 9 for the flashing dash. When the correct number appears for that dash, use the **Right** button to move to the next dash.

**Example:** The left screen, below, shows four dashes. The right screen shows the display after the first two digits of the password have been entered.

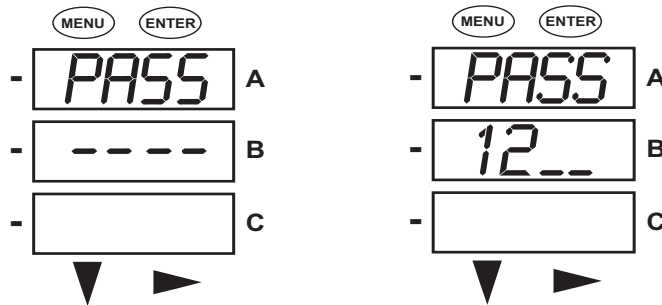

2. When all 4 digits of the password have been selected, press the **Enter** button.
  - If you are in Reset Mode and you enter the correct password, "rSt ALL donE" appears and the screen resumes auto-scrolling parameters.
  - If you are in Configuration Mode and you enter the correct password, the display returns to the screen that required a password.
  - If you enter an incorrect password, "PASS ---- FAIL" appears and:
    - The previous screen is re-displayed, if you are in Reset Mode.
    - The previous Operating mode screen is re-displayed, if you are in Configuration mode.

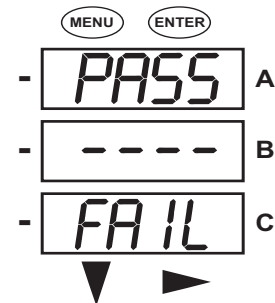

### 7.2.5: Using Configuration Mode

Configuration mode follows Reset: Energy on the Main Menu.

#### To access Configuration mode

1. Press the **Menu** button while the meter is auto-scrolling parameters.
2. Press the **Down** button until the Configuration Mode option (CFG) is in the A window.
3. Press the **Enter** button. The Configuration Parameters screen appears.
4. Press the **Down** button to scroll through the configuration parameters: Scroll (SCrL), CT, PT, Connection (Cnct) and Port. The parameter currently 'Active,' i.e., configurable, flashes in the A window.
5. Press the **Enter** button to access the Setting screen for the currently active parameter.

**NOTE:** You can use the **Enter** button to scroll through all of the Configuration parameters and their Setting screens, in order.

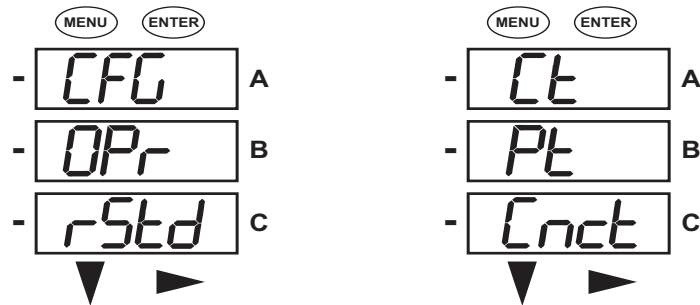

Press **Enter** when CFG is in A window - Parameter screen appears -

Press **Down**- Press **Enter** when

Parameter you want is in A window

6. The parameter screen appears, showing the current settings. To change the settings:

- Use either the **Down** button or the **Right** button to select an option.



- To enter a number value, use the **Down** button to select the number value for a digit and the **Right** button to move to the next digit.

**NOTE:** When you try to change the current setting and Password protection is enabled for the meter, the Password screen appears. See Section 7.2.4 for instructions on entering a password.

7. Once you have entered the new setting, press the **Menu** button twice.

8. The Store ALL YES screen appears. You can either:

- Press the **Enter** button to save the new setting.
- Press the **Right** button to access the Store ALL no screen; then press the **Enter** button to cancel the Save.

9. If you have saved the settings, the Store ALL done screen appears and the meter resets.

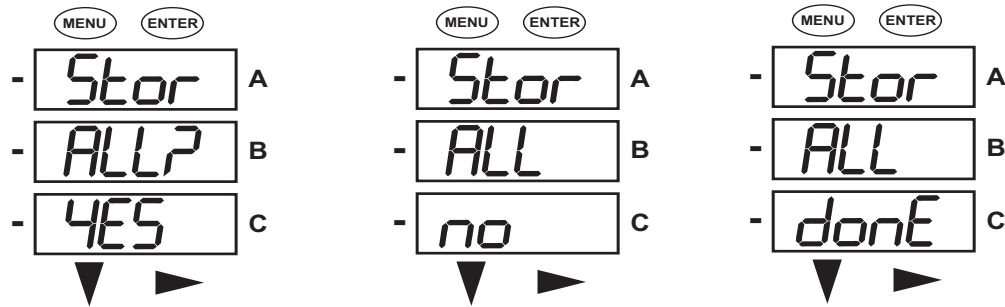

Press the **Enter** button to save the settings. Press the **Right** button for Stor All no screen.

Press the **Enter** button to Cancel the Save.

The settings have been saved.

### 7.2.5.1: Configuring the Scroll Feature

When in Auto Scroll mode, the meter performs a scrolling display, showing each parameter for 7 seconds, with a 1 second pause between parameters. The parameters that the meter displays are determined by the following conditions:

- They have been selected through software (refer to the *Communicator EXT™ 4.0 and MeterManager EXT Software User Manual* for instructions).
- They are enabled by the installed V-Switch™ key. Refer to Section 7.5 for information on V-Switch™ keys.

**To enable or disable Auto-scrolling:**

1. Press the **Enter** button when SCrL is in the A window. The Scroll YES screen appears.
2. Press either the **Right** or **Down** button if you want to access the Scroll no screen. To return to the Scroll YES screen, press either button.
3. Press the **Enter** button on either the Scroll YES screen (to enable auto-scrolling) or the Scroll no screen (to disable auto-scrolling).
4. The CT- n screen appears (this is the next Configuration mode parameter).

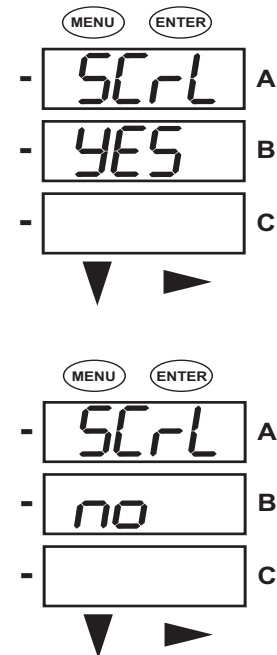

**NOTES:**

- To exit the screen without changing scrolling options, press the **Menu** button.
- To return to the Main Menu screen, press the **Menu** button twice.
- To return to the scrolling (or non-scrolling) parameters display, press the **Menu** button three times.

### 7.2.5.2: Configuring CT Setting

The CT Setting has three parts: Ct-n (numerator), Ct-d (denominator), and Ct-S (scaling).

1. Press the **Enter** button when Ct is in the A window. The Ct-n screen appears. You can either:

- Change the value for the CT numerator.
- Access one of the other CT screens by pressing the **Enter** button: press **Enter** once to access the Ct-d screen, twice to access the Ct-S screen.

**NOTE:** The Ct-d screen is preset to a 5 amp or 1 amp value at the factory and cannot be changed.

a. To change the value for the CT numerator:

From the Ct-n screen:

- Use the Down button to select the number value for a digit.
- Use the Right button to move to the next digit.

b. To change the value for CT scaling

From the Ct-S screen:

Use the **Right** button or the **Down** button to choose the scaling you want. The Ct-S setting can be 1, 10, or 100.

**NOTE:** If you are prompted to enter a password, refer to Section 7.2.4 for instructions on doing so.

2. When the new setting is entered, press the **Menu** button twice.

3. The Store ALL YES screen appears. Press **Enter** to save the new CT setting.

#### Example CT Settings:

200/5 Amps: Set the Ct-n value for 200 and the Ct-S value for 1.

800/5 Amps: Set the Ct-n value for 800 and the Ct-S value for 1.

2,000/5 Amps: Set the Ct-n value for 2000 and the Ct-S value for 1.

10,000/5 Amps: Set the Ct-n value for 1000 and the Ct-S value for 10.

#### NOTES:

- The value for Amps is a product of the Ct-n value and the Ct-S value.
- Ct-n and Ct-S are dictated by primary current; Ct-d is secondary current.

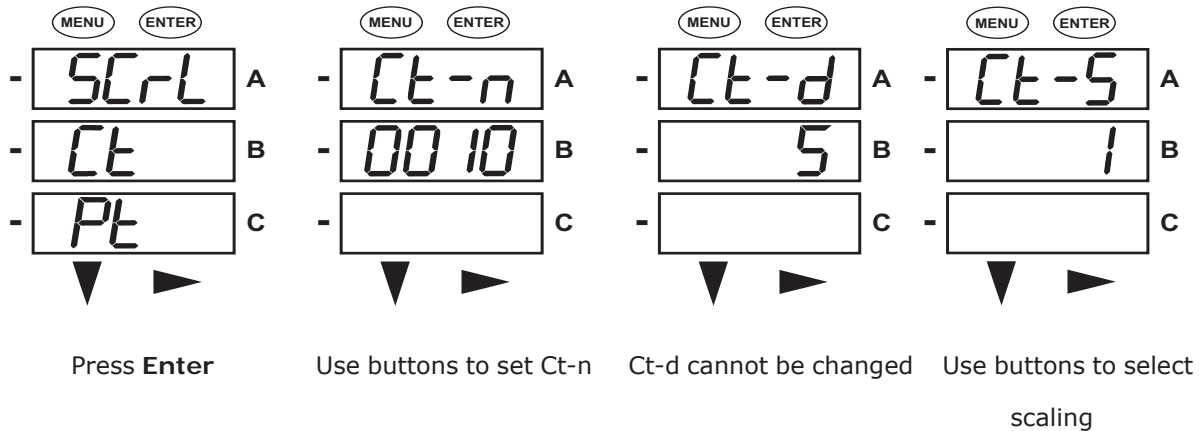

#### 7.2.5.3: Configuring PT Setting

The PT Setting has three parts: Pt-n (numerator), Pt-d (denominator), and Pt-S (scaling).

1. Press the **Enter** button when Pt is in the A window. The PT-n screen appears. You can either:

- Change the value for the PT numerator.
- Access one of the other PT screens by pressing the **Enter** button: press **Enter** once to access the Pt-d screen, twice to access the Pt-S screen.

a. To change the value for the PT numerator or denominator:

From the Pt-n or Pt-d screen:

- Use the **Down** button to select the number value for a digit.
- Use the **Right** button to move to the next digit.

b. To change the value for the PT scaling:

From the Pt-S screen:

Use the **Right** button or the **Down** button to choose the scaling you want. The Pt-S setting can be 1, 10, 100, or 1000.

**NOTE:** If you are prompted to enter a password, refer to Section 7.2.4 for instructions on doing so.

2. When the new setting is entered, press the **Menu** button twice.

3. The STOR ALL YES screen appears. Press **Enter** to save the new PT setting.

#### Example PT Settings:

277/277 Volts: Pt-n value is 277, Pt-d value is 277, Pt-S value is 1.

14,400/120 Volts: Pt-n value is 1440, Pt-d value is 120, Pt-S value is 10.

138,000/69 Volts: Pt-n value is 1380, Pt-d value is 69, Pt-S value is 100.

345,000/115 Volts: Pt-n value is 3450, Pt-d value is 115, Pt-S value is 100.

345,000/69 Volts: Pt-n value is 345, Pt-d value is 69, Pt-S value is 1000.

**NOTE:** Pt-n and Pt-S are dictated by primary voltage; Pt-d is secondary voltage.

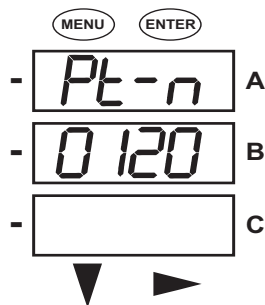

Use buttons to set Pt-n

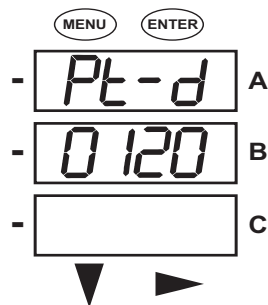

Use buttons to set Pt-d

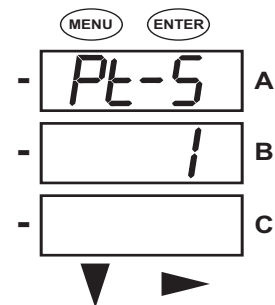

Use buttons to select scaling

### 7.2.5.4: Configuring Connection Setting

1. Press the **Enter** button when Cnct is in the A window. The Cnct screen appears.
2. Press the **Right** button or **Down** button to select a configuration. The choices are:

- 3 Element Wye (3 EL WYE)
- 2.5 Element Wye (2.5EL WYE)
- 2 CT Delta (2 Ct dEL)

**NOTE:** If you are prompted to enter a password, refer to Section 7.2.4 for instructions on doing so.

3. When you have made your selection, press the **Menu** button twice.
4. The STOR ALL YES screen appears. Press **Enter** to save the setting.

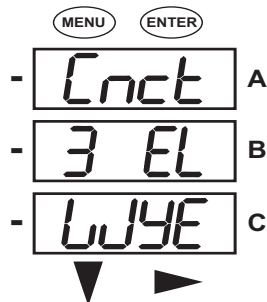

Use buttons to select configuration

### 7.2.5.5: Configuring Communication Port Setting

Port configuration consists of: Address (a three digit number), Baud Rate (9600; 19200; 38400; or 57600), and Protocol (DNP 3.0; Modbus RTU; or Modbus ASCII).

1. Press the **Enter** button when PORT is in the A window. The Adr (address) screen appears. You can either:
  - Enter the address.
  - Access one of the other Port screens by pressing the **Enter** button: press **Enter** once to access the bAUd screen (Baud Rate), twice to access the Prot screen (Protocol).

- a. To enter the Address

From the Adr screen:

- Use the **Down** button to select the number value for a digit.
- Use the **Right** button to move to the next digit.

- b. To select the Baud Rate:

From the bAUd screen:

Use the **Right** button or the **Down** button to select the setting you want.

- c. To select the Protocol:

From the Prot screen:

Press the **Right** button or the **Down** button to select the setting you want.

**NOTE:** If you are prompted to enter a password, refer to Section 7.2.4 for instructions on doing so.

2. When you have finished making your selections, press the **Menu** button twice.

3. The STOR ALL YES screen appears. Press **Enter** to save the settings.

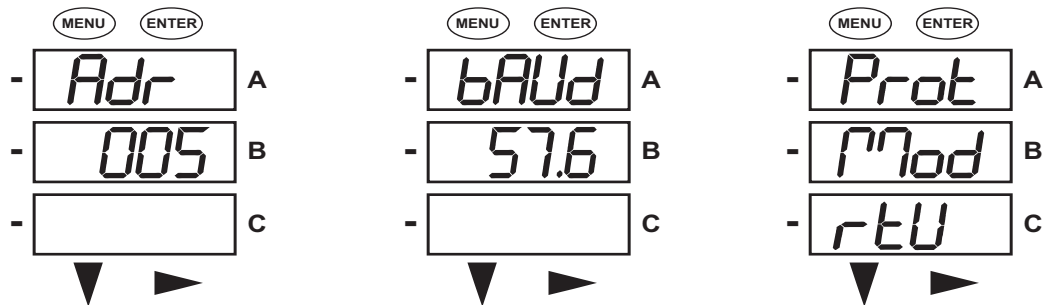

Use buttons to enter Address    Use buttons to select Baud Rate    Use buttons to select Protocol

### 7.2.6: Using Operating Mode

Operating mode is the Shark® 100S submeter's default mode, that is, the standard front panel display. After starting up, the meter automatically scrolls through the parameter screens, if scrolling is enabled. Each parameter is shown for 7 seconds, with a 1 second pause between parameters. Scrolling is suspended for 3 minutes after any button is pressed.

1. Press the **Down** button to scroll all the parameters in Operating mode. The currently "Active," i.e., displayed, parameter has the Indicator light next to it, on the right face of the meter.
2. Press the **Right** button to view additional readings for that parameter. The table below shows possible readings for Operating mode. Sheet 2 in Appendix A shows the Operating mode Navigation map.

**NOTE:** Readings or groups of readings are skipped if not applicable to the meter type or hookup, or if they are disabled in the programmable settings.

#### OPERATING MODE PARAMETER READINGS

##### POSSIBLE READINGS

VOLTS L-N	VOLTS_LN	VOLTS_L-N_MAX	VOLTS_L-N_MIN		VOLTS_L-N_THD
VOLTS L-L	VOLTS_LL	VOLTS_LL_MAX	VOLTS_LL_MIN		
AMPS	AMPS	AMPS_-NEUTRAL	AMPS_MAX	AMPS_MIN	AMPS_THD
W/VAR/PF	W_VAR_PF	W_VAR_P-F_MAX_-POS	W_VAR_P-F_MIN_POS	W_VAR_P-F_MIN_NEG	
VA/Hz	VA_FREQ	VA_FREQ_-MAX	VA_FREQ_MIN		
Wh	KWH_REC	KWH_DEL	KWH_NET	KWH_TOT	
VARh	KVARH_-POS	KVARH_-NEG	KVARH_-NET	KVARH_-TOT	
VAh	KVAH				



### 7.3: Understanding the % of Load Bar

The 10-segment LED bar graph at the bottom left of the Shark® 100S meter's front panel provides a graphic representation of Amps. The segments light according to the load, as shown in the table below.

When the Load is over 120% of Full Load, all segments flash "On" (1.5 secs) and "Off" (0.5 secs).

Segments	Load >= % Full Load
none	no load
1	1%
1-2	15%
1-3	30%
1-4	45%
1-5	60%
1-6	72%
1-7	84%
1-8	96%
1-9	108%
1-10	120%
All Blink	>120%

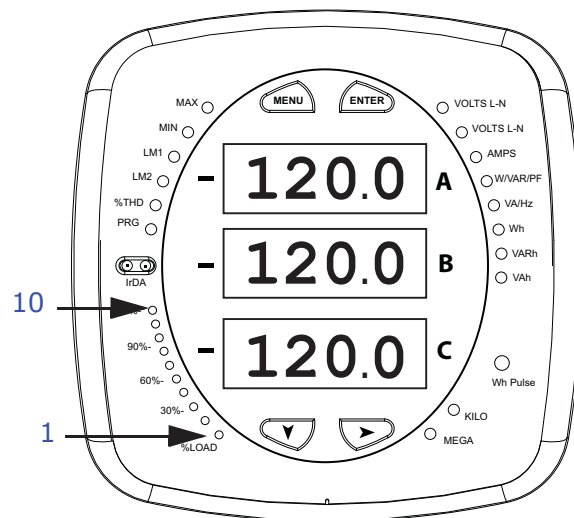

## 7.4: Performing Watt-Hour Accuracy Testing (Verification)

To be certified for revenue metering, power providers and utility companies must verify that the billing energy meter performs to the stated accuracy. To confirm the meter's performance and calibration, power providers use field test standards to ensure that the unit's energy measurements are correct. Since the Shark® 100S submeter is a traceable revenue meter, it contains a utility grade test pulse that can be used to gate an accuracy standard. This is an essential feature required of all billing grade meters.

- Refer to Figure 7.5 for an example of how this process works.
- Refer to Table 7.1 for the Wh/Pulse constants for accuracy testing.

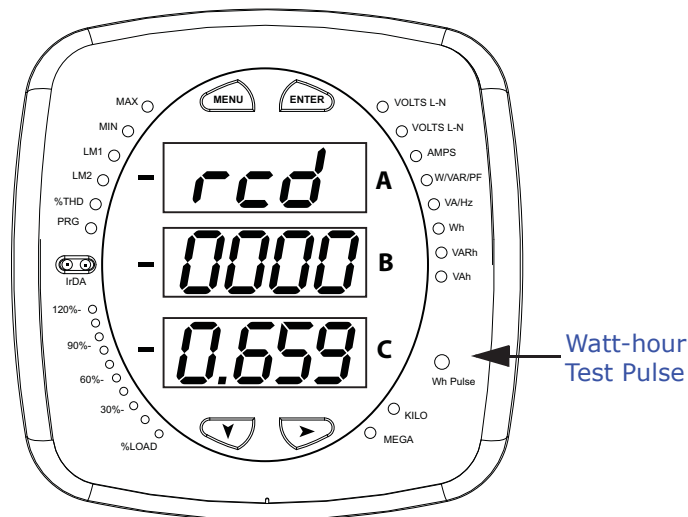

Figure 7.4: Watt-hour Test Pulse

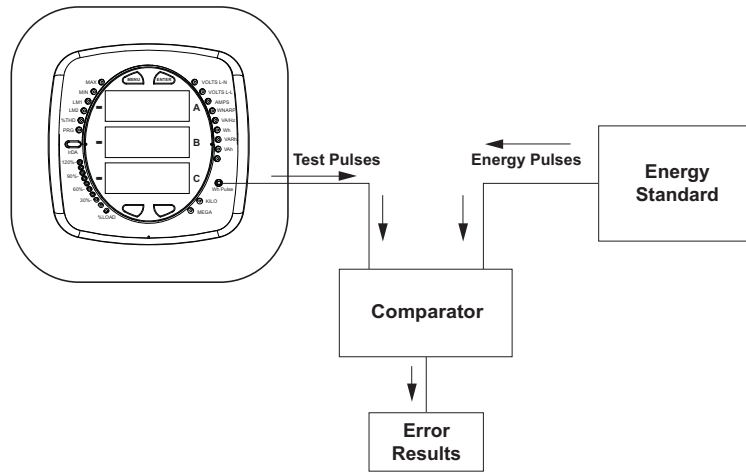

Figure 7.5: Using the Watt-hour Test Pulse

Input Voltage Level	Class 10 Models	Class 2 Models
Below 150V	0.2505759630	0.0501151926
Above 150V	1.0023038521	0.2004607704

Table 7.1: Infrared &amp; KYZ Pulse Constants for Accuracy Testing - Kh Watt-hour per pulse

**NOTES:**

- Minimum pulse width is 40 milliseconds.
- Refer to Chapter 2, Section 2.2, for Wh Pulse specifications.

## 7.5: Upgrade the Submeter Using V-Switch™ Key Technology

The Shark® 100S meter is equipped with V-Switch™ key technology. V-Switch™ key technology is a virtual firmware-based switch that allows you to enable submeter features through communication. This allows the unit to be upgraded after installation to a higher model without removing the unit from service.

### Available V-Switch™ keys

V-Switch™ key 3 (V-3): Volts, Amps, kW, kVAR, PF, kVA, Freq., kWh, kVAh, kVARh & DNP 3.0

V-Switch™ key 4 (V-4): Volts, Amps, kW, kVAR, PF, kVA, Freq., kWh, kVAh, kVARh, %THD Monitoring, Limit Exceeded Alarms & DNP.3.0

### To obtain a V-Switch™ key

V-Switch™ keys are based on the particular serial number of the ordered submeter. To obtain a higher V-Switch™ key, you need to provide EIG with the following information:

- Serial number(s) of the submeter(s) you want to upgrade.
- Desired V-Switch™ key upgrade
- Credit Card or Purchase Order Number.

### To change the V-Switch™ key:

1. Install Communicator EXT™ software on your computer.
2. Set up the Shark® 100S submeter to communicate with your computer (see Chapter 5); power up your submeter.
3. Log on to Communicator EXT™ software.
4. From the Main screen, click **Tools>Change V-Switch**. You will see the screen shown on the next page.

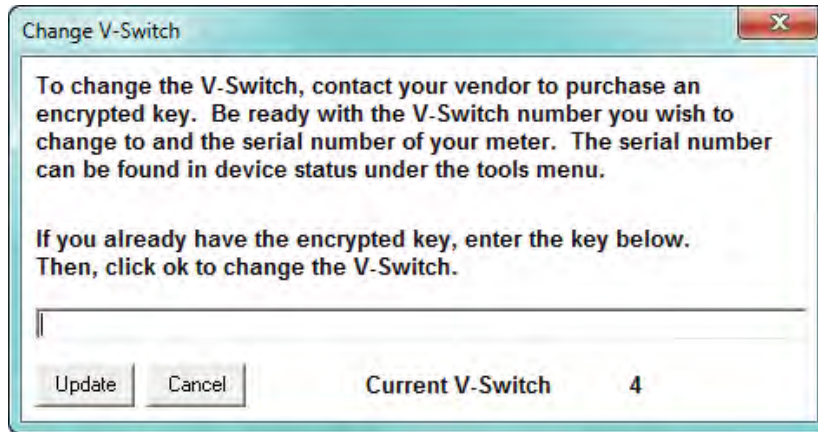

5. Enter the Upgrade code provided by EIG.
6. Click **OK**. The V-Switch™ key is changed and the submeter resets.

**NOTE:** For more details on software configuration, refer to the *Communicator EXT™ 4.0 and MeterManager EXT Software User Manual*.

# A: Shark® 100S Meter Navigation Maps

## A.1: Introduction

You can configure the Shark® 100S meter and perform related tasks using the buttons on the meter face. Chapter 7 contains a description of the buttons on the meter face and instructions for programming the meter using them. The meter can also be programmed using software (see Chapter 5 and the *Communicator EXT™ 4.0 and MeterManager EXT Software User Manual*).

## A.2: Navigation Maps (Sheets 1 to 4)

The Shark® 100S meter's Navigation maps begin on the next page. The maps show in detail how to move from one screen to another and from one display mode to another using the buttons on the face of the meter. All display modes automatically return to Operating mode after 10 minutes with no user activity.

### **Shark® 100S meter Navigation map titles**

- Main Menu Screens (Sheet 1)
- Operating mode screens (Sheet 2)
- Reset mode screens (Sheet 3)
- Configuration mode screens (Sheet 4)

Main Menu Screens (Sheet 1)

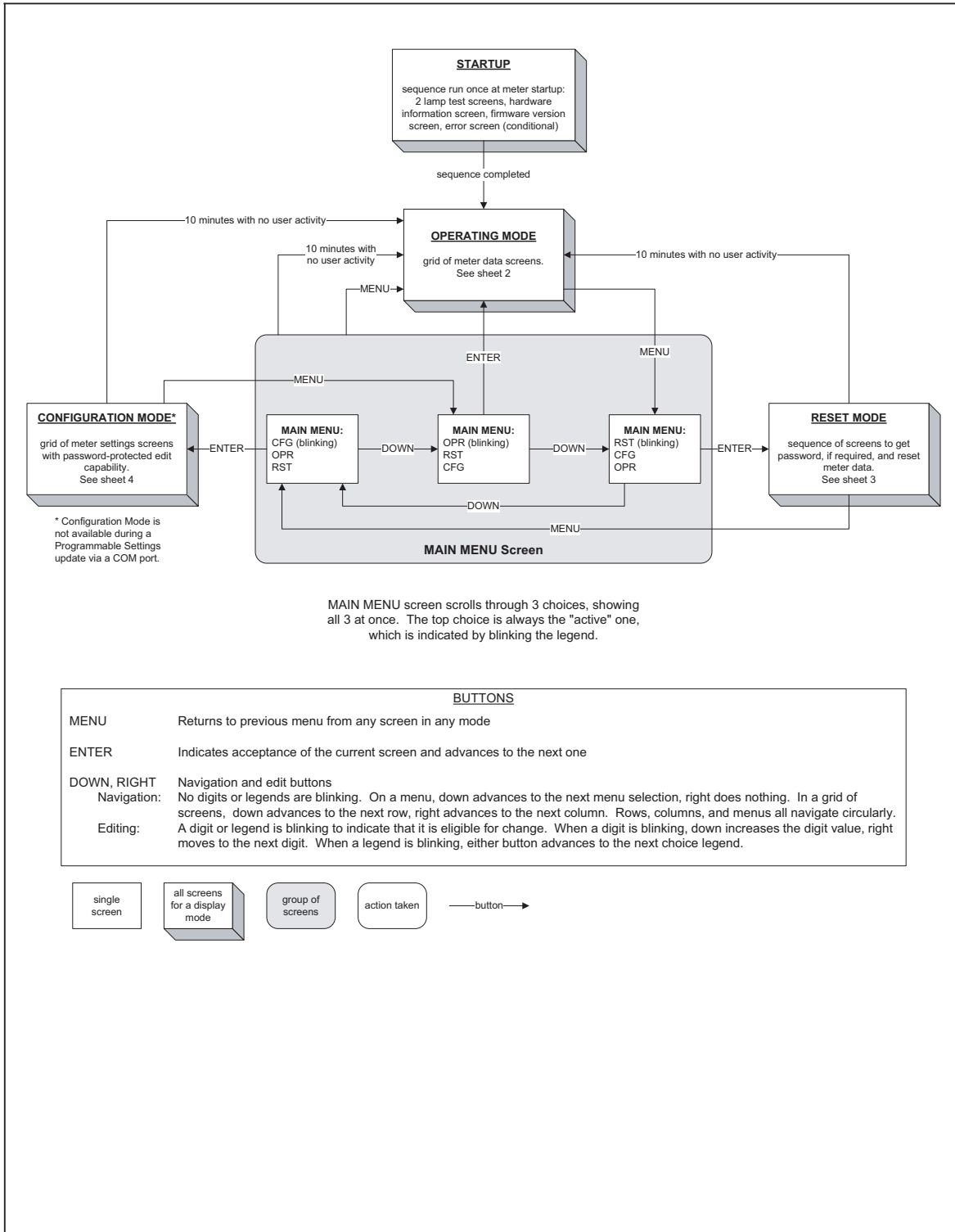

Operating Mode Screens (Sheet 2)

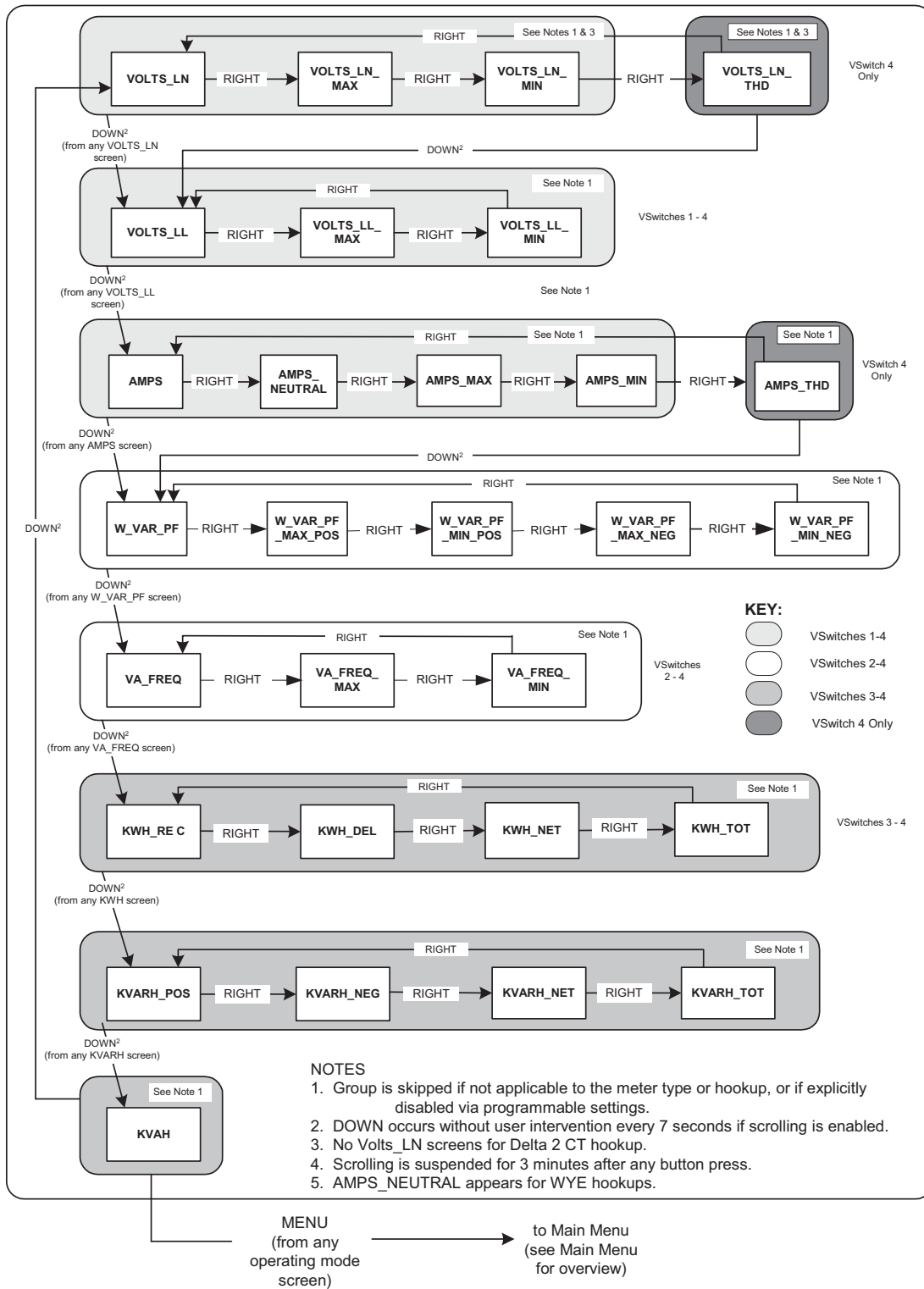



Reset Mode Screens (Sheet 3)

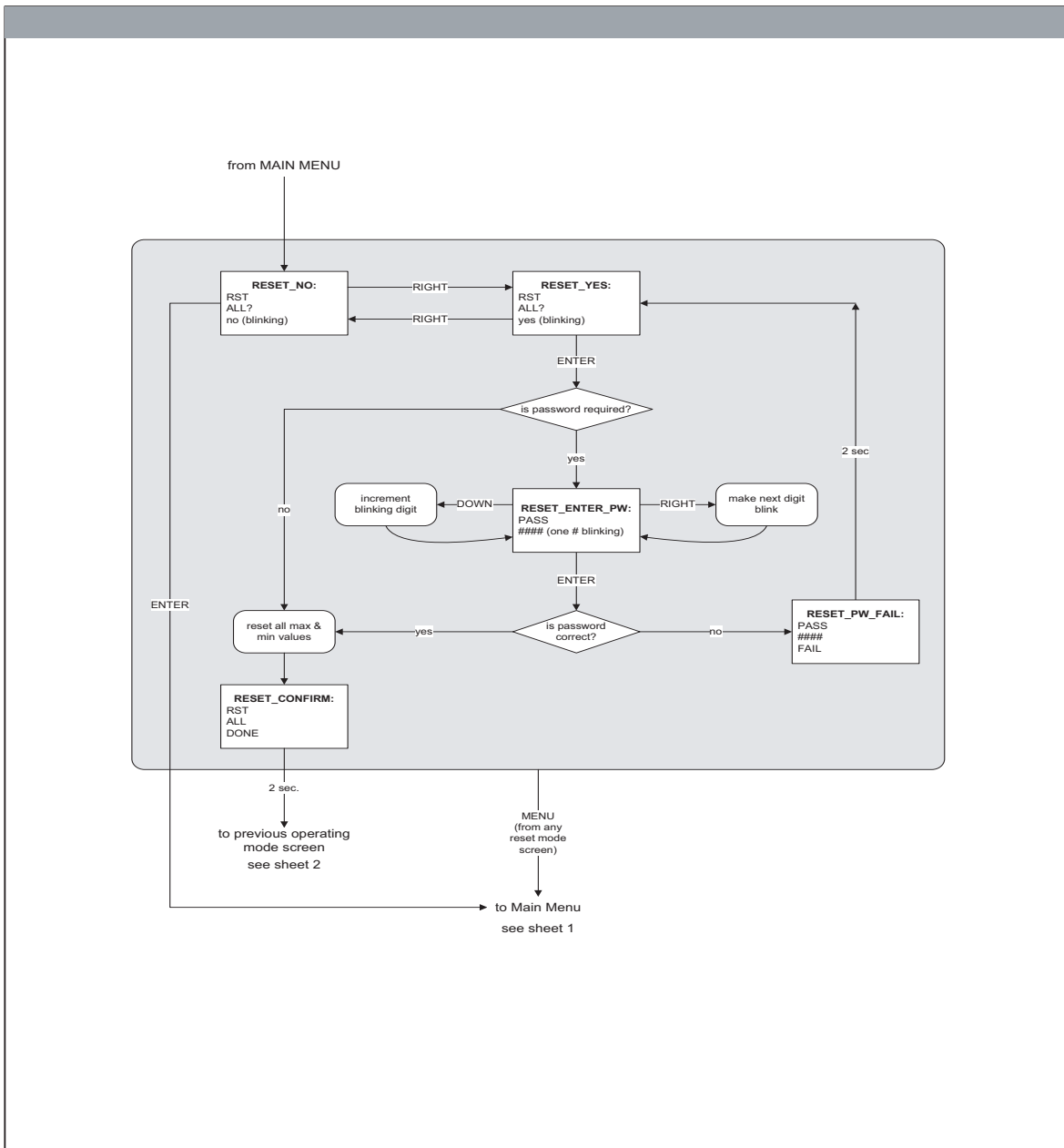

Configuration Mode Screens (Sheet 4)

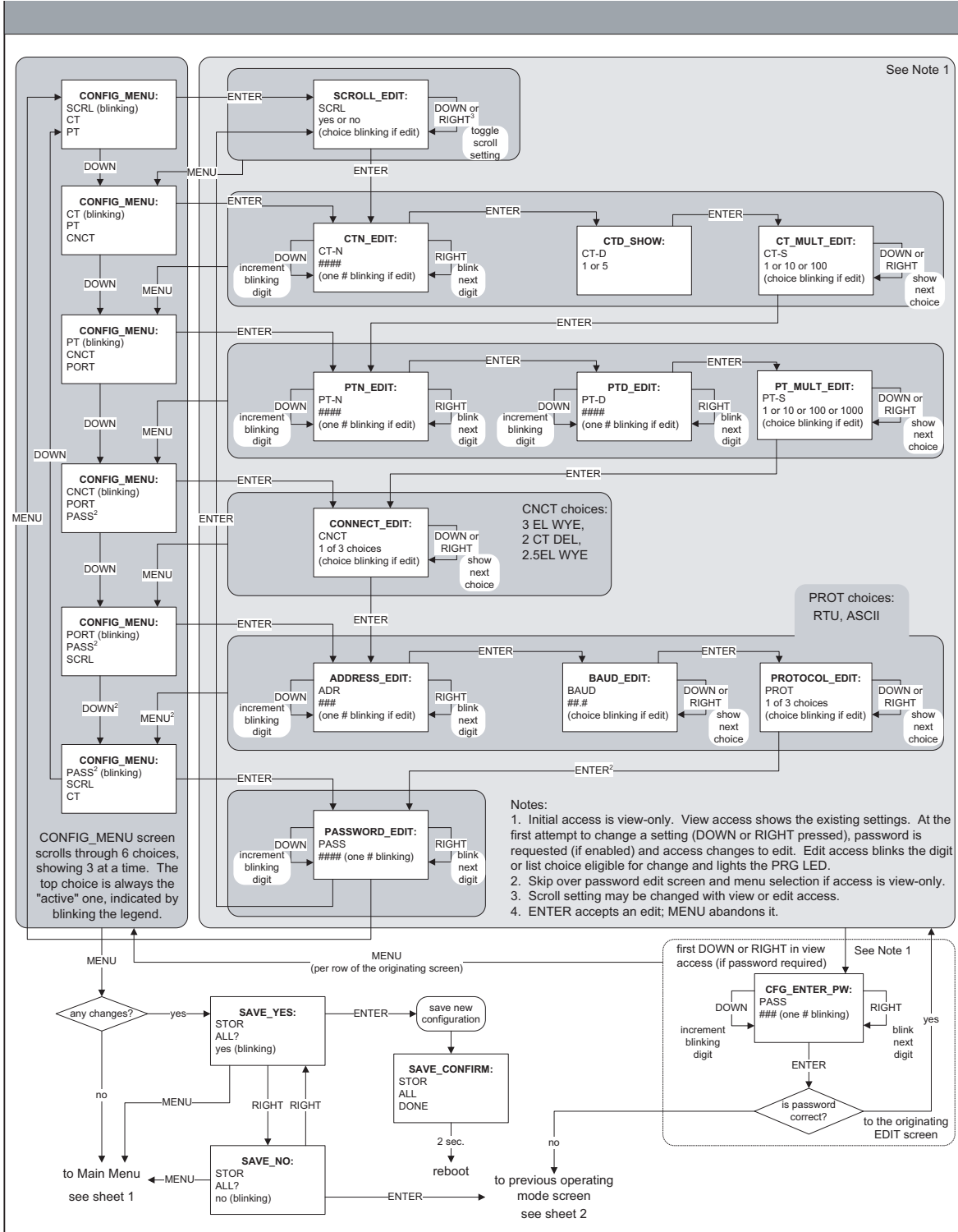

## B: Shark® 100S Meter Modbus Map

### B.1: Introduction

The Modbus Map for the Shark® 100S Meter gives details and information about the possible readings of the meter and about the programming of the meter. The Shark® 100S can be programmed using the buttons on the face plate of the meter (Chapter 7). The meter can also be programmed using software. For a programming overview, see Section 5.2. For further details see the *Communicator EXT™ 4.0 and MeterManager EXT Software User Manual*.

### B.2: Modbus Register Map Sections

The Shark® 100S Modbus Register Map includes the following sections:

Fixed Data Section, Registers 1- 47, details the Meter's Fixed Information described in Section 8.2.

Meter Data Section, Registers 1000 - 5003, details the Meter's Readings, including Primary Readings, Energy Block, Demand Block, Maximum and Minimum Blocks, THD Block, Phase Angle Block and Status Block. Operating Mode readings are described in Section 7.2.6.

Commands Section, Registers 20000 - 26011, details the Meter's Resets Block, Programming Block, Other Commands Block and Encryption Block.

Programmable Settings Section, Registers 30000 - 30067, details the Meter's Basic Setups.

Secondary Readings Section, Registers 40001 - 40100, details the Meter's Secondary Readings Setups.

### B.3: Data Formats

ASCII:	ASCII characters packed 2 per register in high, low order and without any termination characters.
SINT16/UINT16:	16-bit signed/unsigned integer.
SINT32/UINT32:	32-bit signed/unsigned integer spanning 2 registers. The lower-addressed register is the



The Exponent is 10001001 (binary) or 137 decimal.

The Exponent is a value in excess 127. So, the Exponent value is 10.

The Mantissa is 11000010001110110111001 binary.

With the implied leading 1, the Mantissa is (1).611DB9 (hex).

The Floating Point Representation is therefore -1.75871956 times 2 to the 10.

Decimal equivalent: -1800.929

**NOTES:**

- Exponent = the whole number before the decimal point.
- Mantissa = the positive fraction after the decimal point.

## **B.5: Modbus Register Map**

The Shark® 100S meter's Modbus register map begins on the following page.

Modbus Address		Description <sup>1</sup>	Format	Range <sup>6</sup>	Units or Resolution	Comments	# Reg
Hex	Decimal						
<b>Fixed Data Section</b>							
							read-only
<b>Identification Block</b>							
0000 - 0007	1 - 8	Meter Name	ASCII	16 char	none		8
0008 - 000F	9 - 16	Meter Serial Number	ASCII	16 char	none		8
0010 - 0010	17 - 17	Meter Type	UINT16	bit-mapped	-----t -----vvv	t = transducer model (1=yes, 0=no), vvv = V-switch(1 to 4)	1
0011 - 0012	18 - 19	Firmware Version	ASCII	4 char	none		2
0013 - 0013	20 - 20	Map Version	UINT16	0 to 65535	none		1
0014 - 0014	21 - 21	Meter Configuration	UINT16	bit-mapped	----- --fffff	fffff = calibration frequency (50 or 60)	1
0015 - 0015	22 - 22	ASIC Version	UINT16	0-65535	none		1
0016 - 0026	23 - 39	Reserved					17
0027 - 002E	40 - 47	Reserved					8
Block Size:							47
<b>Meter Data Section<sup>2</sup></b>							
							read-only
<b>Primary Readings Block, 6 cycles (IEEE Floating Point)</b>							
0383 - 0384	900 - 901	Watts, 3-Ph total	FLOAT	-9999 M to +9999 M	watts		2
0385 - 0386	902 - 903	VARs, 3-Ph total	FLOAT	-9999 M to +9999 M	VARs		2
0387 - 0388	904 - 905	VA, 3-Ph total	FLOAT	-9999 M to +9999 M	VA		2
Block Size:							6
<b>Primary Readings Block, 60 cycles (IEEE Floating Point)</b>							
							read-only
03E7 - 03E8	1000 - 1001	Volts A-N	FLOAT	0 to 9999 M	volts		2
03E9 - 03EA	1002 - 1003	Volts B-N	FLOAT	0 to 9999 M	volts		2
03EB - 03EC	1004 - 1005	Volts C-N	FLOAT	0 to 9999 M	volts		2
03ED - 03EE	1006 - 1007	Volts A-B	FLOAT	0 to 9999 M	volts		2
03EF - 03F0	1008 - 1009	Volts B-C	FLOAT	0 to 9999 M	volts		2
03F1 - 03F2	1010 - 1011	Volts C-A	FLOAT	0 to 9999 M	volts		2
03F3 - 03F4	1012 - 1013	Amps A	FLOAT	0 to 9999 M	amps		2
03F5 - 03F6	1014 - 1015	Amps B	FLOAT	0 to 9999 M	amps		2
03F7 - 03F8	1016 - 1017	Amps C	FLOAT	0 to 9999 M	amps		2
03F9 - 03FA	1018 - 1019	Watts, 3-Ph total	FLOAT	-9999 M to +9999 M	watts		2
03FB - 03FC	1020 - 1021	VARs, 3-Ph total	FLOAT	-9999 M to +9999 M	VARs		2
03FD - 03FE	1022 - 1023	VA, 3-Ph total	FLOAT	-9999 M to +9999 M	VA		2
03FF - 0400	1024 - 1025	Power Factor, 3-Ph total	FLOAT	-1.00 to +1.00	none		2
0401 - 0402	1026 - 1027	Frequency	FLOAT	0 to 65.00	Hz		2
0403 - 0404	1028 - 1029	Neutral Current	FLOAT	0 to 9999 M	amps		2
Block Size:							30

Modbus Address		Description <sup>1</sup>	Format	Range <sup>6</sup>	Units or Resolution	Comments	# Reg
Hex	Decimal						
<b>Primary Energy Block</b> <span style="float:right">read-only</span>							
044B - 044C	1100 - 1101	W-hours, Received	SINT32	0 to 99999999 or 0 to -99999999	Wh per energy format	* Wh received & delivered always have opposite signs	2
044D - 044E	1102 - 1103	W-hours, Delivered	SINT32	0 to 99999999 or 0 to -99999999	Wh per energy format	* Wh received is positive for "view as load", delivered is positive for "view as generator"	2
044F - 0450	1104 - 1105	W-hours, Net	SINT32	-99999999 to 99999999	Wh per energy format		2
0451 - 0452	1106 - 1107	W-hours, Total	SINT32	0 to 99999999	Wh per energy format	* 5 to 8 digits	2
0453 - 0454	1108 - 1109	VAR-hours, Positive	SINT32	0 to 99999999	VARh per energy format		2
0455 - 0456	1110 - 1111	VAR-hours, Negative	SINT32	0 to -99999999	VARh per energy format	* decimal point implied, per energy format	2
0457 - 0458	1112 - 1113	VAR-hours, Net	SINT32	-99999999 to 99999999	VARh per energy format	* resolution of digit before decimal point = units, kilo, or mega, per energy format	2
0459 - 045A	1114 - 1115	VAR-hours, Total	SINT32	0 to 99999999	VARh per energy format		2
045B - 045C	1116 - 1117	VA-hours, Total	SINT32	0 to 99999999	VAh per energy format	* see note 10	2
Block Size:							18
<b>Primary Demand Block (IEEE Floating Point)</b> <span style="float:right">read-only</span>							
07CF - 07D0	2000 - 2001	Amps A, Average	FLOAT	0 to 9999 M	amps		2
07D1 - 07D2	2002 - 2003	Amps B, Average	FLOAT	0 to 9999 M	amps		2
07D3 - 07D4	2004 - 2005	Amps C, Average	FLOAT	0 to 9999 M	amps		2
07D5 - 07D6	2006 - 2007	Positive Watts, 3-Ph, Average	FLOAT	-9999 M to +9999 M	watts		2
07D7 - 07D8	2008 - 2009	Positive VARs, 3-Ph, Average	FLOAT	-9999 M to +9999 M	VARs		2
07D9 - 07DA	2010 - 2011	Negative Watts, 3-Ph, Average	FLOAT	-9999 M to +9999 M	watts		2
07DB - 07DC	2012 - 2013	Negative VARs, 3-Ph, Average	FLOAT	-9999 M to +9999 M	VARs		2
07DD - 07DE	2014 - 2015	VAs, 3-Ph, Average	FLOAT	-9999 M to +9999 M	VAs		2
07DF - 07E0	2016 - 2017	Positive PF, 3-Ph, Average	FLOAT	-1.00 to +1.00	none		2
07E1 - 07E2	2018 - 2019	Negative PF, 3-PF, Average	FLOAT	-1.00 to +1.00	none		2
Block Size:							20
<b>Primary Minimum Block (IEEE Floating Point)</b> <span style="float:right">read-only</span>							
0BB7 - 0BB8	3000 - 3001	Volts A-N, Minimum	FLOAT	0 to 9999 M	volts		2
0BB9 - 0BBA	3002 - 3003	Volts B-N, Minimum	FLOAT	0 to 9999 M	volts		2
0BBB - 0BBC	3004 - 3005	Volts C-N, Minimum	FLOAT	0 to 9999 M	volts		2
0BBD - 0BBE	3006 - 3007	Volts A-B, Minimum	FLOAT	0 to 9999 M	volts		2
0BBF - 0BC0	3008 - 3009	Volts B-C, Minimum	FLOAT	0 to 9999 M	volts		2
0BC1 - 0BC2	3010 - 3011	Volts C-A, Minimum	FLOAT	0 to 9999 M	volts		2
0BC3 - 0BC4	3012 - 3013	Amps A, Minimum Avg Demand	FLOAT	0 to 9999 M	amps		2
0BC5 - 0BC6	3014 - 3015	Amps B, Minimum Avg Demand	FLOAT	0 to 9999 M	amps		2
0BC7 - 0BC8	3016 - 3017	Amps C, Minimum Avg Demand	FLOAT	0 to 9999 M	amps		2
0BC9 - 0BCA	3018 - 3019	Positive Watts, 3-Ph, Minimum Avg Demand	FLOAT	0 to +9999 M	watts		2
0BCB - 0BCC	3020 - 3021	Positive VARs, 3-Ph, Minimum Avg Demand	FLOAT	0 to +9999 M	VARs		2
0BCD - 0BCE	3022 - 3023	Negative Watts, 3-Ph, Minimum Avg Demand	FLOAT	0 to +9999 M	watts		2
0BCF - 0BD0	3024 - 3025	Negative VARs, 3-Ph, Minimum Avg Demand	FLOAT	0 to +9999 M	VARs		2
0BD1 - 0BD2	3026 - 3027	VAs, 3-Ph, Minimum Avg Demand	FLOAT	-9999 M to +9999 M	VAs		2
0BD3 - 0BD4	3028 - 3029	Positive Power Factor, 3-Ph, Minimum Avg Demand	FLOAT	-1.00 to +1.00	none		2

Modbus Address		Description <sup>1</sup>	Format	Range <sup>6</sup>	Units or Resolution	Comments	# Reg
Hex	Decimal						
0BD5 - 0BD6	3030 - 3031	Negative Power Factor, 3-Ph, Minimum Avg Demand	FLOAT	-1.00 to +1.00	none		2
0BD7 - 0BD8	3032 - 3033	Frequency, Minimum	FLOAT	0 to 65.00	Hz		2
						Block Size:	34
Primary Maximum Block (IEEE Floating Point)							read-only
0C1B - 0C1C	3100 - 3101	Volts A-N, Maximum	FLOAT	0 to 9999 M	volts		2
0C1D - 0C1E	3102 - 3103	Volts B-N, Maximum	FLOAT	0 to 9999 M	volts		2
0C1F - 0C20	3104 - 3105	Volts C-N, Maximum	FLOAT	0 to 9999 M	volts		2
0C21 - 0C22	3106 - 3107	Volts A-B, Maximum	FLOAT	0 to 9999 M	volts		2
0C23 - 0C24	3108 - 3109	Volts B-C, Maximum	FLOAT	0 to 9999 M	volts		2
0C25 - 0C26	3110 - 3111	Volts C-A, Maximum	FLOAT	0 to 9999 M	volts		2
0C27 - 0C28	3112 - 3113	Amps A, Maximum Avg Demand	FLOAT	0 to 9999 M	amps		2
0C29 - 0C2A	3114 - 3115	Amps B, Maximum Avg Demand	FLOAT	0 to 9999 M	amps		2
0C2B - 0C2C	3116 - 3117	Amps C, Maximum Avg Demand	FLOAT	0 to 9999 M	amps		2
0C2D - 0C2E	3118 - 3119	Positive Watts, 3-Ph, Maximum Avg Demand	FLOAT	0 to +9999 M	watts		2
0C2F - 0C30	3120 - 3121	Positive VARs, 3-Ph, Maximum Avg Demand	FLOAT	0 to +9999 M	VARs		2
0C31 - 0C32	3122 - 3123	Negative Watts, 3-Ph, Maximum Avg Demand	FLOAT	0 to +9999 M	watts		2
0C33 - 0C34	3124 - 3125	Negative VARs, 3-Ph, Maximum Avg Demand	FLOAT	0 to +9999 M	VARs		2
0C35 - 0C36	3126 - 3127	VA's, 3-Ph, Maximum Avg Demand	FLOAT	-9999 M to +9999 M	VA's		2
0C37 - 0C38	3128 - 3129	Positive Power Factor, 3-Ph, Maximum Avg Demand	FLOAT	-1.00 to +1.00	none		2
0C39 - 0C3A	3130 - 3131	Negative Power Factor, 3-Ph, Maximum Avg Demand	FLOAT	-1.00 to +1.00	none		2
0C3B - 0C3C	3132 - 3133	Frequency, Maximum	FLOAT	0 to 65.00	Hz		2
						Block Size:	34
THD Block <sup>2-13</sup>							read-only
0F9F - 0F9F	4000 - 4000	Volts A-N, %THD	UINT16	0 to 9999, or 65535	0.1%		1
0FA0 - 0FA0	4001 - 4001	Volts B-N, %THD	UINT16	0 to 9999, or 65535	0.1%		1
0FA1 - 0FA1	4002 - 4002	Volts C-N, %THD	UINT16	0 to 9999, or 65535	0.1%		1
0FA2 - 0FA2	4003 - 4003	Amps A, %THD	UINT16	0 to 9999, or 65535	0.1%		1
0FA3 - 0FA3	4004 - 4004	Amps B, %THD	UINT16	0 to 9999, or 65535	0.1%		1
0FA4 - 0FA4	4005 - 4005	Amps C, %THD	UINT16	0 to 9999, or 65535	0.1%		1
0FA5 - 0FA5	4006 - 4006	Phase A Current 0th harmonic magnitude	UINT16	0 to 65535	none		1
0FA6 - 0FA6	4007 - 4007	Phase A Current 1st harmonic magnitude	UINT16	0 to 65535	none		1
0FA7 - 0FA7	4008 - 4008	Phase A Current 2nd harmonic magnitude	UINT16	0 to 65535	none		1
0FA8 - 0FA8	4009 - 4009	Phase A Current 3rd harmonic magnitude	UINT16	0 to 65535	none		1
0FA9 - 0FA9	4010 - 4010	Phase A Current 4th harmonic magnitude	UINT16	0 to 65535	none		1
0FAA - 0FAA	4011 - 4011	Phase A Current 5th harmonic magnitude	UINT16	0 to 65535	none		1
0FAB - 0FAB	4012 - 4012	Phase A Current 6th harmonic magnitude	UINT16	0 to 65535	none		1
0FAC - 0FAC	4013 - 4013	Phase A Current 7th harmonic magnitude	UINT16	0 to 65535	none		1
0FAD - 0FAD	4014 - 4014	Phase A Voltage 0th harmonic magnitude	UINT16	0 to 65535	none		1
0FAE - 0FAE	4015 - 4015	Phase A Voltage 1st harmonic magnitude	UINT16	0 to 65535	none		1
0FAF - 0FAF	4016 - 4016	Phase A Voltage 2nd harmonic magnitude	UINT16	0 to 65535	none		1
0FB0 - 0FB0	4017 - 4017	Phase A Voltage 3rd harmonic magnitude	UINT16	0 to 65535	none		1
0FB1 - 0FB8	4018 - 4025	Phase B Current harmonic magnitudes		same as Phase A Current 0th to 7th harmonic magnitudes			8
0FB9 - 0FBC	4026 - 4029	Phase B Voltage harmonic magnitudes		same as Phase A Voltage 0th to 3rd harmonic magnitude:			4
0FBD - 0FC4	4030 - 4037	Phase C Current harmonic magnitudes		same as Phase A Current 0th to 7th harmonic magnitudes:			8
0FC5 - 0FC8	4038 - 4041	Phase C Voltage harmonic magnitudes		same as Phase A Voltage 0th to 3rd harmonic magnitude:			4
						Block Size:	42



Modbus Address		Description <sup>1</sup>	Format	Range <sup>6</sup>	Units or Resolution	Comments	# Reg	
Hex	Decimal							
Phase Angle Block <sup>14</sup>								
1003 - 1003	4100 - 4100	Phase A Current	SINT16	-1800 to +1800	0.1 degree	read-only	1	
1004 - 1004	4101 - 4101	Phase B Current	SINT16	-1800 to +1800	0.1 degree		1	
1005 - 1005	4102 - 4102	Phase C Current	SINT16	-1800 to +1800	0.1 degree		1	
1006 - 1006	4103 - 4103	Angle, Volts A-B	SINT16	-1800 to +1800	0.1 degree		1	
1007 - 1007	4104 - 4104	Angle, Volts B-C	SINT16	-1800 to +1800	0.1 degree		1	
1008 - 1008	4105 - 4105	Angle, Volts C-A	SINT16	-1800 to +1800	0.1 degree		1	
							Block Size:	6
Status Block								
1387 - 1387	5000 - 5000	Meter Status	UINT16	bit-mapped	--exnpch ssssssss	exnpch = EEPROM block OK flags (e=energy, x=max, n=min, p=programmable settings, c=calibration, h=header), ssssssss = state (1=Run, 2=Limp, 10=Prog Set Update via buttons, 11=Prog Set Update via IrDA, 12=Prog Set Update via COM2)	1	
1388 - 1388	5001 - 5001	Limits Status <sup>7</sup>	UINT16	bit-mapped	87654321 87654321	high byte is setpt 1, 0=in, 1=out low byte is setpt 2, 0=in, 1=out	1	
1389 - 138A	5002 - 5003	Time Since Reset	UINT32	0 to 4294967294	4 msec	wraps around after max coun!	2	
							Block Size:	4
<b>Commands Section<sup>4</sup></b>								
Resets Block <sup>3</sup>								
4E1F - 4E1F	20000 - 20000	Reset Max/Min Blocks	UINT16	password <sup>5</sup>		write-only	1	
4E20 - 4E20	20001 - 20001	Reset Energy Accumulators	UINT16	password <sup>5</sup>			1	
							Block Size:	2
Meter Programming Block								
55EF - 55EF	22000 - 22000	Initiate Programmable Settings Update	UINT16	password <sup>5</sup>		meter enters PS update mode	1	
55F0 - 55F0	22001 - 22001	Terminate Programmable Settings Update <sup>3</sup>	UINT16	any value			1	
55F1 - 55F1	22002 - 22002	Calculate Programmable Settings Checksum <sup>3</sup>	UINT16			meter leaves PS update mode via reset meter calculates checksum on RAM copy of PS block	1	
55F2 - 55F2	22003 - 22003	Programmable Settings Checksum <sup>3</sup>	UINT16			read/write checksum register; PS block saved in EEPROM on write <sup>8</sup>	1	
55F3 - 55F3	22004 - 22004	Write New Password <sup>3</sup>	UINT16	0000 to 9999		write-only register; always reads zero	1	
59D7 - 59D7	23000 - 23000	Initiate Meter Firmware Reprogramming	UINT16	password <sup>5</sup>			1	
							Block Size:	6

Modbus Address		Description <sup>1</sup>	Format	Range <sup>6</sup>	Units or Resolution	Comments	# Reg
Hex	Decimal						
<b>Other Commands Block</b> <span style="float: right;">read/write</span>							
61A7 - 61A7	25000 - 25000	Force Meter Restart	UINT16	password <sup>5</sup>		causes a watchdog reset, always reads 0	1
						Block Size:	1
<b>Encryption Block</b> <span style="float: right;">read/write</span>							
658F - 659A	26000 - 26011	Perform a Secure Operation	UINT16			encrypted command to read password or change meter type	12
						Block Size:	12
<b>Programmable Settings Section</b>							
<b>Basic Setups Block</b> <span style="float: right;">write only in PS update mode</span>							
752F - 752F	30000 - 30000	CT multiplier & denominator	UINT16	bit-mapped	ddddddd rrrrrrrrrrr	high byte is denominator (1 or 5, read-only), low byte is multiplier (1, 10, or 100)	1
7530 - 7530	30001 - 30001	CT numerator	UINT16	1 to 9999	none		1
7531 - 7531	30002 - 30002	PT numerator	UINT16	1 to 9999	none		1
7532 - 7532	30003 - 30003	PT denominator	UINT16	1 to 9999	none		1
7533 - 7533	30004 - 30004	PT multiplier & hookup	UINT16	bit-mapped	rrrrrrrrrr MMMMhhhh	MMMMmmmmmm is PT multiplier (1, 10, 100, 1000), hhhh is hookup enumeration (0 = 3 element wye[9S], 1 = delta 2 CTs[5S], 3 = 2.5 element wye[6S])	1
7534 - 7534	30005 - 30005	Averaging Method	UINT16	bit-mapped	--iiiiii b----sss	iiiiii = interval (5,15,30,60) b = 0-block or 1-rolling sss = # subintervals (1,2,3,4)	1
7535 - 7535	30006 - 30006	Power & Energy Format	UINT16	bit-mapped	pppp--nn -eee-ddd	pppp = power scale (0-unit, 3-kilo, 6-mega, 8-auto) nn = number of energy digits (5-8 --> 0-3) eee = energy scale (0-unit, 3-kilo, 6-mega) ddd = energy digits after decimal point (0-6) See note 10.	1
7536 - 7536	30007 - 30007	Operating Mode Screen Enables	UINT16	bit-mapped	00000000 eeeeeeee	eeeeeeee = op mode screen rows on(1) or off(0), rows top to bottom are bits low order to high order	1
7537 - 753D	30008 - 30014	Reserved					7

Modbus Address		Description <sup>1</sup>	Format	Range <sup>6</sup>	Units or Resolution	Comments	# Reg
Hex	Decimal						
753E - 753E	30015 - 30015	User Settings Flags	UINT16	bit-mapped	---	g = enable alternate full scale bargraph current (1=on, 0=off) nn = number of phases for voltage & current screens (3=ABC, 2=AB, 1=A, 0=ABC) s = scroll (1=on, 0=off) r = password for reset in use (1=on, 0=off) p = password for configuration in use (1=on, 0=off) w = pwr dir (0-view as load, 1-view as generator) f = flip power factor sign (1=yes, 0=no)	1
753F - 753F	30016 - 30016	Full Scale Current (for load % bargraph)	UINT16	0 to 9999	none	If non-zero and user settings bit g is set, this value replaces CT numerator in the full scale current calculation.	1
7540 - 7547	30017 - 30024	Meter Designation	ASCII	16 char	none		8
7548 - 7548	30025 - 30025	COM1 setup	UINT16	bit-mapped	----dddd -0100110	dddd = reply delay (* 50 msec) ppp = protocol (1-Modbus RTU, 2-Modbus ASCII, 3-DNP)	1
7549 - 7549	30026 - 30026	COM2 setup	UINT16	bit-mapped	----dddd -ppp-bbb	bbb = baud rate (1-9600, 2-19200, 4-38400, 6-57600)	1
754A - 754A	30027 - 30027	COM2 address	UINT16	1 to 247	none		1
754B - 754B	30028 - 30028	Limit #1 Identifier	UINT16	0 to 65535		use Modbus address as the identifier (see notes 7, 11, 12)	1
754C - 754C	30029 - 30029	Limit #1 Out High Setpoint	SINT16	-200.0 to +200.0	0.1% of full scale	Setpoint for the "above" limit (LM1), see notes 11-12.	1
754D - 754D	30030 - 30030	Limit #1 In High Threshold	SINT16	-200.0 to +200.0	0.1% of full scale	Threshold at which "above" limit clears; normally less than or equal to the "above" setpoint; see notes 11-12.	1
754E - 754E	30031 - 30031	Limit #1 Out Low Setpoint	SINT16	-200.0 to +200.0	0.1% of full scale	Setpoint for the "below" limit (LM2), see notes 11-12.	1
754F - 754F	30032 - 30032	Limit #1 In Low Threshold	SINT16	-200.0 to +200.0	0.1% of full scale	Threshold at which "below" limit clears; normally greater than or equal to the "below" setpoint; see notes 11-12.	1
7550 - 7554	30033 - 30037	Limit #2	SINT16	same as Limit #1	same as Limit #1	same as Limit #1	5
7555 - 7559	30038 - 30042	Limit #3	SINT16				5
755A - 755E	30043 - 30047	Limit #4	SINT16				5
755F - 7563	30048 - 30052	Limit #5	SINT16				5
7564 - 7568	30053 - 30057	Limit #6	SINT16				5
7569 - 756D	30058 - 30062	Limit #7	SINT16				5
756E - 7572	30063 - 30067	Limit #8	SINT16				5
Block Size:							68

Modbus Address		Description <sup>1</sup>	Format	Range <sup>6</sup>	Units or Resolution	Comments	# Reg
Hex	Decimal						
<b>12-Bit Readings Section</b>							
<b>12-Bit Block</b>							
9C40 - 9C40	40001 - 40001	System Sanity Indicator	UINT16	0 or 1	none	0 indicates proper meter operation	1
9C41 - 9C41	40002 - 40002	Volts A-N	UINT16	2047 to 4095	volts	2047= 0, 4095= +150	1
9C42 - 9C42	40003 - 40003	Volts B-N	UINT16	2047 to 4095	volts		1
9C43 - 9C43	40004 - 40004	Volts C-N	UINT16	2047 to 4095	volts	volts = 150 * (register - 2047) / 2047	1
9C44 - 9C44	40005 - 40005	Amps A	UINT16	0 to 4095	amps	0= -10, 2047= 0, 4095= +10	1
9C45 - 9C45	40006 - 40006	Amps B	UINT16	0 to 4095	amps		1
9C46 - 9C46	40007 - 40007	Amps C	UINT16	0 to 4095	amps	amps = 10 * (register - 2047) / 2047	1
9C47 - 9C47	40008 - 40008	Watts, 3-Ph total	UINT16	0 to 4095	watts	0= -3000, 2047= 0, 4095= +3000	1
9C48 - 9C48	40009 - 40009	VARs, 3-Ph total	UINT16	0 to 4095	VARs	watts, VARs, VAs =	1
9C49 - 9C49	40010 - 40010	VAs, 3-Ph total	UINT16	2047 to 4095	VAs	3000 * (register - 2047) / 2047	1
9C4A - 9C4A	40011 - 40011	Power Factor, 3-Ph total	UINT16	1047 to 3047	none	1047= -1, 2047= 0, 3047= +1 pf = (register - 2047) / 1000	1
9C4B - 9C4B	40012 - 40012	Frequency	UINT16	0 to 2730	Hz	0= 45 or less, 2047= 60, 2730= 65 or more freq = 45 + ((register / 4095) * 30)	1
9C4C - 9C4C	40013 - 40013	Volts A-B	UINT16	2047 to 4095	volts	2047= 0, 4095= +300	1
9C4D - 9C4D	40014 - 40014	Volts B-C	UINT16	2047 to 4095	volts		1
9C4E - 9C4E	40015 - 40015	Volts C-A	UINT16	2047 to 4095	volts	volts = 300 * (register - 2047) / 2047	1
9C4F - 9C4F	40016 - 40016	CT numerator	UINT16	1 to 9999	none		1
9C50 - 9C50	40017 - 40017	CT multiplier	UINT16	1, 10, 100	none	CT = numerator * multiplier / denominator	1
9C51 - 9C51	40018 - 40018	CT denominator	UINT16	1 or 5	none		1
9C52 - 9C52	40019 - 40019	PT numerator	UINT16	1 to 9999	none		1
9C53 - 9C53	40020 - 40020	PT multiplier	UINT16	1, 10, 100	none	PT = numerator * multiplier / denominator	1
9C54 - 9C54	40021 - 40021	PT denominator	UINT16	1 to 9999	none		1
9C55 - 9C56	40022 - 40023	W-hours, Positive	UINT32	0 to 99999999	Wh per energy format	* 5 to 8 digits	2
9C57 - 9C58	40024 - 40025	W-hours, Negative	UINT32	0 to 99999999	Wh per energy format	* decimal point implied, per energy format	2
9C59 - 9C5A	40026 - 40027	VAR-hours, Positive	UINT32	0 to 99999999	VARh per energy format		2
9C5B - 9C5C	40028 - 40029	VAR-hours, Negative	UINT32	0 to 99999999	VARh per energy format	* resolution of digit before decimal point = units, kilo, or mega, per energy format	2
9C5D - 9C5E	40030 - 40031	VA-hours	UINT32	0 to 99999999	VAh per energy format	* see note 10	2
9C5F - 9C5F	40032 - 40032	Neutral Current	UINT16	0 to 4095	amps	see Amps A/B/C above	1
9C60 - 9CA2	40033 - 40099	Reserved	N/A	N/A	none		67
9CA3 - 9CA3	40100 - 40100	Reset Energy Accumulators	UINT16	password <sup>5</sup>		write-only register; always reads as 0	1
Block Size:							100
<b>End of Map</b>							

SINT32 / UINT32 32-bit signed / unsigned integer spanning 2 registers. The lower-addressed register is the high order half  
 FLOAT 32-bit IEEE floating point number spanning 2 registers. The lower-addressed register is the high order half (i.e., contains the exponent)

- 1 All registers not explicitly listed in the table read as 0. Writes to these registers will be accepted but won't actually change the register (since it doesn't exist).
- 2 Meter Data Section items read as 0 until first readings are available or if the meter is not in operating mode. Writes to these registers will be accepted but won't actually change the register.
- 3 Register valid only in programmable settings update mode. In other modes these registers read as 0 and return an illegal data address exception if a write is attempted.
- 4 Meter command registers always read as 0. They may be written only when the meter is in a suitable mode. The registers return an illegal data address exception if a write is attempted in an incorrect mode.
- 5 If the password is incorrect, a valid response is returned but the command is not executed. Use 5555 for the password if passwords are disabled in the programmable settings.
- 6 M denotes a 1,000,000 multiplier.
- 7 Not applicable to Shark 100, V-Switch 1, 2, or 3
- 8 Writing this register causes data to be saved permanently in EEPROM. If there is an error while saving, a slave device failure exception is returned and programmable settings mode automatically terminates via reset.
- 9 Reset commands make no sense if the meter state is LIMP. An illegal function exception will be returned.
- 10 Energy registers should be reset after a format change.
- 11 Entities to be monitored against limits are identified by Modbus address. Entities occupying multiple Modbus registers, such as floating point values, are identified by the lower register address. If any of the 8 limits is unused, set its identifier to zero. If the indicated Modbus register is not used or is a non-sensical entity for limits, it will behave as an unused limit.
- 12 There are 2 setpoints per limit, one above and one below the expected range of values. LM1 is the "too high" limit, LM2 is "too low". The entity goes "out of limit" on LM1 when its value is greater than the setpoint. It remains "out of limit" until the value drops below the in threshold. LM2 works similarly, in the opposite direction. If limits in only one direction are of interest, set the in threshold on the "wrong" side of the setpoint. Limits are specified as % of full scale, where full scale is automatically set appropriately for the entity being monitored:
  - current FS = CT numerator \* CT multiplier
  - voltage FS = PT numerator \* PT multiplier
  - power FS = CT numerator \* CT multiplier \* PT numerator \* PT multiplier \* 3 [ \* SQRT(3) for delta hookup]
  - frequency FS = 60 (or 50)
  - power factor FS = 1.0
  - percentage FS = 100.0
  - angle FS = 180.0
- 13 THD not available shows 65535 (=0xFFFF) in all THD and harmonic magnitude registers for the channel when V-switch=4. THD may be unavailable due to low V or I amplitude, or delta hookup (V only).
- 14 All 3 voltage angles are measured for Wye and Delta hookups. For 2.5 Element, Vac is measured and Vab & Vbc are calculated. If a voltage phase is missing, the two voltage angles in which it participates are set to zero. A and C phase current angles are measured for all hookups. B phase current angle is measured for Wye and is zero for other hookups. If a voltage phase is missing, its current angle is zero.

## C: Shark® 100S Meter DNP Map

### C.1: Introduction

The Shark® 100S meter's DNP map shows the client-server relationship in the meter's use of DNP Protocol.

### C.2: DNP Mapping (DNP-1 to DNP-2)

The Shark® 100S DNP Point Map follows.

Binary Output States, Control Relay Outputs, Binary Counters (Primary) and Analog Inputs are described on page DNP-1.

Internal Indication is described on page DNP-2.

Object	Point	Var	Description	Format	Range	Multiplier	Units	Comments
<b>Binary Output States</b> <span style="float: right;">Read via Class 0 only</span>								
10	0	2	Reset Energy Counters	BYTE	Always 1	N/A	none	
10	1	2	Change to Modbus RTU Protocol	BYTE	Always 1	N/A	none	
<b>Control Relay Outputs</b>								
12	0	1	Reset Energy Counters	N/A	N/A	N/A	none	Responds to Function 5 (Direct Operate), Qualifier Code 17x or 28x, Control Code 3, Count 0, On 0 msec, Off 1 msec ONLY.
12	1	1	Change to Modbus RTU Protocol	N/A	N/A	N/A	none	Responds to Function 6 (Direct Operate - No Ack), Qualifier Code 17x, Control Code 3, Count 0, On 0 msec, Off 1 msec ONLY.
<b>Binary Counters (Primary)</b> <span style="float: right;">Read via Class 0 only</span>								
20	0	4	W-hours, Positive	UINT32	0 to 99999999	multiplier = $10^{(n-d)}$ , where n and d are derived from the energy format. n = 0, 3, or 6 per energy format scale and d = number of decimal places.	W hr	example: energy format = 7.2K and W-hours counter = 1234567 n=3 (K scale), d=2 ( 2 digits after decimal point), multiplier = $10^{(3-2)} = 10^1 = 10$ , so energy is 1234567 * 10 Whrs, or 12345.67 KWhrs
20	1	4	W-hours, Negative	UINT32	0 to 99999999		W hr	
20	2	4	VAR-hours, Positive	UINT32	0 to 99999999		VAR hr	
20	3	4	VAR-hours, Negative	UINT32	0 to 99999999		VAR hr	
20	4	4	VA-hours, Total	UINT32	0 to 99999999		VA hr	
<b>Analog Inputs (Secondary)</b> <span style="float: right;">Read via Class 0 only</span>								
30	0	5	Meter Health	SINT16	0 or 1	N/A	none	0 = OK
30	1	5	Volts A-N	SINT16	0 to 32767	(150 / 32768)	V	Values above 150V secondary read 32767.
30	2	5	Volts B-N	SINT16	0 to 32767	(150 / 32768)	V	
30	3	5	Volts C-N	SINT16	0 to 32767	(150 / 32768)	V	
30	4	5	Volts A-B	SINT16	0 to 32767	(300 / 32768)	V	
30	5	5	Volts B-C	SINT16	0 to 32767	(300 / 32768)	V	Values above 300V secondary read 32767.
30	6	5	Volts C-A	SINT16	0 to 32767	(300 / 32768)	V	
30	7	5	Amps A	SINT16	0 to 32767	(10 / 32768)	A	Values above 10A secondary read 32767.
30	8	5	Amps B	SINT16	0 to 32767	(10 / 32768)	A	
30	9	5	Amps C	SINT16	0 to 32767	(10 / 32768)	A	

Object	Point	Var	Description	Format	Range	Multiplier	Units	Comments
30	10	5	Watts, 3-Ph total	SINT16	-32768 to +32767	(4500 / 32768)	W	
30	11	5	VARs, 3-Ph total	SINT16	-32768 to +32767	(4500 / 32768)	VAR	
30	12	5	VAs, 3-Ph total	SINT16	0 to +32767	(4500 / 32768)	VA	
30	13	5	Power Factor, 3-Ph total	SINT16	-1000 to +1000	0.001	none	
30	14	5	Frequency	SINT16	0 to 9999	0.01	Hz	
30	15	5	Positive Watts, 3-Ph, Maximum Avg Demand	SINT16	-32768 to +32767	(4500 / 32768)	W	
30	16	5	Positive VARs, 3-Ph, Maximum Avg Demand	SINT16	-32768 to +32767	(4500 / 32768)	VAR	
30	17	5	Negative Watts, 3-Ph, Maximum Avg Demand	SINT16	-32768 to +32767	(4500 / 32768)	W	
30	18	5	Negative VARs, 3-Ph, Maximum Avg Demand	SINT16	-32768 to +32767	(4500 / 32768)	VAR	
30	19	5	VAs, 3-Ph, Maximum Avg Demand	SINT16	-32768 to +32767	(4500 / 32768)	VA	
30	20	5	Angle, Phase A Current	SINT16	-1800 to +1800	0.1	degree	
30	21	5	Angle, Phase B Current	SINT16	-1800 to +1800	0.1	degree	
30	22	5	Angle, Phase C Current	SINT16	-1800 to +1800	0.1	degree	
30	23	5	Angle, Volts A-B	SINT16	-1800 to +1800	0.1	degree	
30	24	5	Angle, Volts B-C	SINT16	-1800 to +1800	0.1	degree	
30	25	5	Angle, Volts C-A	SINT16	-1800 to +1800	0.1	degree	
30	26	5	CT numerator	SINT16	1 to 9999	N/A	none	CT ratio = (numerator * multiplier) / denominator
30	27	5	CT multiplier	SINT16	1, 10, or 100	N/A	none	
30	28	5	CT denominator	SINT16	1 or 5	N/A	none	
30	29	5	PT numerator	SINT16	1 to 9999	N/A	none	PT ratio = (numerator * multiplier) / denominator
30	30	5	PT multiplier	SINT16	1, 10, or 100	N/A	none	
30	31	5	PT denominator	SINT16	1 to 9999	N/A	none	
30	32	5	Neutral Current	SINT16	0 to 32767	(10 / 32768)	A	For 1A model, multiplier is (2 / 32768) and values above 2A secondary read 32767.
<b>Internal Indication</b>								
80	0	1	Device Restart Bit	N/A	N/A	N/A	none	Clear via Function 2 (Write), Qualifier Code 0.



# D: DNP 3.0 Protocol Assignments

## D.1: DNP Implementation

### PHYSICAL LAYER

The Shark® 100S meter can use RS485 as the physical layer. This is accomplished by connecting a PC to the meter using the meter's RS485 connection (see Chapter 5).

### RS485

RS485 provides multi-drop network communication capabilities. Multiple meters can be placed on the same bus, allowing for a Master device to communicate with any of the other devices. Appropriate network configuration and termination should be evaluated for each installation to insure optimal performance (see Chapter 5).

### Communication Parameters

Shark® 100S meters communicate in DNP 3.0 using the following communication settings:

- 8 Data Bits
- No Parity
- 1 Stop Bit
- Baud Rates: 9600, 19200, 38400, 57600

## D.2: Data Link Layer

The Data Link Layer for Shark® 100S meters is subject to the following considerations:

### **Control Field**

The Control Byte contains several bits and a Function Code.

#### Control Bits

Communication directed to the meter should be Primary Master messages (DIR = 1, PRM = 1). Response will be primary Non-Master messages (DIR = 0, PRM = 1). Acknowledgment will be Secondary Non-Master messages (DIR = 0, PRM = 0).

### **Function Codes**

Shark® 100S meters support all of the Function Codes for DNP 3.0.

#### Reset of Data Link (Function 0)

Before confirmed communication with a master device, the Data Link Layer must be reset. This is necessary after a meter has been restarted, either by applying power to the meter or reprogramming the meter. The meter must receive a RESET command before confirmed communication can take place. Unconfirmed communication is always possible and does not require a RESET.

#### User Data (Function 3)

After receiving a request for USER DATA, the meter generates a Data Link CONFIRMATION, signaling the reception of the request, before the actual request is processed. If a response is required, it is also sent as UNCONFIRMED USER DATA.

#### Unconfirmed User Data (Function 4)

After receiving a request for UNCONFIRMED USER DATA, if a response is required, it is sent as UNCONFIRMED USER DATA.

#### Address

DNP 3.0 allows for addresses from 0 - 65534 (0x0000 - 0xFFFFE) for individual device identification, with the address 65535 (0xFFFF) defined as an all stations address.

Shark® 100S meters' addresses are programmable from 0 - 247 (0x0000 - 0x00F7), and address 65535 (0xFFFF) is recognized as the all stations address.

### D.3: Transport Layer

The Transport Layer as implemented on Shark® 100S meters is subject to the following considerations:

#### Transport Header

Multiple-frame messages are not allowed for Shark® 100S meters. Each Transport Header should indicate it is both the first frame (FIR = 1) as well as the final frame (FIN = 1).

### D.4: Application Layer

The Application Layer contains a header (Request or Response Header, depending on direction) and data.

#### **Application Headers**

Application Headers contain the Application Control Field and the Function Code.

#### **Application Control Field**

Multiple-fragment messages are not allowed for Shark® 100S meters. Each Application Header should indicate it is both the first fragment (FIR = 1) as well as the final fragment (FIN = 1). Application-Level confirmation is not used by Shark® 100S meters.

#### **Function Codes**

The following Function codes are implemented on Shark® 100S meters.

#### Read (Function 1)

Objects supporting the READ function are:

- Binary Outputs (Object 10)
- Counters (Object 20)
- Analog Inputs (Object 30)

- Class (Object 60)

These Objects can be read either by requesting a specific Variation available as listed in this appendix, or by requesting Variation 0. READ requests for Variation 0 of an Object is fulfilled with the Variation listed in this appendix.

#### Write (Function 2)

Objects supporting the WRITE function are:

- Internal Indications (Object 80)

#### Direct Operate (Function 5)

Objects supporting the DIRECT OPERATE function are:

- Control Relay Output Block (Object 12)

#### Direct Operate - No Acknowledgment (Function 6)

Objects supporting the DIRECT OPERATE - NO ACKNOWLEDGMENT function are:

- Change to MODBUS RTU Protocol

#### Response (Function 129)

Application responses from Shark® 100 meters use the RESPONSE function.

### **Application Data**

Application Data contains information about the Object and Variation, as well as the Qualifier and Range.

#### **D.4.1: Object and Variation**

The following Objects (Obj.) and Variations (Var.) are supported by Shark® 100S meters:

- Binary Output Status (Object 10, Variation 2) †
- Control Relay Output Block (Object 12, Variation 1)
- 32-Bit Binary Counter Without Flag (Object 20, Variation 5) †

- 16-Bit Analog Input Without Flag (Object 30, Variation 4) †
- Class 0 Data (Object 60, Variation 1) †
- Internal Indications (Object 80, Variation 1)

† READ requests for Variation 0 are honored with the above Variations.

#### **D.4.1.1: Binary Output Status (Obj. 10, Var. 2)**

Binary Output Status supports the following function:

##### **Read (Function 1)**

A READ request for Variation 0 is responded to with Variation 2.

Binary Output Status is used to communicate the following data measured by Shark® 100S meters:

##### **Energy Reset State**

Change to MODBUS RTU Protocol State

##### Energy Reset State (Point 0)

Shark® 100S meters accumulate power generated or consumed over time as Hour Readings, which measure positive VA Hours and positive and negative W Hours and VAR Hours. These readings can be reset using a Control Relay Output Block object (Object 12). The Binary Output Status point reports whether the Energy Readings are in the process of being reset, or are accumulating. Normally, readings are being accumulated - the state of this point reads as '0'. If readings are in the process of being reset, the state of this point reads as '1'.

##### Change to Modbus RTU Protocol State (Point 1)

Shark® 100S meters can of change from DNP Protocol to Modbus RTU Protocol. This enables the user to update the Device Profile of the meter (this does not change the meter's Protocol setting). A meter reset brings communication back to DNP. A status reading of "1" equals Open, or de-energized. A reading of "0" equals Closed, or energized.

### **D.4.1.2: Control Relay Output Block (Obj. 12, Var. 1)**

Control Relay Output Block supports the following functions:

#### **Direct Operate (Function 5)**

#### **Direct Operate - No Acknowledgment (Function 6)**

Control Relay Output Blocks are used for the following purposes:

#### **Energy Reset**

Change to MODBUS RTU Protocol

#### Energy Reset (Point 0)

As stated previously, Shark® 100S meters accumulate power generated or consumed over time as Hour Readings, which measure positive VA Hours and positive and negative W Hours and VAR Hours. These readings may be reset using Point 0.

#### Change to Modbus RTU Protocol (Point 1)

Refer to Section D.4.1.1 on the previous page for the Change to Modbus Protocol information.

Use of the DIRECT OPERATE (Function 5) function will operate only with the settings of Pulsed ON (Code = 1 of Control Code Field) once (Count = 0x01) for ON 1 millisecond and OFF 0 milliseconds.

### D.4.1.3: 32-Bit Binary Counter Without Flag (Obj. 20, Var. 5)

Counters support the following functions:

#### Read (Function 1)

A READ request for Variation 0 is responded to with Variation 5.

Counters are used to communicate the following data measured by Shark® 100S meters:

#### Hour Readings

Hour Readings (Points 0 - 4)

Point	Readings	Unit
0	+W hour	Wh
1	-W hour	Wh
2	+VAR hour	VARh
3	-VAR hour	VARh
4	+VA hour	VAh

**NOTE:** These readings may be cleared by using the Control Relay Output Block (see previous Section D.4.1.2).

### D.4.1.4: 16-Bit Analog Input Without Flag (Obj. 30, Var. 4)

Analog Inputs support the following functions:

#### Read (Function 1)

A READ request for Variation 0 is responded to with Variation 4.

Analog Inputs are used to communicate the following data measured by Shark® 100S meters:

- Health Check
- Phase-to-Neutral Voltage
- Phase-to-Phase Voltage

- Phase Current
- Total Power
- Three Phase Total VAs
- Three Phase Power Factor Total
- Frequency
- Three Phase +Watts Max Avg Demand
- Three Phase + VARs Max Avg Demand
- Three Phase -Watts Max Avg Demand
- Three Phase -VARs Max Avg Demand
- Three Phase VAs Max Avg Demand
- Angle, Phase Power
- Angle, Phase-to-Phase Voltage
- CT Numerator, Multiplier, Denominator
- PT Numerator, Multiplier, Denominator

#### Health Check (Point 0)

The Health Check point is used to indicate problems detected by the Shark® 100S meter. A value of zero (0x0000) indicates the meter does not detect a problem. Non-zero values indicate a detected anomaly.



Phase-to-Neutral Voltage (Points 1 - 3)

Point	Reading
1	Phase AN Voltage
2	Phase BN Voltage
3	Phase CN Voltage

These points are formatted as 2's complement fractions. They represent a fraction of a 150V Secondary input. Inputs of above 150V Secondary are pinned at 150V Secondary.

Phase-to-Phase Voltage (Points 4 - 6)

Point	Reading
4	Phase AB Voltage
5	Phase BC Voltage
6	Phase CA Voltage

These points are formatted as 2's complement fractions. They represent a fraction of a 300V Secondary input. Inputs of above 30 V Secondary are pinned at 300V Secondary.

Phase Current (Points 7 - 9)

Point	Reading
7	Phase A Current
8	Phase B Current
9	Phase C Current

These points are formatted as 2's complement fractions. They represent a fraction of a 10A Secondary input. Inputs of above 10A Secondary are pinned at 10A Secondary.

Total Power (Points 10 - 11)

Point	Reading
10	Total Watt
11	Total VAR

These points are formatted as 2's complement fractions. They represent a fraction of 4500W Secondary in normal operation, or 3000W Secondary in Open Delta operation. Inputs above/below +/-4500 or +/-3000W Secondary are pinned at +/-4500 or +/-3000W Secondary, respectively.

Total VA (Point 12)

Point	Reading
12	Total VA

This point is formatted as a 2's complement fraction. It represents a fraction of 4500W Secondary in normal operation, or 3000W Secondary in Open Delta operation. Inputs above/below +/-4500 or +/-3000W Secondary are pinned at +/-4500 or +/-3000W Secondary, respectively.

Power Factor (Point 13)

Point	Reading
13	Power Factor Total

This point is formatted as a 2's complement integer. It represents Power Factors from -1.000 (0x0FC18) to +1.000 (0x003E8). In Open Delta operation, Total Power Factor (Point 13) is always zero.

Frequency (Point 14)

Point	Reading
14	Frequency

This point is formatted as a 2's complement fraction. It represents the Frequency as measured on Phase A Voltage in units of cHz (centiHertz, 1/100 Hz). Inputs below 45.00 Hz are pinned at 0 (0x0000); inputs above 75.00 Hz are pinned at 9999 (0x270F).

Maximum Demands of Total Power (Points 15 - 19)

Point	Reading
15	Maximum Positive Demand Total Watts
16	Maximum Positive Demand Total VARs
17	Maximum Negative Demand Total Watts
18	Maximum Negative Demand Total VARs
19	Maximum Average Demand VAs

These points are formatted as 2's complement fractions. They represent a fraction of 4500W Secondary in normal operation, or 3000W Secondary in Open Delta operation. Inputs above/below +/-4500 or +/-3000W Secondary are pinned at +/-4500 or +/-3000W Secondary, respectively.

Phase Angle (Points 20 - 25)

Point	Reading
20	Phase A Current Angle
21	Phase B Current Angle
22	Phase C Current Angle
23	Volts A-B Angle
24	Volts B-C Angle
25	Volts C-A Angle

These points are formatted as 2's complement integers. They represent angles from -180.00 (0x0F8F8) to +180.00 (0x00708).

CT & PT Ratios (Points 26 - 31)

Point	Reading
26	CT Ratio Numerator
27	CT Ratio Multiplier
28	CT Ratio Denominator
29	PT Ratio Numerator
30	PT Ratio Multiplier
31	PT Ratio Denominator

These points are formatted as 2's complement integers. They can be used to convert from units in terms of the Secondary of a CT or PT into units in terms of the Primary of a CT or PT. The ratio of Numerator divided by Denominator is the ratio of Primary to Secondary.

Shark® 100 meters typically use Full Scales relating Primary Current to 5A and Primary Voltage to 120V. However, these Full scales can range from mAs to thousands of kAs, and from mVs, to thousands of kVs. Following are example settings:

### **CT Example Settings**

200 Amps: Set the Ct-n value for 200 and the Ct-S value for 1.

800 Amps: Set the Ct-n value for 800 and the Ct-S value for 1.

2,000 Amps: Set the Ct-n value for 2000 and the Ct-S value for 1.

10,000 Amps: Set the Ct-n value for 1000 and the Ct-S value for 10.

**NOTE:** CT Denominator is fixed at 5 for 5A units; CT Denominator is fixed at 1 for 1A units.

### **PT Example Settings**

277 Volts (Reads 277 Volts): Pt-n value is 277, Pt-d value is 277, Pt-S value is 1.

120 Volts (Reads 14,400 Volts): Pt-n value is 1440, Pt-d value is 120, Pt-S value is 10.

69 Volts (Reads 138,000 Volts): Pt-n value is 1380, Pt-d value is 69, Pt-S value is 100.

115 Volts (Reads 347,000 Volts): Pt-n value is 3470, Pt-d value is 115, Pt-S value is 100.

69 Volts (Reads 347,000 Volts): Pt-n value is 347, Pt-d value is 69, Pt-S value is 1000.

#### **D.4.1.5: Class 0 Data (Obj. 60, Var. 1)**

Class 0 Data supports the following functions:

##### **Read (Function 1)**

A request for Class 0 Data from a Shark® 100S meter returns three Object Headers. Specifically, it returns 16-Bit Analog Input Without Flags (Object 30, Variation 4), Points 0 - 31, followed by 32-Bit Counters Without Flags (Object 20, Variation 5), Points 0 - 4, followed by Binary Output Status (Object 10, Variation 2), Points 0 - 1. (There is NO Object 1.)

A request for Object 60, Variation 0 is treated as a request for Class 0 Data.

#### **D.4.1.6: Internal Indications (Obj. 80, Var. 1)**

Internal Indications support the following functions:

##### **Write (Function 2)**

Internal Indications may be indexed by Qualifier Code 0.

##### **Device Restart (Point 0)**

This bit is set whenever the meter resets. The polling device may clear this bit by Writing (Function 2) to Object 80, Point 0.

# E: Using the USB to IrDA Adapter CAB6490

## E.1: Introduction

Com 1 of the Shark® 100S meter is the IrDA port, located on the face of the meter. One way to communicate with the IrDA port is with EIG's USB to IrDA Adapter CAB6490, which allows you to access the Shark® meter's data from a PC. This Appendix contains instructions for installing the USB to IrDA Adapter.

## E.2: Installation Procedures

You can order CAB6490 from [EIG's website](#). Select Cables and Accessories from the list on the left side of the screen. The USB to IrDA Adapter comes packaged with a USB cable and an Installation CD. Follow this procedure to install the Adapter on your PC.

1. Connect the USB cable to the USB to IrDA Adapter, and plug the USB into your PC's USB port.
2. Insert the Installation CD into your PC's CD ROM drive.
3. You will see the screen shown below. The Found New Hardware Wizard allows you to install the software for the Adapter. Click the Radio Button next to **Install from a list or specific location**.

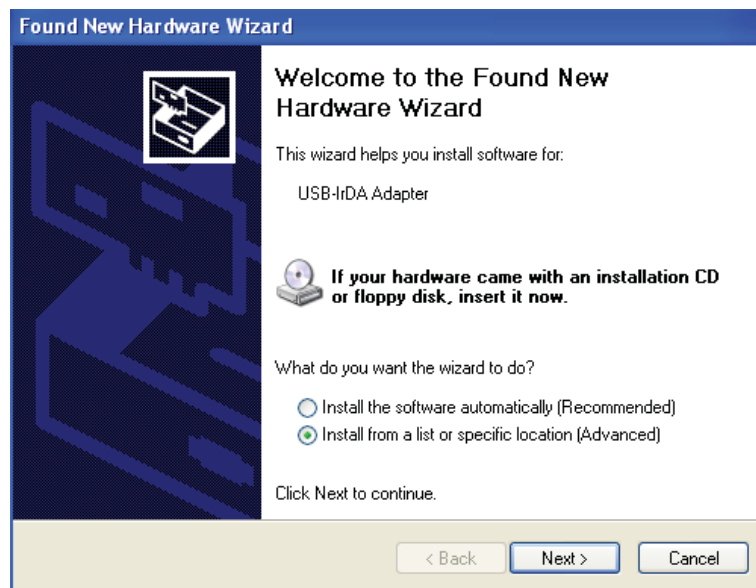

4. Click **Next**. You will see the screen shown on the next page.

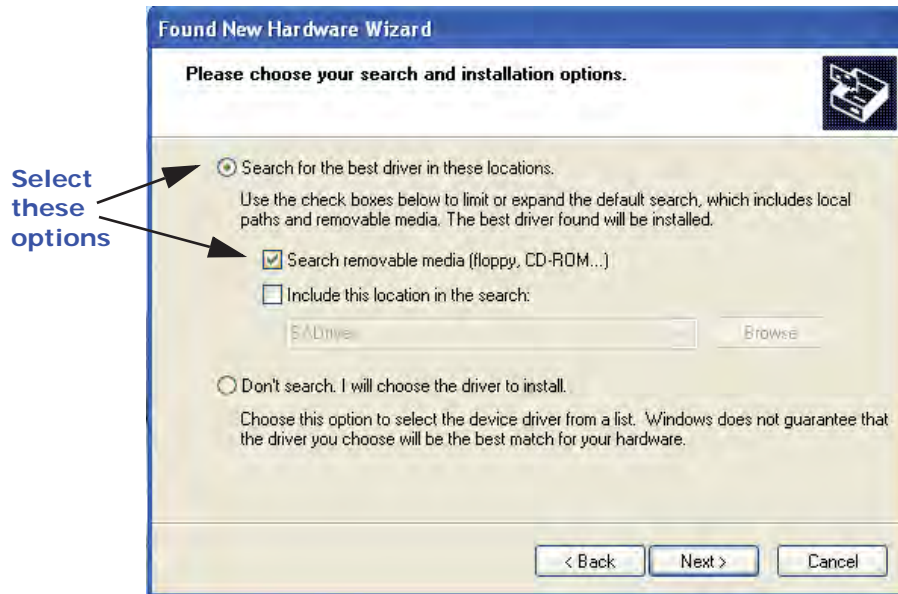

5. Make sure the first Radio Button and the first Checkbox are selected, as shown above. These selections allow the Adapter's driver to be copied from the Installation disk to your PC.

6. Click **Next**. You will see the screen shown below.



7. When the driver for the Adapter is found, you will see the screen shown on the next page.

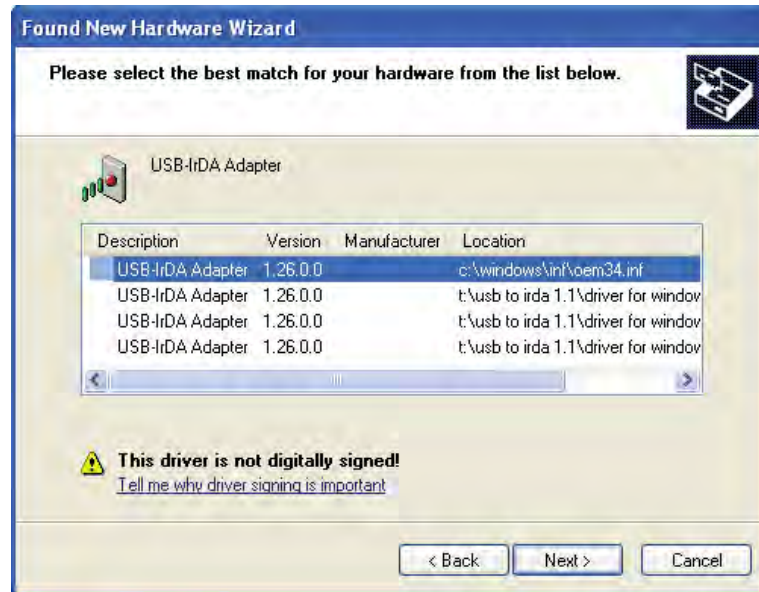

8. You do not need to be concerned about the message on the bottom of the screen. Click **Next** to continue with the installation.

9. You will see the two windows shown below. Click **Continue Anyway**.





10. You will see the screen shown below while the Adapter's driver is being installed on your PC.



11. When driver installation is complete, you will see the screen shown below.



12. Click **Finish** to close the Found New Hardware Wizard.

**IMPORTANT! Do NOT remove the Installation CD until the entire procedure has been completed.**

13. Position the USB to IrDA Adapter so that it points directly at the IrDA on the front of the Shark® 100S meter. It should be as close as possible to the meter, and not more than 15 inches/38 cm away from it.

14. The Found New Hardware Wizard screen opens again. This time, click the Radio Button next to Install the software automatically.

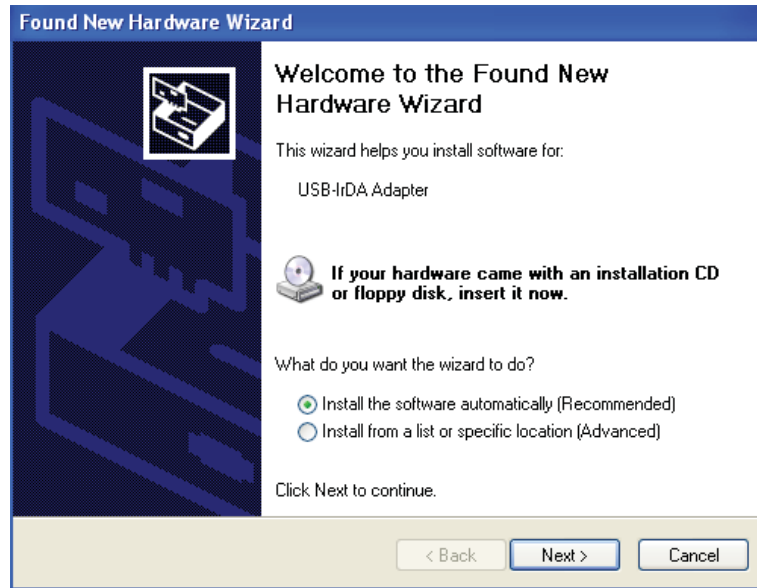

15. Click **Next**. You will see the screen shown below.

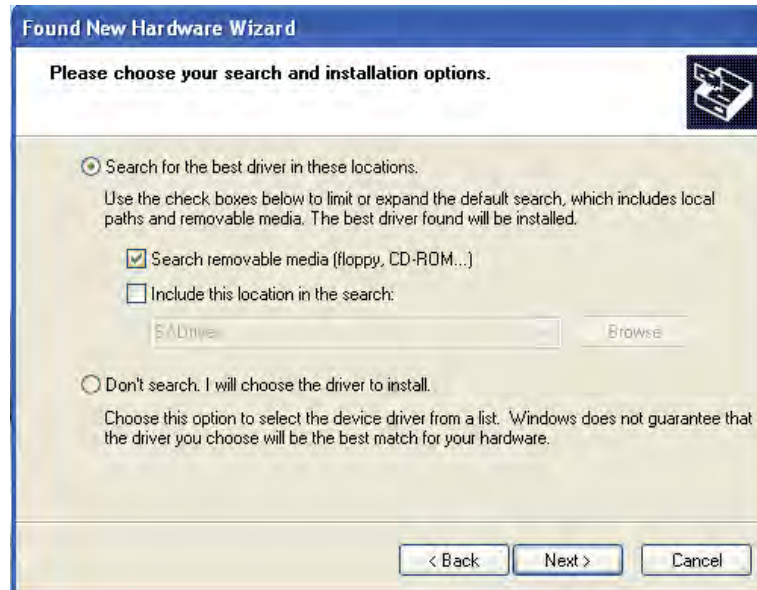

16. Make sure the first Radio Button and the first Checkbox are selected, as shown above screen. Click **Next**. You will see the two screens shown on the next page.



17. When installation is complete, you will see the screen shown below.

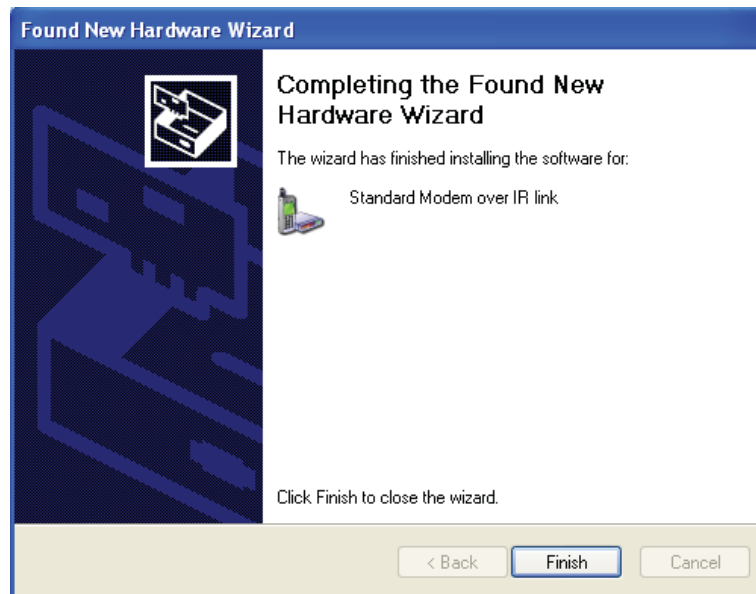

18. Click **Finish** to close the Found New Hardware Wizard.

19. To verify that your Adapter has been installed properly, click **Start>Settings>Control Panel>System>Hardware>Device Manager**. The USB to IrDA Adapter should appear under both Infrared Devices and Modems (click on the + sign to display all configured modems). See the example screen on the next page.

**NOTE:** If the Adapter doesn't show up under Modems, move it away from the meter for a minute and then position it pointing at the IrDA, again.

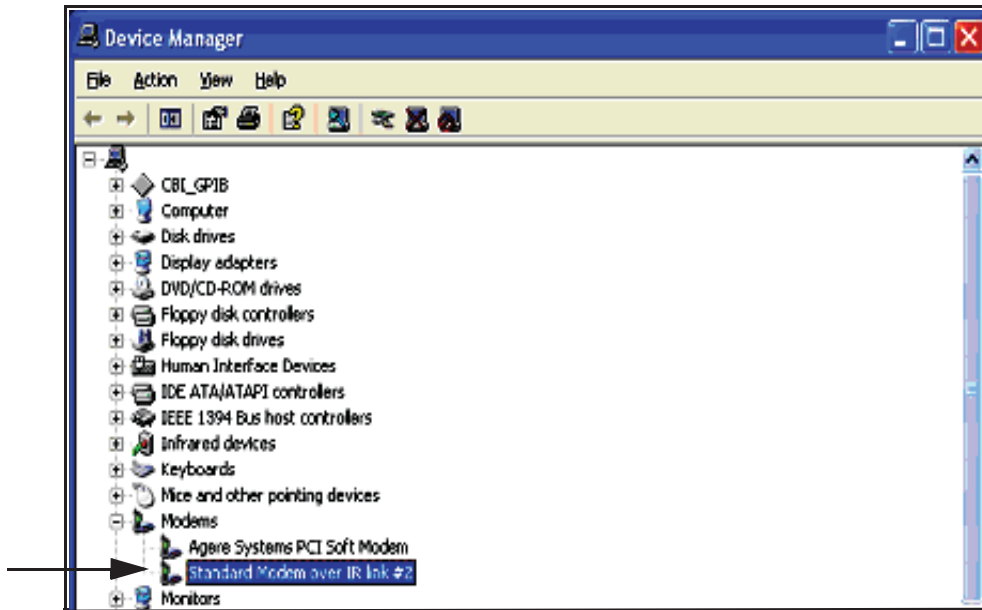

20. Double-click on the Standard Modem over IR link (this is the USB to IrDA Adapter). You will see the Properties screen for the Adapter.

21. Click the Modem tab. The Com Port that the Adapter is using is displayed in the screen.

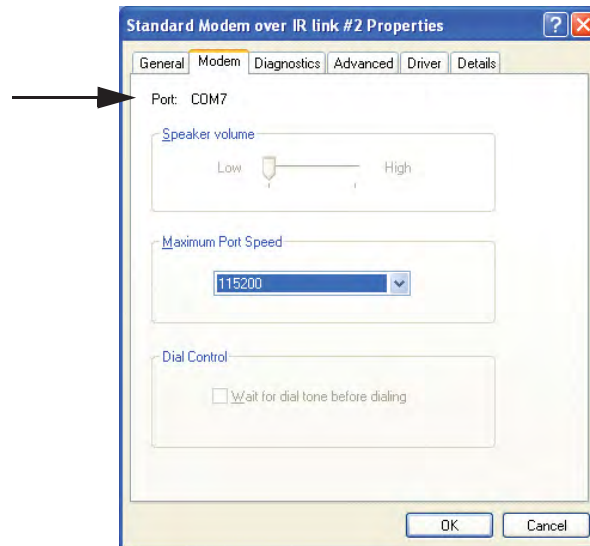

22. Use this Com Port to connect to the meter from your PC, using the Communicator EXT software. Refer to Chapter 3 of the *Communicator EXT™ 4.0 and MeterManager EXT Software User Manual* for detailed connection instructions.